



Designation: D5494 – 93 (Reapproved 2006)

Standard Test Method for the Determination of Pyramid Puncture Resistance of Unprotected and Protected Geomembranes¹

This standard is issued under the fixed designation D5494; the number immediately following the designation indicates the year of original adoption or, in the case of revision, the year of last revision. A number in parentheses indicates the year of last reapproval. A superscript epsilon (ϵ) indicates an editorial change since the last revision or reapproval.

1. Scope

1.1 The test method is to be used as an index test to determine the pyramid puncture resistance of geomembranes and, or both, geomembranes protected by non-woven geotextiles and other puncture protective geosynthetics.

1.2 The test method measures the increase of the pyramid puncture resistance due to the use of protective non-woven geotextiles with geomembranes.

1.3 The values stated in SI units are to be regarded as the standard value. The values stated in parentheses are provided for information only.

1.4 *This standard does not purport to address all of the safety problems, if any, associated with its use. It is the responsibility of the user of this standard to establish appropriate safety and health practices and determine the applicability of regulatory limitations prior to use.*

2. Referenced Documents

2.1 *ASTM Standards:*²

D76 Specification for Tensile Testing Machines for Textiles

D4354 Practice for Sampling of Geosynthetics for Testing

D4439 Terminology for Geosynthetics

D4491 Test Methods for Water Permeability of Geotextiles by Permittivity

3. Terminology

3.1 *Definitions:*

3.1.1 *atmosphere for testing geosynthetics, n*—air maintained at a relative humidity between 50 to 70 % and a temperature of $21 \pm 2^\circ\text{C}$ ($70 \pm 4^\circ\text{F}$).

3.1.2 *geomembrane, n*—an essentially impermeable geosynthetic composed of one or more synthetic sheets.

3.1.2.1 *Discussion*—In geotechnical engineering, essentially impermeable means that no measurable liquid flows through a geosynthetic when tested in accordance with Test Method D4491.

3.1.3 *geotextile, n*—a permeable geosynthetic comprised solely of textiles.

3.1.3.1 *Discussion*—Current manufacturing techniques produce non-woven fabrics, knitted (non-tubular) fabrics, and woven fabrics.

3.1.4 For other terms, see Terminology D4439.

4. Summary of Test Method

4.1 A test specimen is clamped without tension between circular plates of a ring clamp attachment secured in a compression press or tensile testing machine. A force is exerted against the center of the unsupported or supported portion of the test specimen by a solid steel pyramid attached to a load indicator until rupture of the specimen occurs. The maximum load and elongation recorded is the value of the puncture resistance of the specimen.

5. Significance and Use

5.1 The pyramid method of puncture resistance is an index test for the determination of the puncture resistance of unprotected geomembranes or geomembranes protected with non-woven geotextiles and other puncture protective geosynthetics.

5.1.1 The purpose of this test method is to establish an index value of puncture resistance by providing standard criteria and a basis for uniform reporting.

5.2 This test method may be used for acceptance testing of commercial shipments of geomembranes and geomembranes protected with non-woven geotextiles; however, caution is advised since information about between laboratory precision is incomplete.

6. Apparatus

6.1 *Test Set Up*—A compression press with a reading force accuracy of at least 2 N (0.5 lb) is necessary. The press must maintain a constant test speed and should be provided with an automatic chart recorder for the force vs. deformation behavior. A clamping device for the test sample, a special piston and electrical signal equipment for determining the puncture load

¹ This test method is under the jurisdiction of ASTM Committee D35 on Geosynthetics and is the direct responsibility of D35.10 on Geomembranes.

Current edition approved July 1, 2006. Published September 2006. Originally approved in 1993. Last previous edition approved in 1999 as D5494-93(1999)¹. DOI: 10.1520/D5494-93R06.

² For referenced ASTM standards, visit the ASTM website, www.astm.org, or contact ASTM Customer Service at service@astm.org. For *Annual Book of ASTM Standards* volume information, refer to the standard's Document Summary page on the ASTM website.

are the additional pieces of test equipment needed. Also, a tensile testing machine conforming to the requirements of Specification D76 can be utilized in a compression mode for this test method. The equipment set up shall provide a constant rate of speed, reading accuracy of at least 2 N (0.5 lb) and be provided with an automatic chart recorder for load vs. deformation. Additional equipment required by this test method is described below.

6.2 *Clamping Device*—The upper and lower fixing ring clamp, dimensions of which are shown on Fig. 1 a and 1b. The lower fixing ring shall be provided with a circular recess with a diameter corresponding to the external diameter of the compression base. This will facilitate mounting of the lower fixing ring to the compression base as illustrated on Fig. 2. Concentrically arranged grooves shall be located on the lower face of the upper ring and upper face of the lower ring to facilitate non-slip clamping of the test specimen(s).

6.3 *Compression Base* (Fig. 2)—CBR type test presses are normally equipped with a CBR-cylinder compression base having a diameter of 150 mm (6.0 in.) as shown on Fig. 2. Additionally, the compression base must be deep enough to allow the loading piston to plunge at least 100 mm (4.0 in.). The compression base should be manufactured of rust resistant high-grade steel.

6.4 *Underlying Test Media*—Either water or an aluminum plate can be used as the underlying medium for this test method. The water (which serves as an electrical conductor) simulates a non-rigid underlying medium and the aluminum simulates a hard, rigid medium. The aluminum plate (Fig. 3) must be placed on the compression base so that the sealing system (geomembrane and geotextile) lies flat on it. The aluminum plate shall be reinforced (possibly with a steel plate) to prevent bending (Fig. 3).

6.5 *Loading Piston* (Fig. 4)—The loading piston shall be a cylinder with a diameter of 25 mm ± 0.1 mm (1 in. ± 0.004 in.) with a polished and hardened pyramid formed apex as shown on Fig. 4. The apex shall be a four sided pyramid with an apex angle of 90° rounded off with a radius (R) of 0.5 mm ± 0.01 mm (0.02 in. ± 0.0004 in.). The edges of the pyramid

shall be rounded off with a radius of 0.1 mm ± 0.01 mm (0.004 in. ± 0.0004 in.). The transitional edge from the base of the pyramid to the cylinder shall have a radius (R) of 3.0 mm ± 0.1 mm (0.12 in. ± 0.004 in.).

6.6 *Electrical Equipment for the Determination of the Puncture Load*—An electrical circuit is to be employed between the loading piston and the underlying medium (water or aluminum plate) such that puncture resistance load at failure can be determined. The electrical circuit, which is closed at the moment of puncture, can be connected to a signal lamp and the puncture resistance load can be recorded at failure.

7. Sampling

7.1 *Lot Sample*—Divide the product into lots and take the lot sample as directed in Practice D4354.

7.2 *Laboratory Sample*—For the laboratory sample take a swatch extending the full width of the geosynthetic, of sufficient length from each sample roll so that the requirements of Sections 7.3 and 9 can be met. Take a sample that will exclude material from the outer wrap and inner wrap around the core unless the sample is taken at the production site, in which case inner and outer wrap material may be used.

7.3 Test for underlying water medium: The test specimen shall be cut out with a punch with a diameter greater than 80 mm or cut out with a large pair of shears.

7.3.1 The sample is fixed between the ring clamps (Fig. 1 and Fig. 2) so that no slippage occurs.

7.3.2 For underlying aluminum plate medium: Test sample fixing with clamps is not required; deformation of the sample is not induced during testing. With this test condition any reasonable sample size with a diameter >50 mm (>2 in.) can be tested.

8. Procedure

8.1 Test the conditioned specimens in the standard atmosphere for testing as defined in 3.1.

8.1.1 Select the load range of the tensile/compression testing machine such that the ruptures occur between 10 and 90 % of the full-scale load.

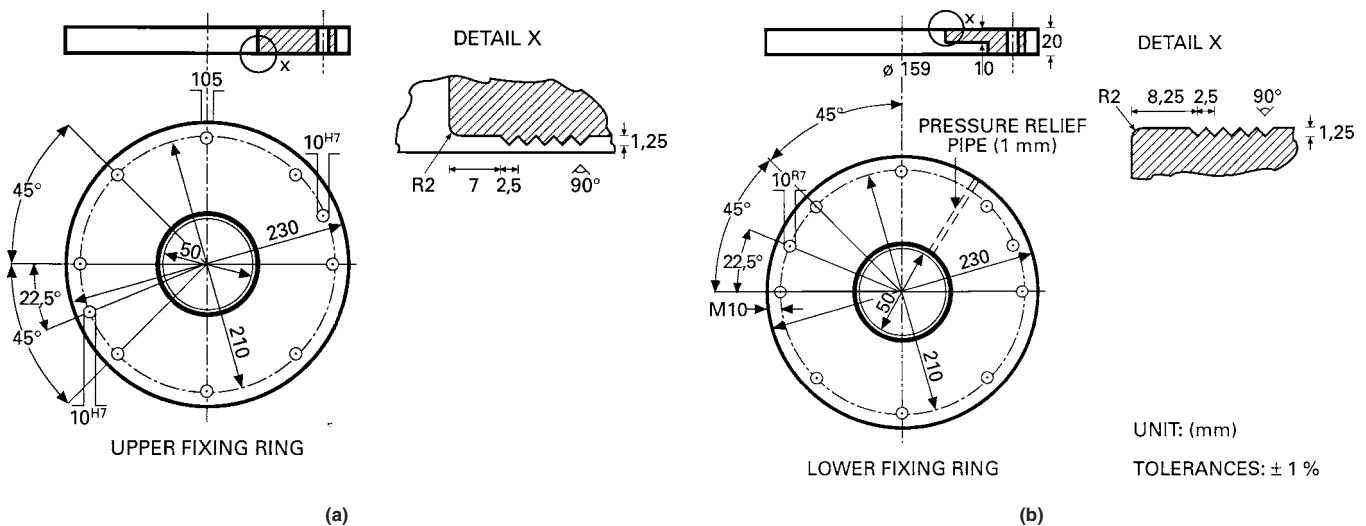

FIG. 1 Upper and Lower Fixing Ring (Only for Underlying Medium Water)