



Standard Test Method for Misting Properties of Lubricating Fluids¹

This standard is issued under the fixed designation D 3705; the number immediately following the designation indicates the year of original adoption or, in the case of revision, the year of last revision. A number in parentheses indicates the year of last approval. A superscript epsilon (ϵ) indicates an editorial change since the last revision or reapproval.

1. Scope

1.1 This test method covers the determination of the misting characteristics of lubricating fluids.

NOTE 1—This test method should not be used to evaluate fluids containing solid additives such as graphite.

1.2 *This standard does not purport to address all of the safety concerns, if any, associated with its use. It is the responsibility of the user of this standard to establish appropriate safety and health practices and determine the applicability of regulatory limitations prior to use.* For specific hazard statements, see Note 4, Note 5, Note 6, and Note 7.

2. Referenced Documents

2.1 ASTM Standards:

D 91 Test Method for Precipitation Number of Lubricating Oils²

D 235 Specification for Mineral Spirits (Petroleum Spirits) (Hydrocarbon Dry Cleaning Solvent)³

3. Summary of Test Method

3.1 The mist generator is charged with oil and installed in the mist system. The unit is operated for 19 h; the mist generator, line condensate bottles, and reclassified oil collector are weighed before and after the test. The output from the generator and percentages of reclassified oil, line condensate, and stray mist are determined from changes in weight.

NOTE 2—Line condensate is the commonly accepted term used to describe the oil that coalesces in the mist distribution lines. In this test, the oil that coalesces in the 38-mm (1½-in.) tubing and the diagonal 19-mm (¾-in.) tubing is collected and weighed as line condensate. Oil that coalesces in the vertical 19-mm (¾-in.) tubing becomes part of the reclassified oil.

¹ This test method is under the jurisdiction of ASTM Committee D-2 on Petroleum Products and Lubricants and is the direct responsibility of Subcommittee D02.L on Industrial Lubricants.

Current edition approved Oct. 31, 1986. Published December 1986. Originally published as D 3705 – 78. Last previous edition D 3705 – 78.

² *Annual Book of ASTM Standards*, Vol 05.01.

³ *Annual Book of ASTM Standards*, Vol 06.04.

4. Significance and Use

4.1 This test provides a guide for evaluating the misting characteristics of oils for use in industrial mist lubrication systems. The degree of correlation between this test and service performance has not been fully determined.

5. Apparatus

5.1 The basic system consists of the following:

5.1.1 *Oil Mist Generator*,⁴ with special ASTM-ASLE mist head assembly.

5.1.2 *Air Temperature Regulator*.⁵

5.1.3 *Mist Distribution Manifold*, as shown in Fig. 1.

5.1.4 *Mist Reclassifier Fitting*, as shown in Fig. 2.

5.1.5 *Reclassified Oil Collector*, as shown in Fig. 3.

5.2 *Balance*, 20-kg capacity open pan, with 1-g sensitivity.

5.3 *Air Supply*, from a source capable of maintaining an air flow rate up to 2 dm³/s. The air should be dry, oil-free, and filtered through a 1- μ m filter.

NOTE 3—The oil mist generator head and mist reclassifier fitting are available from the Alemite Co. Orders should specify Special ASTM-ASLE mist head and reclassifier fitting.

6. Reagents

6.1 *Stoddard Solvent*, as specified in Specification D 235 (Type 1).

NOTE 4—**Warning:** Flammable.

6.2 *Precipitation Naphtha*, as specified in Method D 91

NOTE 5—**Warning:** Flammable.

7. Preparation of Apparatus

7.1 Thorough cleaning of the apparatus with solvent is required prior to initiating a test on a new oil. For a duplicate test on the same oil, the mist generator should be thoroughly drained but the apparatus need not be cleaned with solvent.

⁴ Alemite No. 383802-4 available from the Alemite Co., Stewart Warner, 1826 West Diversey Parkway, Chicago, IL 60614.

⁵ Alemite thermo-aire unit No. 383808-A4 available from the Alemite Co., Stewart Warner, 1826 West Diversey Parkway, Chicago, IL 60614.

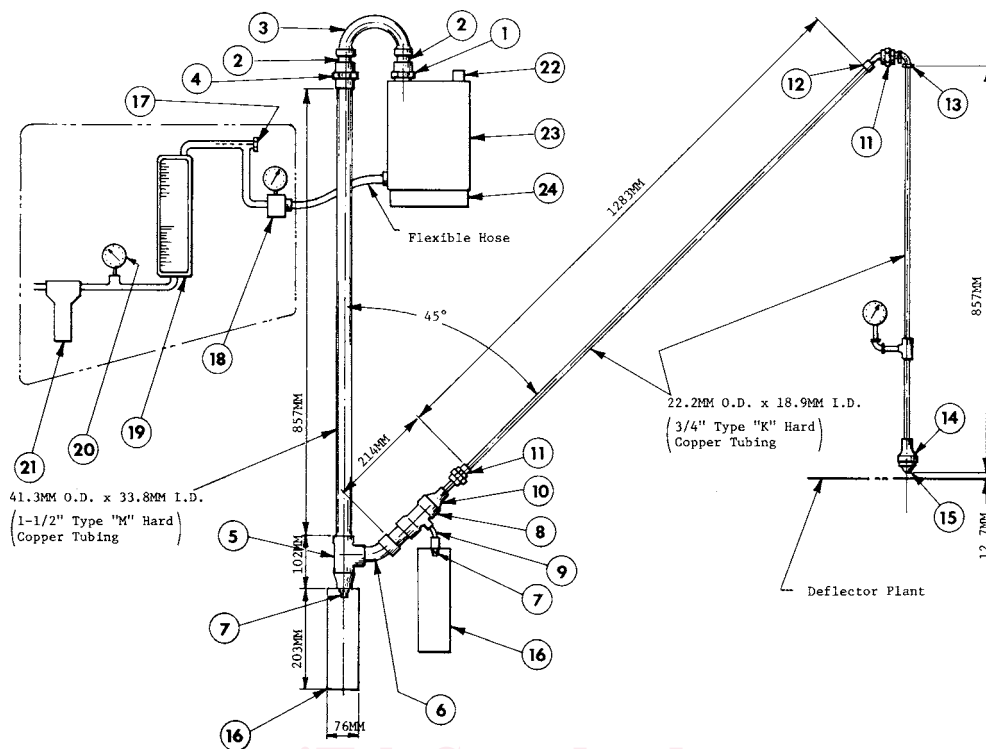

- MIST MANIFOLD**
Proposed ASTM Bill of Materials
- | | | | |
|------|---|------|--|
| (1) | 1 1/2 C × 1 1/2 in. MPT union | (12) | 3/4 in. Fig × C 45 deg Fig. ell |
| (2) | 1 1/2 in. Copper tubing, 3 in. Long | (13) | 3/4 in. Fig × C 90 deg Fig ell |
| (3) | 1 1/2 in. C × C Return bend | (14) | 3/4 C × 1/2 in. F adapter |
| (4) | 1 1/2 in. C Union | (15) | 1/2 in. Reclassifier fitting 12 holes |
| (5) | 1 1/2 × 3/4 × 1 1/2 in. C × C × C tee | (16) | Collector bottles |
| (6) | 1 1/2 in. C 45 deg Fig. ell (straight ell) | (17) | Thermometer |
| (7) | 3/4 in. Fig × MPT adapter | (18) | Pressure regulator with gage |
| (8) | 1 1/2 × 1 1/2 × 3/4 in. C × C × C tee | (19) | Flow meter |
| (9) | 3/4 in. C 45 deg Fig. ell | (20) | Pressure gage |
| (10) | 1 1/2 in. Fig. × 3/4 in. C extended bushing | (21) | Air filter |
| (11) | 3/4 in. C Union | (22) | Oil mist head assembly special ASTM-ASLE |
| | | (23) | Oil mist generator |
| | | (24) | Thermo-aire unit |

FIG. 1 Mist Test Apparatus

7.2 Drain the oil thoroughly and rinse the generator with Stoddard solvent.

NOTE 6—**Warning:** Combustible. Vapor harmful.

7.3 Charge the generator with 2 L of clean Stoddard solvent and mist the Stoddard solvent through the manifold for 30 min.

NOTE 7—**Warning:** Do not use the air heater while misting the Stoddard solvent.

7.4 Drain the Stoddard solvent from the generator, rinse the generator with naphtha, and blow dry with compressed air.

NOTE 8—**Warning:** Extremely flammable. Harmful if inhaled. Vapors may cause flash fire.

7.5 Disconnect the mist head and remove the oil adjustment screw; rinse the head and screw with naphtha and blow dry.

7.6 Remove the reclassifier fitting and rinse it with naphtha; examine the orifices for deposits or buildup. If necessary, the orifices may be cleaned with a fine pipe cleaner.

8. Procedure

8.1 Break-In Period:

8.1.1 Charge the mist generator with 4 ± 0.1 L of test oil. Assemble the test apparatus.

8.1.2 Turn the oil flow adjusting screw clockwise to a fully closed position and then open the screw by turning it counterclockwise to a full open position.

8.1.3 Open the air regulator until a pressure of 37 millibars (37 KPa) is obtained on the manifold gage.

8.1.4 Activate the oil heater and inlet air heater and adjust both to $40 \pm 1^\circ\text{C}$.

8.1.5 Allow the unit to run for 1 h to stabilize.

NOTE 9—The full open position for the oil flow adjusting screw, that is, the position beyond which further opening of the adjusting screw does not increase oil output from the mist generator, should be determined for each mist test unit. The full open position on most test units is attained by turning the adjusting screw counterclockwise 2-1/2 turns from the fully closed position.

8.2 Test Start-Up:

8.2.1 Following the 1-h break-in, deactivate the air and oil heaters and turn off the air supply.

ASTM D 3705

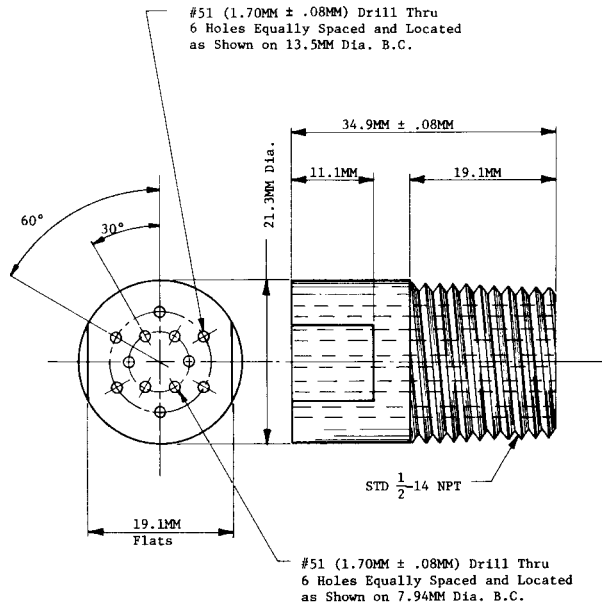

Mat'l. For (1)

Bar 22.2MM Dia. x 34.9MM Long
Brass

FIG. 2 Mist Reclassifier Fitting

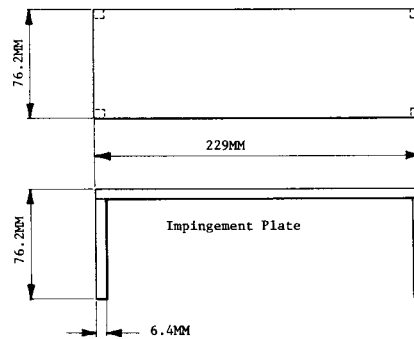
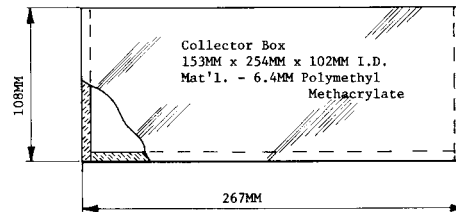
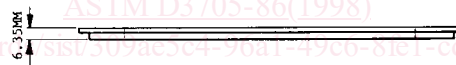
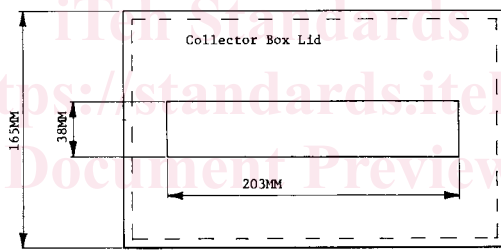

FIG. 3 Reclassified Oil Collector