

ETSI TS 148 056 V13.0.0 (2016-01)



**Digital cellular telecommunications system (Phase 2+);
Base Station Controller - Base Transceiver Station (BSC - BTS)
interface;
Layer 2 specification
(3GPP TS 48.056 version 13.0.0 Release 13)**



Reference

RTS/TSGG-0248056vd00

Keywords

GSM**ETSI**

650 Route des Lucioles
F-06921 Sophia Antipolis Cedex - FRANCE

Tel.: +33 4 92 94 42 00 Fax: +33 4 93 65 47 16

Siret N° 348 623 562 00017 - NAF 742 C
Association à but non lucratif enregistrée à la
Sous-Préfecture de Grasse (06) N° 7803/88

Important notice

The present document can be downloaded from:

<http://www.etsi.org/standards-search>

The present document may be made available in electronic versions and/or in print. The content of any electronic and/or print versions of the present document shall not be modified without the prior written authorization of ETSI. In case of any existing or perceived difference in contents between such versions and/or in print, the only prevailing document is the print of the Portable Document Format (PDF) version kept on a specific network drive within ETSI Secretariat.

Users of the present document should be aware that the document may be subject to revision or change of status.

Information on the current status of this and other ETSI documents is available at

<http://portal.etsi.org/tb/status/status.asp>

If you find errors in the present document, please send your comment to one of the following services:

<https://portal.etsi.org/People/CommiteeSupportStaff.aspx>

Copyright Notification

No part may be reproduced or utilized in any form or by any means, electronic or mechanical, including photocopying and microfilm except as authorized by written permission of ETSI.

The content of the PDF version shall not be modified without the written authorization of ETSI.

The copyright and the foregoing restriction extend to reproduction in all media.

© European Telecommunications Standards Institute 2016.

All rights reserved.

DECT™, **PLUGTESTS™**, **UMTS™** and the ETSI logo are Trade Marks of ETSI registered for the benefit of its Members.
3GPP™ and **LTE™** are Trade Marks of ETSI registered for the benefit of its Members and of the 3GPP Organizational Partners.
GSM® and the GSM logo are Trade Marks registered and owned by the GSM Association.

Intellectual Property Rights

IPRs essential or potentially essential to the present document may have been declared to ETSI. The information pertaining to these essential IPRs, if any, is publicly available for **ETSI members and non-members**, and can be found in ETSI SR 000 314: *"Intellectual Property Rights (IPRs); Essential, or potentially Essential, IPRs notified to ETSI in respect of ETSI standards"*, which is available from the ETSI Secretariat. Latest updates are available on the ETSI Web server (<https://ipr.etsi.org>).

Pursuant to the ETSI IPR Policy, no investigation, including IPR searches, has been carried out by ETSI. No guarantee can be given as to the existence of other IPRs not referenced in ETSI SR 000 314 (or the updates on the ETSI Web server) which are, or may be, or may become, essential to the present document.

Foreword

This Technical Specification (TS) has been produced by ETSI 3rd Generation Partnership Project (3GPP).

The present document may refer to technical specifications or reports using their 3GPP identities, UMTS identities or GSM identities. These should be interpreted as being references to the corresponding ETSI deliverables.

The cross reference between GSM, UMTS, 3GPP and ETSI identities can be found under <http://webapp.etsi.org/key/queryform.asp>.

Modal verbs terminology

In the present document "**shall**", "**shall not**", "**should**", "**should not**", "**may**", "**need not**", "**will**", "**will not**", "**can**" and "**cannot**" are to be interpreted as described in clause 3.2 of the [ETSI Drafting Rules](#) (Verbal forms for the expression of provisions).

"**must**" and "**must not**" are **NOT** allowed in ETSI deliverables except when used in direct citation.

Contents

| | |
|---|-----------|
| Intellectual Property Rights | 2 |
| Foreword..... | 2 |
| Modal verbs terminology..... | 2 |
| Foreword..... | 4 |
| 1 Scope | 5 |
| 2 References | 5 |
| 3 Definitions and abbreviations..... | 6 |
| 4 General description..... | 6 |
| 5 Functional contents | 7 |
| 6 LAPD functions..... | 7 |
| 6.1 Exceptions and modifications..... | 7 |
| 6.1.1 Void | 7 |
| 6.1.2 Command/Response field bit (C/R)..... | 7 |
| 6.1.3 Service Access Point Identifier (SAPI)..... | 7 |
| 6.1.4 TEI for point-to-point data link connection | 8 |
| 6.1.5 Commands and responses..... | 8 |
| 6.1.6 Exchange identification (XID) command/response | 8 |
| 6.1.7 MDL-XID | 8 |
| 6.1.8 PH-DATA, PH DEACTIVATE and PH-ACTIVATE..... | 8 |
| 6.1.9 MPH-ACTIVATE, MPH-DEACTIVATE and MPH-INFORMATION | 8 |
| 6.1.10 Priority indicator..... | 9 |
| 6.1.11 Terminal Endpoint Identifier (TEI) management procedures..... | 9 |
| 6.1.11.1 General | 9 |
| 6.1.11.2 TEI assignment procedure..... | 9 |
| 6.1.11.3 TEI identity verify procedure | 11 |
| 6.1.11.4 Formats and codes..... | 11 |
| 6.1.12 Automatic negotiation of data link layer parameters | 11 |
| 6.1.13 Establishment procedures | 11 |
| 6.1.14 N(S) sequence error | 11 |
| 6.1.15 List of system parameters | 11 |
| 6.1.15.1 Timer T200 | 12 |
| 6.1.15.2 Maximum number of retransmissions (N200) | 12 |
| 6.1.15.3 Maximum number of octets in an information field (N201)..... | 12 |
| 6.1.15.4 Maximum number of transmission of the TEI identity request message (N202)..... | 12 |
| 6.1.15.5 Maximum number of outstanding frames (K)..... | 12 |
| 6.1.15.6 Timer T201 | 12 |
| 6.1.15.7 Timer T202 | 12 |
| 6.1.15.8 Timer T203 | 12 |
| 6.1.16 Data link layer monitor function..... | 13 |
| 6.1.17 Miscellaneous | 13 |
| Annex A (informative): Change History | 14 |
| History | 15 |

Foreword

This Technical Specification has been produced by the 3rd Generation Partnership Project (3GPP).

The contents of the present document are subject to continuing work within the TSG and may change following formal TSG approval. Should the TSG modify the contents of the present document, it will be re-released by the TSG with an identifying change of release date and an increase in version number as follows:

Version x.y.z

where:

- x the first digit:
 - 1 presented to TSG for information;
 - 2 presented to TSG for approval;
 - 3 or greater indicates TSG approved document under change control.
- y the second digit is incremented for all changes of substance, i.e. technical enhancements, corrections, updates, etc.
- z the third digit is incremented when editorial only changes have been incorporated in the document.

iTeh STANDARD PREVIEW
(standards.iteh.ai)
Full standard:
<https://standards.iteh.ai/catalog/standards/sist/62154cc-f084-4f1b-a4e3-94fe0063976d/etsi-ts-148-056-v13.0.0-2016-01>

1 Scope

The present document specifies the link layer used for signalling on the A-bis interface between BSC and BTS. The use and general aspects of the A-bis interface are described in 3GPP TS 48.051 and the interface aspects in 3GPP TS 48.052.

The Link Access Procedure on the D-channel (LAPD) specification used on the A-bis interface in the GSM PLMN is a subset of the EN 300 125 which in turn has less options than the CCITT Recommendation Q.921.

This description contains first the protocol definitions and second the services provided by the layer 2 to the layer 3.

2 References

The following documents contain provisions which, through reference in this text, constitute provisions of the present document.

- References are either specific (identified by date of publication, edition number, version number, etc.) or non-specific.
- For a specific reference, subsequent revisions do not apply.
- For a non-specific reference, the latest version applies. In the case of a reference to a 3GPP document (including a GSM document), a non-specific reference implicitly refers to the latest version of that document *in the same Release as the present document*.

- [1] 3GPP TS 21.905: "Vocabulary for 3GPP Specifications".
- [2] 3GPP TS 48.051: "Base Station Controller - Base Transceiver Station (BSC - BTS) interface; General aspects".
- [3] 3GPP TS 48.052: "Base Station Controller - Base Transceiver Station (BSC - BTS) interface; Interface principles".
- [4] Void.
- [5] Void.
- [6] Void.
- [7] Void.
- [8] Void.
- [9] Void.
- [10] Void.
- [11] Void.
- [12] Void.
- [13] Void.
- [14] Void.
- [15] Void.
- [16] Void.
- [17] Void.
- [18] Void.

- [19] CCITT Recommendation Q.921: "Integrated services digital network (ISDN) user-network interface - Data link layer specification".
- [20] EN 300 125: "Integrated Services Digital Network (ISDN); User-network interface data link layer specification Application of CCITT Recommendations Q.920/I.440 and Q.921/I.441".

3 Definitions and abbreviations

Abbreviations used in the present document are listed in 3GPP TS 21.905.

4 General description

The following information categories are supported by the procedures of this layer 2 Recommendation:

- signalling (including Short Message Service (SMS) information);
- operation and maintenance;
- layer 2 management.

For each of these categories the BSC may have one or more layer 2 links to every TRX and BCF.

The signalling links over the A-bis interface are addressed to the different units by Terminal Endpoint Identifiers (TEI).

The same unit will normally have more than one functional entity. The logical links between different functional entities are identified by functional addresses, the Service Access Points Identifier (SAPI).

Figure 1 shows the architectural model with different layer 2 links.

A number of logical links may be multiplexed on each physical link. The same layer 2 logical link may not be distributed over more than one physical link.

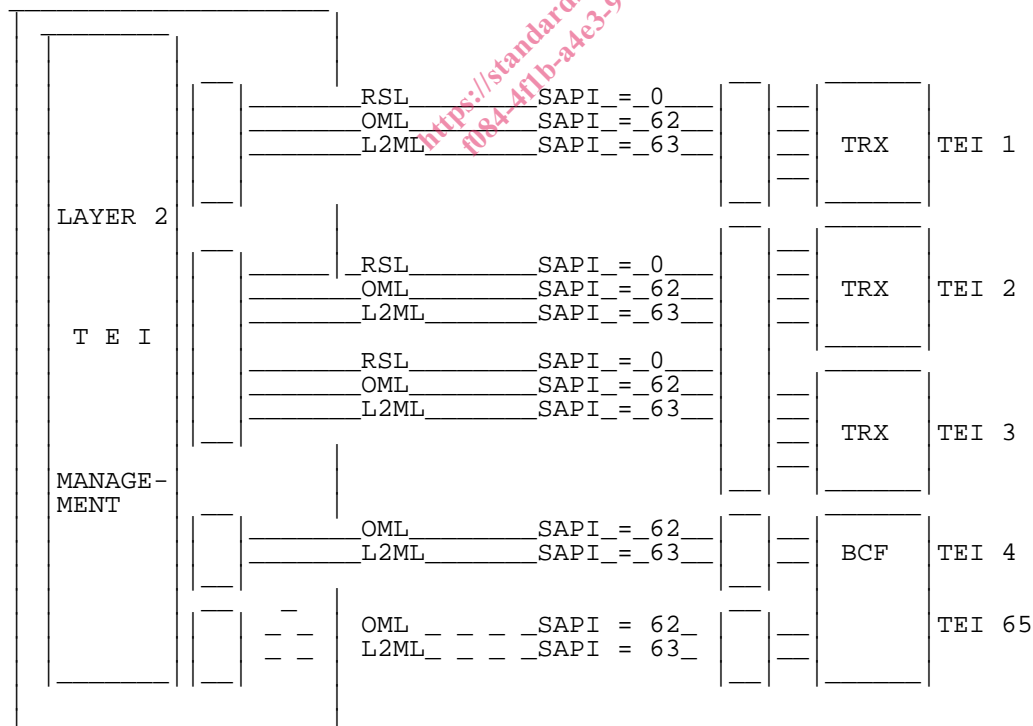

Figure 4.1: An example of Logical Layer 2 links supported by three permanent and one semipermanent links

5 Functional contents

The basic functional content of the layer 2 protocol is:

- transparent layer 2 links and time fill;
- point-to-point dedicated layer 2 links addressing both physical entities and functional entities;
- point-to-multipoint addressed links used for layer 2 management;
- basic functions for TEI assignment and management;
- basic priority functions;
- basic supervision of links when not carrying traffic;
- sequence control;
- transmission error control;
- control of errors not recoverable by retransmission.

6 LAPD functions

The LAPD functions as specified in EN 300 125 are applicable. However, the exceptions and modifications specified in the remainder of the present document shall be used.

6.1 Exceptions and modifications

In the following headlines from EN 300 125 are kept and references are made to the corresponding clause of EN 300 125.

6.1.1 Void

6.1.2 Command/Response field bit (C/R)

(Refer to EN 300 125, part 2, clause 3.3.2)

In GSM PLMN's BSC represents the network side and TRX/BCF the user side of the interface.

6.1.3 Service Access Point Identifier (SAPI)

(Refer to EN 300 125, part 2, clause 3.3.3)

The SAPI values for the A-bis interface are as listed in table 6.1.3.

Table 6.1.3: Allocation of SAPI values and priority classes

| SAPI value | Related layer 3 or layer management entity | Priority |
|------------|--|----------|
| 0 | Radio signalling procedures | 2 |
| 1 | Reserved for packet mode communications using Q.931 call control procedures (Not used in GSM PLMN) | - |
| 16 | Reserved for packet communication conforming to X.25 level 3 procedures (Not used in GSM PLMN) | - |
| 62 | Operation and maintenance procedure | 1 |
| 63 | Layer 2 management procedures | 1 |
| All others | Reserved for future standardization | - |

6.1.4 TEI for point-to-point data link connection

(Refer to EN 300 125, part 2, clause 3.3.4.2).

The remaining Terminal Endpoint Identifier (TEI) values are used for the point-to-point data link connections associated with the addressed Service Access Point (SAP). The range of TEI values shall be allocated as shown in table 6.1.4.

Table 6.1.4: Allocation of TEI values

| TEI value | User type |
|-----------|---|
| 0-63 | TEI assignment for fixed TRX and BCF addresses |
| 64-126 | TEI assignment for additional, TRX or BCF addresses |

NOTE: A BCF is given a separate layer 2 link only if it is not integrated with a TRX.

6.1.5 Commands and responses

(Refer to EN 300 125, part 2, clause 3.6.1)

The XID command and response are not used.

6.1.6 Exchange identification (XID) command/response

(Refer to EN 300 125, part 2, clause 3.6.12)

This functionality is not used.

6.1.7 MDL-XID

(Refer to EN 300 125, part 2, clause 4.1.1.9)

This functionality is not used.

6.1.8 PH-DATA, PH DEACTIVATE and PH-ACTIVATE

(Refer to EN 300 125, part 2, clauses 4.1.1.10 - 4.1.1.12)

This functionality is not relevant.

6.1.9 MPH-ACTIVATE, MPH-DEACTIVATE and MPH-INFORMATION

(Refer to EN 300 125, part 2, clauses 4.1.1.13 - 4.1.1.15)