



Designation: C1367 – 06

Standard Test Method for Dead Load Resistance of a Sealant in Elevated Temperatures¹

This standard is issued under the fixed designation C1367; the number immediately following the designation indicates the year of original adoption or, in the case of revision, the year of last revision. A number in parentheses indicates the year of last reapproval. A superscript epsilon (ϵ) indicates an editorial change since the last revision or reapproval.

1. Scope

1.1 This test method covers a laboratory procedure for determining the heat resistance of sealants. This test method is conducted under dead load in a shear mode. This test method was previously written to include only hot applied sealants.

1.2 The values stated in SI units are to be regarded as the standard. The values given in parentheses are provided for information purposes only.

1.3 *This standard does not purport to address all of the safety concerns, if any, associated with its use. It is the responsibility of the user of this standard to establish appropriate safety and health practices and determine the applicability of regulatory limitations prior to use.*

1.4 The subcommittee with jurisdiction of this standard is not aware of any similar or equivalent ISO standard.

2. Referenced Documents

2.1 *ASTM Standards:*²

B209 Specification for Aluminum and Aluminum-Alloy Sheet and Plate

C717 Terminology of Building Seals and Sealants

C1036 Specification for Flat Glass

C1375 Guide for Substrates Used in Testing Building Seals and Sealants

3. Terminology

3.1 *Definitions*—Definitions of the following terms used in this test method are found in Terminology **C717**, 4.1: adhesive failure, cohesive failure, hot-applied sealant, sealant, and substrate.

3.2 *Definitions of Terms Specific to This Standard*—Definitions of the following terms used in this test method are found in Terminology **C717**, 4.2: applicator and specified temperature.

¹ This test method is under the jurisdiction of ASTM Committee **C24** on Building Seals and Sealants and is the direct responsibility of Subcommittee **C24.30** on Adhesion.

Current edition approved Sept. 1, 2006. Published September 2006. Originally approved in 1997. Last previous edition approved in 2001 as C1367-01. DOI: 10.1520/C1367-06.

² For referenced ASTM standards, visit the ASTM website, www.astm.org, or contact ASTM Customer Service at service@astm.org. For *Annual Book of ASTM Standards* volume information, refer to the standard's Document Summary page on the ASTM website.

4. Summary of Test Method

4.1 The sealant is placed between glass and aluminum substrates. The specimen conditioning time is recorded. The specimen is heated in shear mode with a weight suspended from the specimen. The weight applied and the time that it takes for the specimen to fail is recorded.

5. Significance and Use

5.1 Sealants are generally subjected to stresses in end-use applications. This test method measures the heat resistance of sealants when subjected to dead load shear stresses while under heat.

6. Apparatus

6.1 *Sealant Applicator or Oven*, capable of maintaining the sealant within $\pm 2.8^\circ\text{C}$ ($\pm 5^\circ\text{F}$) of the specified temperature.

6.2 *Substrates:*

6.2.1 Annealed glass that is 25.4 mm wide by 76.2 mm long and 6.35 mm thick (1 in. by 3 in. by 0.25 in.). (See Specification **C1036**.)

6.2.2 Aluminum alloy 5052-H32 that is 25.4 mm wide by 76.2 mm long and 0.508 mm thick (1 in. by 3 in. by 0.020 in.). (See Specification **B209**.)

6.2.3 Other substrates may be used when specified (**Fig. 1**).
6.3 *Template*, to provide 3.28-mm ($1/8$ -in.) sealant thickness (**Fig. 2**).

6.4 *Hot Knife or Spatula*.

6.5 *Test Oven*, capable of maintaining specified temperature within $\pm 2.8^\circ\text{C}$ ($\pm 5^\circ\text{F}$). This oven must contain some apparatus for suspending the specimens in shear mode during testing. Automatic timing devices and recorders may be used to record the time it takes for the test specimens to shear apart.

7. Sampling

7.1 Sealant shall be free of external surface contaminants such as talc, oil, dust, and moisture. Handling of the sealant surfaces in contact with the substrate shall be minimized.

7.2 Condition not less than 250 g of sealant (and sufficient portion of other components, if a multicomponent) in a closed container for 24 h at $23 \pm 2^\circ\text{C}$ ($73.4 \pm 3.6^\circ\text{F}$) and $50 \pm 5\%$ relative humidity.

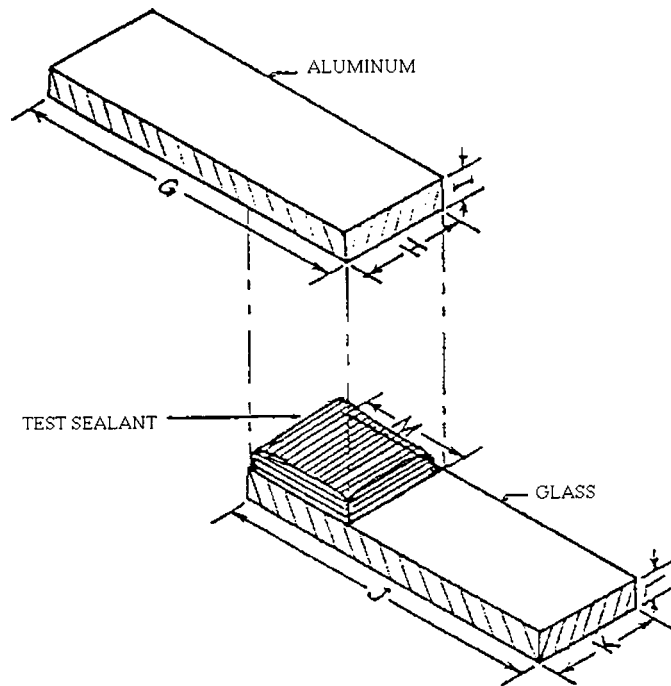

Dimension	Length	
	mm	in.
G, J	76.2 ± 0.25	(3.00 ± 0.01)
H, K, M	25.4 ± 0.25	(1.00 ± 0.01)
I	0.635 ± 0.127	(0.025 ± 0.005)
L	6.35 ± 0.76	(0.250 ± 0.030)

FIG. 1 Assembly of Test Sealant on Substrates

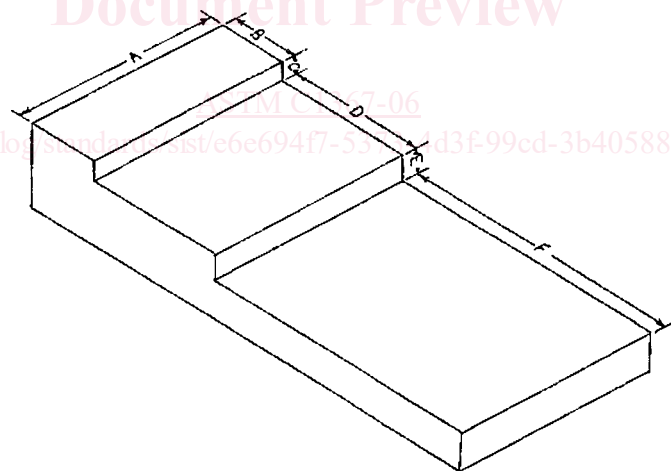

Dimension	Length	
	mm	in.
A	76.2 ± 5	(3.00 ± 0.20)
B	over 12.7	(over 0.50)
C	6.35 ± 0.25	(0.25 ± 0.01)
D	50.8 ± 0.25	(2.00 ± 0.01)
E	8.89 ± 1.02	(0.35 ± 0.84)
F	over 76.2	(over 3.00)

NOTE 1—The template shall be made of a material of low thermal conductivity, such as wood or fiberglass.

FIG. 2 Template

8. Test Specimens

8.1 Prepare five test specimens from the bulk sample by using the applicator or oven method.

8.1.1 Applicator Method:

8.1.1.1 Clean the glass and aluminum surfaces according to the procedures set forth in Guide C1375.