



Standard Test Method for Determination of Ignition Delay and Derived Cetane Number (DCN) of Diesel Fuel Oils by Combustion in a Constant Volume Chamber^{1, 2}

This standard is issued under the fixed designation D 6890; the number immediately following the designation indicates the year of original adoption or, in the case of revision, the year of last revision. A number in parentheses indicates the year of last approval. A superscript epsilon (ε) indicates an editorial change since the last revision or reapproval.

1. Scope

1.1 This automated laboratory test method covers the quantitative determination of the ignition characteristics of conventional diesel fuel oil, oil-sands based fuels, blends of fuel containing biodiesel material, diesel fuel oils containing cetane number improver additives, and is applicable to products typical of ASTM Specification **D 975** grades No. 1-D and 2-D regular and low-sulfur diesel fuel oils, European standard **EN 590**, and Canadian standards CAN/CGSB-3.517 and 3.6-2000. The test method may also be applied to the quantitative determination of the ignition characteristics of diesel fuel blending components.

1.2 This test method measures the ignition delay and utilizes a constant volume combustion chamber with direct fuel injection into heated, compressed air. An equation correlates an ignition delay determination to cetane number by Test Method **D 613**, resulting in a derived cetane number (DCN).

1.3 This test method covers the ignition delay range from 3.3 to 6.4 ms (61 to 34 DCN). The combustion analyzer can measure shorter and longer ignition delays, but precision may be affected.

1.4 The values stated in SI units are to be regarded as the standard.

1.5 *This standard does not purport to address all of the safety concerns, if any, associated with its use. It is the responsibility of the user of this standard to establish appropriate safety and health practices and determine the applicability of regulatory limitations prior to use.*

¹ This test method is under the jurisdiction of ASTM Committee D02 on Petroleum Products and Lubricants and is the direct responsibility of Subcommittee D02.01 on Combustion Characteristics.

Current edition approved Aug. 1, 2006. Published September 2006. Originally approved in 2003. Last previous edition approved in 2004 as D 6890-04.

² This test method is based on IP PM CQ/2001, published in the IP Standard Methods for Analysis and Testing of Petroleum and Related Products and British Standard 2000 Parts. Copyrighted by Energy Institute, 61 New Cavendish Street, London, W1G 7AR, UK. Adapted with permission of Energy Institute.

2. Referenced Documents

2.1 ASTM Standards:³

- D 613** Test Method for Cetane Number of Diesel Fuel Oil
- D 975** Specification for Diesel Fuel Oils
- D 1193** Specification for Reagent Water
- D 4057** Practice for Manual Sampling of Petroleum and Petroleum Products
- D 4175** Terminology Relating to Petroleum, Petroleum Products, and Lubricants
- D 4177** Practice for Automatic Sampling of Petroleum and Petroleum Products
- D 5854** Practice for Mixing and Handling of Liquid Samples of Petroleum and Petroleum Products
- D 6299** Practice for Applying Statistical Quality Assurance Techniques to Evaluate Analytical Measurement System Performance
- D 6300** Practice for Determination of Precision and Bias Data for Use in Test Methods for Petroleum Products and Lubricants
- D 6708** Practice for Statistical Assessment and Improvement of Expected Agreement Between Two Test Methods that Purport to Measure the Same Property of a Material
- E 456** Terminology Relating to Quality and Statistics

2.2 ISO Standards:⁴

- ISO 4010** Diesel Engines—Calibrating Nozzle, Delay Pintle Type
- ISO 4259** Petroleum products—Determination and application of precision data in relation to methods of test

2.3 EN Standard:

³ For referenced ASTM standards, visit the ASTM website, www.astm.org, or contact ASTM Customer Service at service@astm.org. For *Annual Book of ASTM Standards* volume information, refer to the standard's Document Summary page on the ASTM website.

⁴ Available from American National Standards Institute, 25 W. 43rd St., 4th floor, New York, NY 10036.

EN 590 Automotive Fuels—Diesel—Requirements and Test Methods⁵

2.4 *Energy Institute Standard:*

IP 41 Ignition Quality of Diesel Fuels—Cetane Engine Test Method⁶

2.5 *Canadian Standards:*

CAN/CGSB-3.517-2000 Automotive Low Sulfur Diesel Fuel—Specification⁷

CAN/CGSB 3.6-2000 Automotive Diesel Fuel—Specification⁷

3. Terminology

3.1 Definitions:

3.1.1 *accepted reference value (ARV), n*—value that serves as an agreed-upon reference for comparison and that is derived as (1) a theoretical or established value, based on scientific principles, (2) an assigned value, based on experimental work of some national or international organization, such as the U.S. National Institute of Standards and Technology (NIST), or (3) a consensus value, based on collaborative experimental work under the auspices of a scientific or engineering group. **E 456**

3.1.1.1 *Discussion*—In the context of this test method, accepted reference value is understood to apply to the ignition delay of specific reference materials determined under reproducibility conditions by collaborative experimental work.

3.1.2 *cetane number, n*—measure of the ignition performance of a diesel fuel oil obtained by comparing it to reference fuels in a standardized engine test. **D 4175**

3.1.2.1 *Discussion*—In the context of this test method, cetane number is that defined by Test Method **D 613/IP 41**.

3.1.3 *check standard, n*—in *QC testing*, material having an accepted reference value used to determine the accuracy of a measurement system. **D 6299**

3.1.3.1 *Discussion*—In the context of this test method, check standard refers to heptane.

3.1.4 *quality control (QC) sample, n*—for use in quality assurance programs to determine and monitor the precision and stability of a measurement system, a stable and homogeneous material having physical or chemical properties, or both, similar to those of typical samples tested by the analytical measurement system. The material is properly stored to ensure sample integrity, and is available in sufficient quantity for repeated, long term testing. **D 6299**

3.2 Definitions of Terms Specific to This Standard:

3.2.1 *calibration reference material, n*—pure chemical having an assigned ignition delay accepted reference value.

3.2.2 *charge air, n*—compressed air at a specified pressure introduced to the combustion chamber at the beginning of each test cycle.

3.2.3 *charge air temperature, n*—temperature, in °C, of the air inside the combustion chamber.

3.2.4 *combustion analyzer, n*—integrated compression ignition apparatus to measure the ignition characteristics of diesel fuel oil.

3.2.5 *derived cetane number (DCN), n*—number calculated using an equation that correlates a combustion analyzer ignition delay result to cetane number by Test Method **D 613**.

3.2.6 *ignition delay (ID), n*—that period of time, in milliseconds (ms), between the start of fuel injection and the start of combustion as determined using the specific combustion analyzer applicable for this test method.

3.2.6.1 *Discussion*—In the context of this test method, start of fuel injection is interpreted as the initial movement or lift of the injector nozzle needle as measured by a motion sensor; start of combustion is interpreted as that point in the combustion cycle when a significant and sustained increase in rate-of-change in pressure, as measured by a pressure sensor in the combustion chamber, ensures combustion is in progress.

3.2.7 *operating period, n*—the time, not to exceed 12 h, between successive calibration or QC testing, or both, of the combustion analyzer by a single operator.

3.3 Abbreviations:

3.3.1 *ARV*—accepted reference value.

3.3.2 *CN*—cetane number.

3.3.3 *DCN*—derived cetane number.

3.3.4 *ID*—ignition delay.

3.3.5 *QC*—quality control.

4. Summary of Test Method

4.1 A small specimen of diesel fuel oil is injected into a heated, temperature-controlled constant volume chamber, which has previously been charged with compressed air. Each injection produces a single-shot, compression ignition combustion cycle. ID is measured using sensors that detect the start of fuel injection and the start of significant combustion for each cycle. A complete sequence comprises 15 preliminary cycles and 32 further cycles. The ID measurements for the last 32 cycles are averaged to produce the ID result. An equation correlates the ID result to cetane number by Test Method **D 613**, resulting in a DCN.

5. Significance and Use

5.1 The ID and DCN values determined by this test method can provide a measure of the ignition characteristics of diesel fuel oil in compression ignition engines.

5.2 This test can be used by engine manufacturers, petroleum refiners and marketers, and in commerce as a specification aid to relate or match fuels and engines.

5.3 The relationship of diesel fuel oil DCN determinations to the performance of full-scale, variable-speed, variable-load diesel engines is not completely understood.

5.4 This test may be applied to non-conventional fuels. It is recognized that the performance of non-conventional fuels in full-scale engines is not completely understood. The user is therefore cautioned to investigate the suitability of ignition characteristic measurements for predicting performance in full-scale engines for these types of fuels.

5.5 This test determines ignition characteristics and requires a sample of approximately 100 mL and a test time of approximately 20 min on a fit-for-use instrument.

⁵ Available from European Committee for Standardization. Central Secretariat: rue de Stassart, 36, B-1050 Brussels, Belgium.

⁶ Available from Institute of Petroleum, 61 New Cavendish St., London, W1G 7AR, U.K.

⁷ Available from the Canadian General Standards Board, Gatineau, Canada, K1A 1G6.

6. Interferences

6.1 Minimize exposure of sample fuels, calibration reference materials, QC samples, and check standard to sunlight or fluorescent lamp UV emissions to minimize induced chemical reactions that can affect ignition delay measurements.⁸

6.1.1 Exposure of these fuels and materials to UV wavelengths shorter than 550 nanometers for a short period of time may significantly affect ignition delay measurements.

NOTE 1—The formation of peroxide and radicals can effect ignition delay measurement. These formations are minimized when the sample or material is stored in the dark in a cold room at a temperature of less than 10°C, and covered by a blanket of nitrogen.

7. Apparatus

7.1 *General*—This test method uses an integrated automated analytical measurement system⁹ comprised of: (1) a constant volume compression ignition combustion chamber with external electrical heating elements, suitable insulation and pneumatically actuated intake and exhaust valves, (2) a heated, pneumatically actuated fuel injection system¹⁰ with pump, injector nozzle assembly, and associated sample reservoir, (3) a coolant system with a liquid-to-air heat exchanger, filter, circulating pump and flow control valves, (4) temperature thermocouples, pressure gages and sensors, an injector nozzle needle motion sensor, compressed gas pressure regulators, control valves, pneumatic actuator components, and solenoid valves, and (5) a computer to control test sequencing, acquire and accumulate sensor signal data, provide processing calculations, and automatically output a printed report of some important test parameters (see Fig. 1).

7.2 See Annex A2, Combustion Analyzer Equipment Description and Specifications, for detailed information.

7.3 Compressed Gas Pressure Regulators:

7.3.1 *Charge Air Regulator*, a two-stage regulator capable of controlling the downstream pressure to a minimum pressure of 2.2 MPa.

7.3.2 *Actuator Utility Compressed Air Regulator*, a two-stage regulator capable of controlling the downstream pressure to a minimum pressure of 1.3 MPa.

7.3.3 *Fuel Reservoir Utility Compressed Nitrogen Regulator*, a single or two-stage regulator capable of controlling the downstream pressure to a minimum pressure of 350 kPa.

7.4 Auxiliary Apparatus:

7.4.1 *Diesel Fuel Oil Sample Filter*, a single-use glass fiber, polytetrafluorethylene (PTFE), or nylon filter with a nominal pore size of 3 to 5 micrometers (µm) for use with a glass syringe.

7.4.2 *Syringe*, a glass syringe of a minimum volume of 100 mL.

8. Reagents and Materials

8.1 Calibration Reference Materials:

8.1.1 *Heptane (n-heptane)*, with a minimum purity of 99.5 volume percent. The assigned ID_{ARV} for this material is 3.78 ms. (**Warning**—Flammable. Vapor harmful. Vapor may cause flash fire.)

8.1.2 *Methylcyclohexane*, with a minimum purity of 99.0 volume percent. The assigned ID_{ARV} for this material is 10.4 ms. (**Warning**—Flammable. Vapor harmful. Vapor may cause flash fire.)

8.2 Check Standard:

8.2.1 *Heptane (n-heptane)*, with a minimum purity of 99.5 volume percent. The assigned ID_{ARV} for this material is 3.78 ms. (**Warning**—Flammable. Vapor harmful. Vapor may cause flash fire.)

8.3 *Quality Control Sample*, a stable and homogeneous diesel fuel oil having physical and chemical properties similar to those of typical sample fuels routinely tested. (**Warning**—Combustible. Vapor harmful.)

8.4 *Charge Air*, compressed air containing 20.9 ± 1.0 volume percent oxygen, less than 0.003 volume percent hydrocarbons, and less than 0.025 volume percent water. For charge air cylinders supplied with a blend of oxygen and nitrogen, it is required that a quality control test be performed after an air cylinder has been changed. (**Warning**—Compressed gas under high pressure that supports combustion.)

8.5 *Coolant System Fluid*, a 50:50 volume mixture of water and commercial ethylene glycol-based antifreeze. (**Warning**—Poison. May be harmful or fatal if inhaled or swallowed.)

8.5.1 *Antifreeze*, commercial automotive cooling system ethylene glycol-based solution.

8.5.2 *Water*, distilled or reagent-grade, conforming to Specification D 1193, Type IV.

8.6 *Actuator Utility Compressed Air*, oil free compressed air having less than 0.1 volume percent water supplied at a minimum sustained pressure of 1.5 MPa. (**Warning**—Compressed gas under high pressure that supports combustion.)

8.7 *Fuel Reservoir Utility Compressed Nitrogen*, compressed nitrogen having a minimum purity of 99.9 volume percent. (**Warning**—Compressed gas under high pressure.)

9. Sampling and Test Specimen Preparation

9.1 Sampling:

9.1.1 Collect diesel fuel oil samples in accordance with Practices D 4057 or D 4177.

9.1.1.1 Collect and store diesel fuel samples in a suitable container such as a dark brown bottle, a metal can, or a minimally reactive plastic container to minimize exposure to UV emissions.

9.1.2 Refer to Practice D 5854 for appropriate information relating to the mixing and handling of diesel fuel oil samples.

9.2 Test Specimen Preparation:

⁸ Supporting data have been filed at ASTM International Headquarters and may be obtained by requesting Research Report RR: D02-1502.

⁹ The sole source of supply of the combustion analyzer known to the committee at this time is Advanced Engine Technology Ltd. (AET), 17 Fitzgerald Road, Suite 102, Ottawa, Canada, K2H 9G1. If you are aware of alternative suppliers, please provide this information to ASTM International Headquarters. Your comments will receive careful consideration at a meeting of the responsible technical committee,¹ which you may attend.

¹⁰ The fuel injection system is covered by a patent. Interested parties are invited to submit information regarding the identification of an alternative(s) to this patented item to the ASTM International Headquarters. Your comments will receive careful consideration at a meeting of the responsible technical committee,¹ which you may attend.

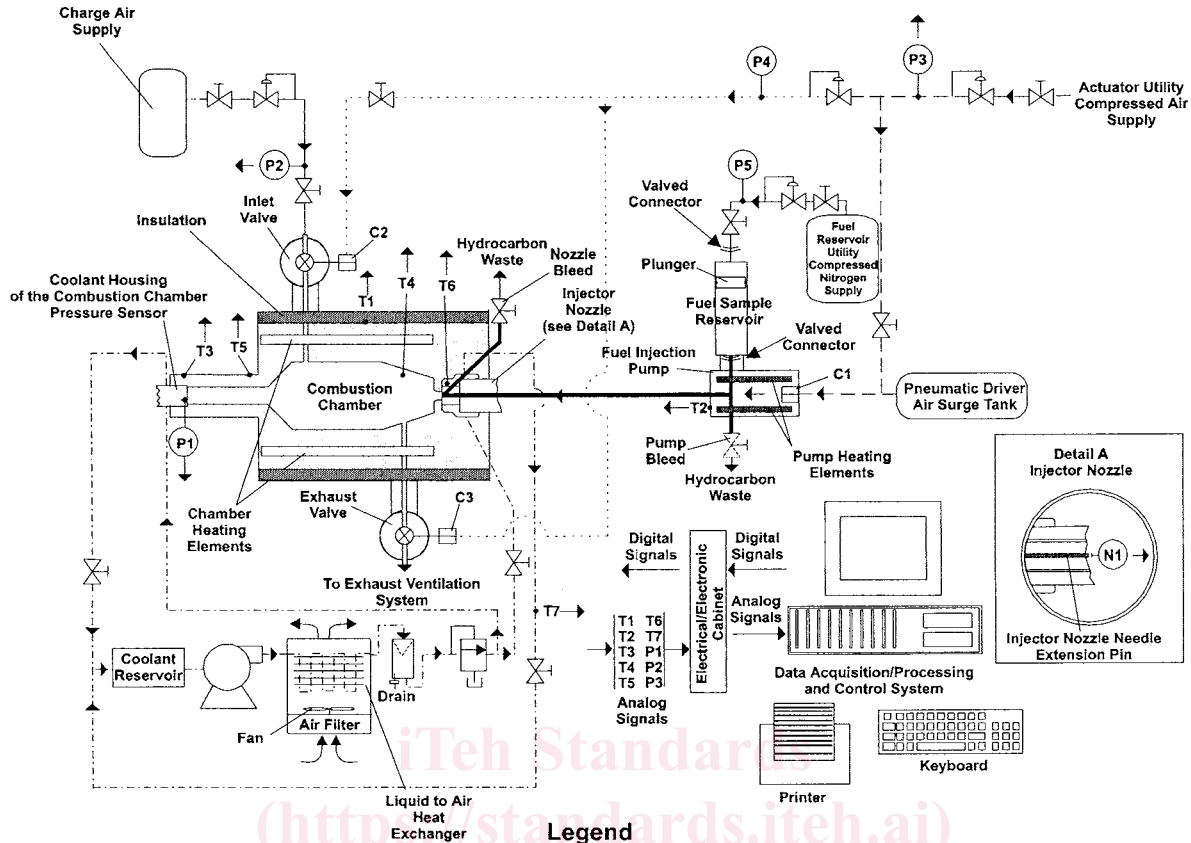

- Legend**
- | | |
|---|---|
| P1: Combustion Chamber Pressure | T4: Charge Air Temperature |
| P2: Charge Air Pressure | T5: (used for diagnostic functions) |
| P3: Injection Actuator Air Pressure | T6: Injector Nozzle Coolant Passage Temperature |
| P4: Inlet/Exhaust Valve Actuator Air Pressure (Gauge) | T7: Coolant Return Temperature |
| P5: Sample Fuel Reservoir Pressure (Gauge) | N1: Injector Nozzle Needle Motion Sensor |
| T1: Combustion Chamber Outer Surface Temperature | C1: Digital Signal - Fuel Injection Actuator |
| T2: Fuel Injection Pump Temperature | C2: Digital Signal - Inlet Valve Actuator |
| T3: Combustion Chamber Pressure Sensor Temperature | C3: Digital Signal - Exhaust Valve Actuator |
-
- | | |
|---|---|
| ----- : Charge Air Line | ----- : Fuel Injection Pump Driver Air Line |
| ----- : Inlet/Exhaust Valve Actuator Air Line | ----- : Coolant System Line |
| ----- : Fuel Reservoir Utility Nitrogen Line | ----- : High Pressure Fuel Line |

FIG. 1 Combustion Analyzer Schematic

9.2.1 *Sample Fuel Temperature*—Condition the diesel fuel sample before opening the storage container, so that it is at room temperature, typically 18 to 32°C.

9.2.2 *Filtration*—Prepare a test specimen by filtering at least 100 mL of diesel fuel oil sample through a nominal 3 to 5 µm porosity filter element using a glass syringe.

9.2.2.1 Collect the specimen in a dark brown bottle, metal can or minimally reactive plastic container.

10. Basic Apparatus Settings and Standard Operating Conditions

10.1 Installation of the apparatus requires placement on a level floor and connection of all utilities. Engineering and technical support for this function is required, and the user

shall be responsible to comply with all local and national codes and installation requirements.

10.2 Operation of the combustion analyzer, associated equipment, instrumentation and computer system requires setting a series of testing variables to prescribed specifications. Some of these settings are established by component specifications, others are operating conditions that are monitored/controlled by the computer software or by operator adjustment.

10.3 Settings Based on Component Specifications:

10.3.1 *Injector Nozzle Opening Pressure*—Each time the nozzle assembly is reassembled or replaced, or both, set the pressure-adjusting nut to release fuel in conformance with the requirements in the manufacturer's equipment manual, using

an injector nozzle tester. For additional details, refer to the instruction manual of the manufacturer.

10.3.2 *Injector Nozzle Motion Sensor Position*—Manually position the motion sensor while visually observing the nozzle needle movement signal on the computer monitor (see Fig. A4.1). The criteria for optimized setting are as follows:

10.3.2.1 The signal prior to the steep increase in needle lift is required to indicate some signal noise. If the signal trace is flat and constant, the motion sensor is too far away from the nozzle needle extension pin.

10.3.2.2 The peak of the steep increase in signal level is required to be visible on the computer monitor screen. If the signal peak is flat, the motion sensor is too close to the nozzle needle extension pin. For additional details, refer to the instruction manual of the manufacturer.

10.3.3 *Injector Nozzle Coolant Passage Thermocouple Position*—Proper positioning of the thermocouple in the injector nozzle coolant passage is set by installing a compression fitting nut and associated ferrule on the stainless steel sheath of the thermocouple, crimping the ferrule on the sheath using a specialized depth setting tool to establish the correct depth of penetration. For additional details, refer to the instruction manual of the manufacturer.

10.3.4 *Charge Air Thermocouple Position*—Proper positioning of the thermocouple in the combustion chamber is set by installing a compression fitting nut and associated ferrule on the stainless steel sheath of the thermocouple, crimping the ferrule on the sheath using a specialized depth setting tool to establish the correct depth of penetration. For additional details, refer to the instruction manual of the manufacturer.

10.3.5 *Combustion Chamber Pressure Drop Rate of Charge Air*, less than 3.5 kPa/s, as measured during the check of the sealing integrity of the combustion chamber (see A3.4).

10.4 *Standard Operating Conditions:*

10.4.1 *Charge Air Pressure (P2)*, 2.137 ± 0.007 MPa.

10.4.2 *Charge Air Temperature (T4)*, $545 \pm 30^\circ\text{C}$.

10.4.2.1 The difference in temperature ($T4_{max} - T4_{min}$) as determined and recorded by the computer, shall be less than 2.5°C during a 32 combustion cycle measurement determination.

10.4.3 *Combustion Chamber Outer Surface Temperature (T1)*—Initially set by the manufacturer, the surface temperature is monitored and controlled by the computer. Operator adjustment of the controller set-point is required, in accordance with the calibration procedure.

10.4.4 *Combustion Chamber Pressure Sensor Temperature (T3)*, $130 \pm 20^\circ\text{C}$.

10.4.4.1 The difference in temperature ($T3_{max} - T3_{min}$) as determined and recorded by the computer, shall be less than 8.0°C during a 32 combustion cycle measurement determination.

10.4.5 *Coolant Return Temperature (T7)*, $40 \pm 10^\circ\text{C}$.

10.4.6 *Fuel Sample Reservoir Pressure (P5)*, 345 ± 35 kPa. Visually check the gage reading, as this parameter is not recorded by the data acquisition system.

10.4.7 *Fuel Injection Pump Temperature (T2)*, $35 \pm 3^\circ\text{C}$.

10.4.8 *Injector Nozzle Coolant Passage Temperature (T6)*—The maximum ($T6_{max}$) and minimum ($T6_{min}$) temperatures as

determined and recorded by the computer, shall be within $50 \pm 4.0^\circ\text{C}$ during a 32 combustion cycle measurement determination.

10.4.9 *Injection Actuator Air Pressure (P3)*, 1.21 ± 0.03 MPa.

10.4.10 *Inlet/Exhaust Valve Actuator Air Pressure (P4)*, 480 ± 35 kPa. Visually check the gage reading, as this parameter is not recorded by the data acquisition system.

11. Calibration and Quality Control Testing

11.1 *Calibration*—Calibrate the combustion analyzer for only the following reasons: (1) after it is installed and commissioned, (2) once a week, (3) after replacement of critical parts or components of combustion chamber assembly (see A2.2), fuel injection system (see A2.3) or instrument sensors (see A2.4), (4) after calibration of the data acquisition board, injection actuator air pressure sensor or charge air pressure sensor, (5) whenever check standard or QC sample determinations are not acceptable.

11.2 *Precalibration Procedures:*

11.2.1 Clean the combustion chamber pressure sensor assembly (see A3.3).

11.2.2 If necessary, start and warm-up the combustion analyzer (see A3.1).

11.3 *Calibration Procedure*—Two filtered calibration reference materials are tested: (1) heptane to affirm that the combustion chamber charge air temperature setting produces ignition delay measurements for this material that are within specification limits and, (2) methylcyclohexane to affirm that the measurement sensitivity of the combustion analyzer produces ignition delay measurements for this material that are within specification limits.

11.3.1 *Heptane Calibration Reference Material*—Perform three consecutive ignition delay determinations.

11.3.1.1 The average of three acceptable ID results is required to be within 3.78 ± 0.01 ms.

11.3.1.2 If the average ID is outside the limits, the combustion chamber outer surface temperature controller set-point requires adjustment to cause a change in the combustion chamber charge air temperature.

NOTE 2—ID increases when the combustion chamber outer surface temperature decreases and vice versa.

11.3.1.3 If the temperature controller set-point adjustment from the previous setting, exceeds $\pm 4^\circ\text{C}$, a system malfunction is suspected and diagnostic procedures to determine and remedy the problem are recommended. Refer to the instructions provided by the manufacturer.

NOTE 3—After a change of charge air cylinders that employ a blend of oxygen and nitrogen, a temperature controller set-point adjustment beyond 4°C can accommodate the extreme limits of the 20.9 ± 1.0 volume percent oxygen in the blend.

11.3.1.4 After a temperature controller set-point adjustment, wait at least 10 min before initiating a new calibration so that the combustion analyzer attains thermal equilibrium.

11.3.1.5 To be an acceptable data set, each single result is required to be within 3.78 ± 0.06 ms.

11.3.1.6 If any of the three results is outside the limits, a system malfunction is suspected and diagnostic procedures to

determine and remedy the problem are recommended before performing a new calibration. Refer to the instructions provided by the manufacturer.

11.3.2 *Methylcyclohexane Calibration Reference Material*—Perform two consecutive ignition delay determinations.

11.3.2.1 To be an acceptable data set, each single result is required to be within 10.4 ± 0.6 ms and the average of the two results is required to be within 10.4 ± 0.5 ms.

11.3.2.2 If either of the two single results or the average of the two results is outside the respective limits, system performance is unacceptable and it is recommended that diagnostic procedures be used to determine and remedy the problem before performing a new calibration. Refer to the instructions provided by the manufacturer.

11.3.3 The combustion analyzer calibration is complete when both heptane and methylcyclohexane data sets are acceptable.

11.4 *Quality Control (QC Testing)*—Conduct a regular statistical quality assurance (quality control) program in accordance with the techniques of Practice D 6299 or equivalent.

11.4.1 This test method requires quality control testing at the beginning of each operating period by a single ignition delay determination for both the check standard (heptane) and one QC sample.

11.4.2 The QC sample is a typical diesel fuel oil having an ignition delay that represents the primary range of use for the combustion analyzer.

11.4.2.1 If the combustion analyzer is used for testing fuels having a very wide range of ignition delay, it may be useful to have a second QC sample of a different ignition delay.

11.4.3 For locations using blends of oxygen and nitrogen as the source for charge air, conduct a QC test whenever there is a change from one cylinder to another.

NOTE 4—The oxygen content of the new oxygen and nitrogen blend may differ from that of the previous source and can have a significant effect on ID measurements.

11.5 *Check Standard*—Perform a single ignition delay determination for filtered heptane.

11.5.1 This determination is acceptable if it satisfies the limits protocol specified in Practice D 6299 or equivalent.

11.5.2 Prior to having established ignition delay tolerances for heptane in accordance with Practice D 6299 or equivalent, use warning limits of ± 0.07 ms and action limits of ± 0.106 ms, based on the average of the three acceptable ID results for heptane, as per 11.3.1.

NOTE 5—The warning and action limits for heptane were determined by analysis of round robin test data.¹¹

11.6 *QC Sample*—Perform a single ignition delay determination for the filtered QC sample.

11.6.1 This determination is acceptable if it satisfies the limits protocol specified in Practice D 6299 or equivalent.

11.7 The combustion analyzer is fit-for-use when both the check standard (heptane) and the QC sample ignition delay

determinations are acceptable. If the ignition delay determination for either material is not acceptable, conduct a new calibration before performing further ignition delay determinations.

12. Procedure

12.1 *Operating Period Procedure:*

12.1.1 If necessary, warm-up the combustion analyzer (see A3.1).

12.1.2 Check the sealing integrity of the combustion chamber (see A3.4).

12.1.3 Check that the combustion analyzer is fit-for use by performing a quality control test (see 11.4).

12.2 *Test Procedure:*

12.2.1 Filter the diesel fuel sample at room temperature, using a glass syringe and single-use filter element, to prepare a test specimen of at least 100 mL.

12.2.2 Flush the fuel system with the specimen (see A3.2.2).

12.2.3 Fill and purge the fuel system with the specimen (see A3.2.3).

12.2.4 Initiate an automatic ignition delay determination using the appropriate computer command (see Annex A4 for detailed information about the test sequence).

12.2.5 Check that all standard operating conditions are in compliance.

12.2.6 If operating conditions are not in compliance, make the required adjustments and return to 12.2.3.

12.2.7 Record the average ignition delay to the nearest thousandth.

12.3 Discharge unused specimen and clean the fuel system (see A3.2.4) to prepare for (1) the next specimen determination, or (2) combustion analyzer shut down (see A3.5).

13. Calculation

13.1 Calculate the derived cetane number, DCN, from average ignition delay, ID (ms), recorded as in 12.2.7 using Eq 1:¹²

$$DCN = 4.460 + 186.6 / ID \quad (1)$$

13.2 Record the DCN to the nearest 0.1.

13.3 The derivation and maintenance of Eq 1 is described in Annex A5.

14. Report

14.1 Report the following information:

14.1.1 A reference to this standard,

14.1.2 The sample identification,

14.1.3 The date of the test,

14.1.4 The ID result to three significant figures,

14.1.5 The DCN result to the nearest tenth,

14.1.6 The test's average charge air temperature to the nearest tenth °C, and

14.1.7 Any deviation, by agreement or otherwise, from the specified procedures.

¹¹ Supporting data have been filed at ASTM International Headquarters and may be obtained by requesting Research Report RR: D02-1532.

¹² Supporting data have been filed at ASTM International Headquarters and may be obtained by requesting Research Report RR: D02-1602.