



# SLOVENSKI STANDARD

## SIST ISO 730-2:1995

01-april-1995

---

### Kmetijski kolesni traktorji - Tritočkovno priključno drogovje - 2. del: Kategorija 1N (ozki priklop)

Agricultural wheeled tractors -- Three-point linkage -- Part 2: Category 1 N (Narrow hitch)

Tracteurs agricoles à roues -- Attelage trois points -- Partie 2: Catégorie 1 N (Attelage étroit)

**STANDARD PREVIEW**  
**(standards.iteh.ai)**

Ta slovenski standard je istoveten z: **ISO 730-2:1979**

SIST ISO 730-2:1995  
<https://standards.iteh.ai/catalog/standards/sist/90846e07-c497-424a-a3c2-064fbbdeb4d0/sist-iso-730-2-1995>

---

#### **ICS:**

65.060.10      Kmetijski traktorji in prikolice      Agricultural tractors and  
trailed vehicles

**SIST ISO 730-2:1995**

**en**

**iTeh STANDARD PREVIEW**  
**(standards.iteh.ai)**

SIST ISO 730-2:1995

<https://standards.iteh.ai/catalog/standards/sist/90846e07-e497-424a-a3c2-064fbbdeb4d0/sist-iso-730-2-1995>

---

International Standard



730/II

---

INTERNATIONAL ORGANIZATION FOR STANDARDIZATION • МЕЖДУНАРОДНАЯ ОРГАНИЗАЦИЯ ПО СТАНДАРТИЗАЦИИ • ORGANISATION INTERNATIONALE DE NORMALISATION

---

## Agricultural wheeled tractors — Three-point linkage — Part II : Category 1 N (Narrow hitch)

*Tracteurs agricoles à roues — Attelage trois points — Partie II : Catégorie 1 N (Attelage étroit)*

First edition — 1979-05-01

**ITeH STANDARD PREVIEW**  
**(standards.iteh.ai)**

[SIST ISO 730-2:1995](https://standards.iteh.ai/catalog/standards/sist/90846e07-e497-424a-a3c2-064fbbdeb4d0/sist-iso-730-2-1995)

<https://standards.iteh.ai/catalog/standards/sist/90846e07-e497-424a-a3c2-064fbbdeb4d0/sist-iso-730-2-1995>

---

UDC 631.372 : 629.11.013

Ref. No. ISO 730/II-1979 (E)

Descriptors : agricultural machinery, tractors, coupling, specifications, dimensions, lifting powers.

**FOREWORD**

ISO (the International Organization for Standardization) is a worldwide federation of national standards institutes (ISO member bodies). The work of developing International Standards is carried out through ISO technical committees. Every member body interested in a subject for which a technical committee has been set up has the right to be represented on that committee. International organizations, governmental and non-governmental, in liaison with ISO, also take part in the work.

Draft International Standards adopted by the technical committees are circulated to the member bodies for approval before their acceptance as International Standards by the ISO Council.

International Standard ISO 730/II was developed by Technical Committee ISO/TC 23, *Tractors and machinery for agriculture and forestry*, and was circulated to the member bodies in June 1977.

ITEH STANDARD PREVIEW  
(standards.iteh.ai)

It has been approved by the member bodies of the following countries :

|                |                        |                       |
|----------------|------------------------|-----------------------|
| Australia      | Germany, F. R.         | Romania               |
| Austria        | India                  | South Africa, Rep. of |
| Belgium        | Iran                   | Spain                 |
| Bulgaria       | Italy                  | Sweden                |
| Chile          | Korea, Dem. P. Rep. of | Switzerland           |
| Czechoslovakia | Mexico                 | Turkey                |
| Denmark        | New Zealand            | United Kingdom        |
| Finland        | Poland                 | USSR                  |
| France         | Portugal               | Yugoslavia            |

The member bodies of the following countries expressed disapproval of the document on technical grounds :

Canada  
USA

# Agricultural wheeled tractors — Three-point linkage — Part II : Category 1 N (Narrow hitch)

## 1 SCOPE

This International Standard specifies the requirements for the attachment of implements or equipment to the rear of narrow agricultural wheeled tractors by means of a three-link hitch in association with a power lift.

of the mast in a vertical plane. It is measured as the maximum and minimum heights of the lower hitch points above the ground between which a mast of height 360 mm can be adjusted to any inclination between the vertical and  $10^\circ$  to the vertical towards the rear.

## 2 FIELD OF APPLICATION

This International Standard applies to narrow agricultural wheeled tractors with a maximum power at the drawbar<sup>1)</sup> up to 35 kW.

## 5 DIMENSIONS<sup>4)</sup>

## 3 REFERENCES

ISO 789/1, *Agricultural tractors — Test procedures — Part 1 : Power tests.*<sup>2)</sup>

ISO 730/1, *Agricultural wheeled tractors — Three-point linkage — Part 1 : Categories 1, 2 and 3.*

### 5.1 Hitch points and zone around the hitch points

The dimensions concerning the hitch points shall be as given in table 2 and those concerning the zone around the hitch points shall be as given in table 1.

### 5.2 Lift, power lift, and levelling adjustments

The ranges of lift, power lift and levelling adjustments shall be as given in table 3.

## 4 DEFINITIONS

### 4.1 General

See ISO 730/1.

### 4.2 Components of the linkage

See ISO 730/1.

### 4.3 Dimensional characteristics of the linkage

See ISO 730/1, except definition 21; for the purposes of the present document the following definition applies :

**21 mast adjustment<sup>3)</sup>** : The usable range of movement

## 6 POWER LIFT CAPACITY

A minimum lift force of 300 N for each drawbar power unit (kW) shall be available at a distance of 610 mm to the rear of the hitch points.

NOTE — The above mentioned value relates to 90 % of the hydraulic relief valve pressure setting and the recommended mast height.

When determining the lift force, a minimum angle of  $10^\circ$  between the vertical and the mast shall be observed; see figure 1.

1) As given in ISO 789/1.

2) At present at the stage of draft. (Revision of ISO/R 789-1968.)

3) Adjustment of the mast controls the pitch of the implement. Specifying the mast adjustment to be provided enables the tractor designer to determine the minimum acceptable adjustment of the length of the top link in relation to the points of attachment of the linkage; it also permits the implement designer to determine the range of operating depths of the implement over which pitch adjustment can be obtained.

4) Dimensions are based on the assumption that the tractor manufacturer's normal wheel equipment is fitted.

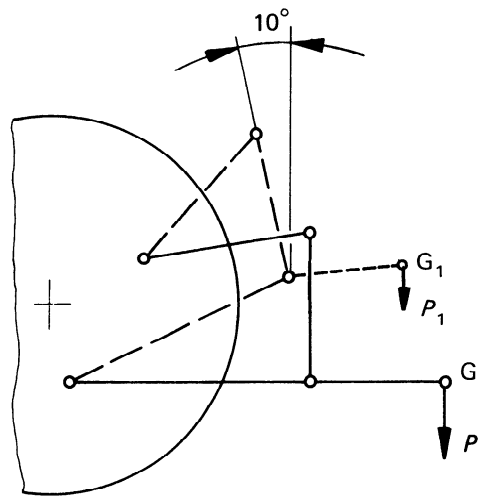

FIGURE 1 – Minimum angle between the vertical and the mast

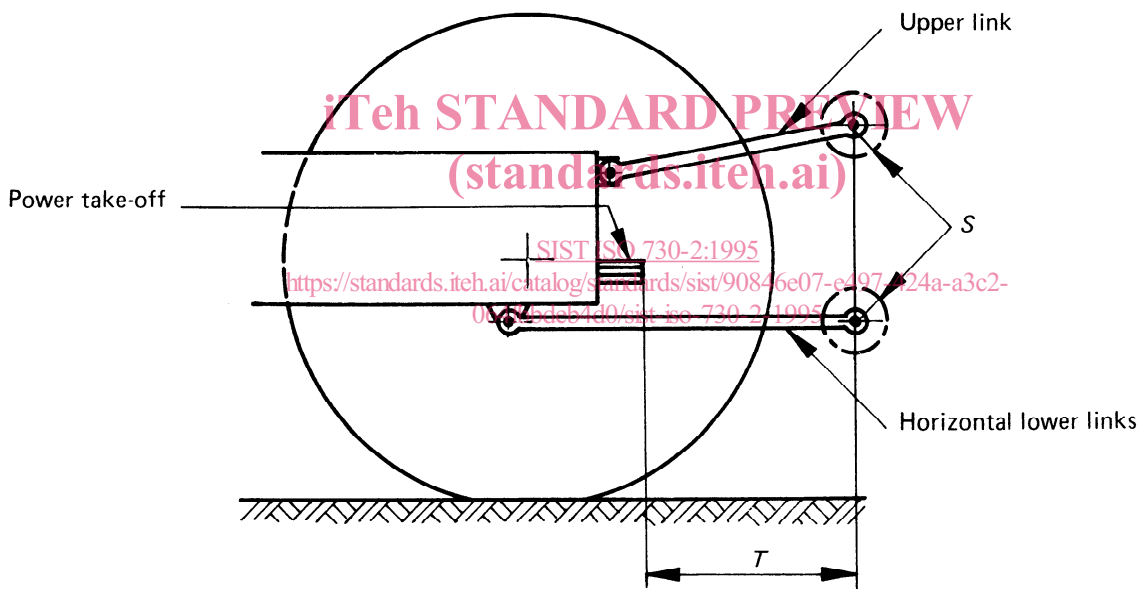
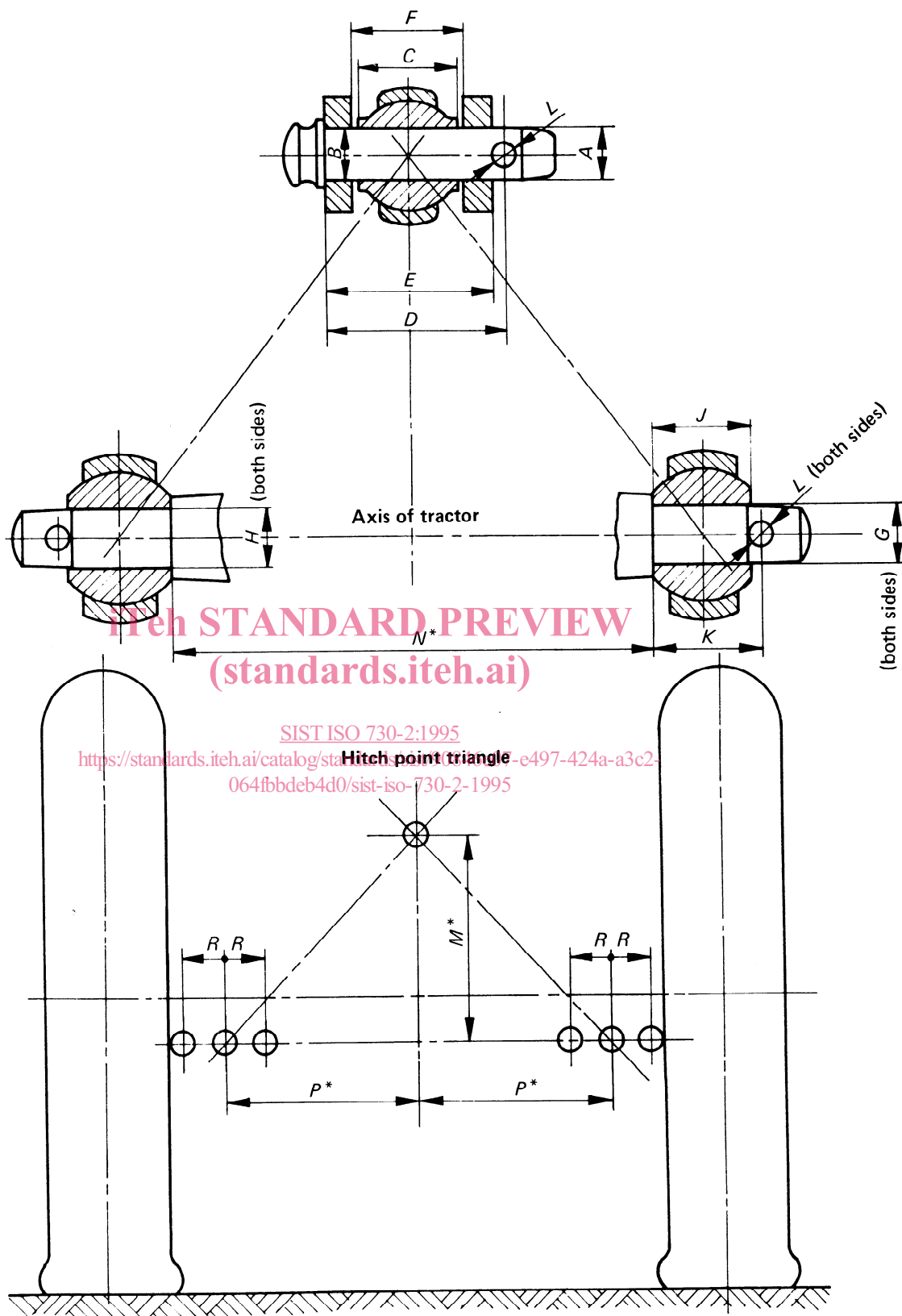

FIGURE 2 – Relation between power take-off and rear hitch points.  
Zones of clearance around hitch points

TABLE 1 – Dimensions concerning the zone around hitch points  
(see figure 2)

Dimensions in millimetres

| Dimension | Dimensional characteristics   | Category 1 N |      |
|-----------|---|--------------|------|
|           |   | min.         | max. |
| S         | Zone of clearance around each hitch point, spherical radius   | 45           | —    |
| T         | Distance from end of power take-off to centre of lower hitch point. Lower link in horizontal position | 300          | 375  |



STANDARD PREVIEW  
 (standards.iteh.ai)  
 SIST ISO 730-2:1995  
<https://standards.iteh.ai/catalog/standards/sist/064fbbdeb4d0/sist-iso-730-2-1995>  
 Hitch point triangle

\* Recommended dimensions. It may be necessary to vary these dimensions in the case of specialized implements.

FIGURE 3 – Dimensions concerning the hitch points

## ISO 730/II-1979 (E)

TABLE 2 – Dimensions concerning hitch points  
(see figure 3)

Dimensions in millimetres

| Dimension                 | Dimensional characteristics                                      | Category 1 N |       |
|---------------------------|--|--------------|-------|
|                           |  | min.         | max.  |
| <b>Upper hitch points</b> |  |              |       |
| <i>A</i>                  | Diameter of hitch pin  | 18,92        | 19    |
| <i>B</i>                  | Diameter of hitch pin hole                                       | 19,3         | 19,51 |
| <i>C</i>                  | Width of ball  | –            | 44    |
| <i>D</i>                  | Linch pin hole distance  | 76           | –     |
| <i>E</i>                  | Width between outer faces of yoke                                | –            | 69    |
| <i>F</i>                  | Width between inner faces of yoke                                | 44,5         | –     |
| <b>Lower hitch points</b> |  |              |       |
| <i>G</i>                  | Diameter of hitch pin  | 21,79        | 22    |
| <i>H</i>                  | Diameter of hitch pin hole                                       | 22,4         | 22,73 |
| <i>J</i>                  | Width of ball  | 34,8         | 35,0  |
| <i>K</i>                  | Linch pin hole distance*   | 39           | –     |
| <b>Linch pin hole</b>     |  |              |       |
| <i>L</i>                  | Diameter of linch pin hole for upper hitch pin                   | 12           | –     |
| <i>M</i>                  | Mass height  | 360** (min.) |       |
| <i>N</i>                  | Lower hitch point span   | 400 ± 1,5**  |       |
| <i>P</i>                  | Lateral distance from lower hitch point to centreline of tractor | 218**        |       |
| <i>R</i>                  | Lateral movement of lower hitch point                            | 50           | –     |

\* When lateral stays picking up on the lower hitch point holes are employed to limit side sway of the implement, the minimum dimension shall be 51 mm.

\*\* Recommended dimensions. It may be necessary to vary these dimensions in the case of specialized implements.

TABLE 3 – Lift, power lift and adjustment ranges

Dimensions in millimetres

| Reference in sub-clause 4.3 | Dimensional characteristics   | Category 1 N |
|-----------------------------|---|--------------|
| 14                          | Lower hitch points height   | 200 (max.)   |
| 15                          | Levelling adjustment range  | 75 (min.)    |
| 18                          | Power range   | 420 (min.)   |
| 19                          | Transport height (lower hitch point axis to be horizontal throughout) | 600 (min.)   |
| 20                          | Lower hitch point clearance   | 100 (min.)   |
| 21                          | Mast adjustment   |              |
|                             | Minimum height for highest position                                   | 420          |
|                             | Maximum height for lowest position                                    | 200          |

iTech STANDARD PREVIEW  
(standards.itech.ai)

SIST ISO 730-2:1995

<https://standards.itech.ai/catalog/standards/sist/90846e07-e497-424a-a3c2-664bbdb4d0/sist-iso-730-2-1995>