



Standard Test Methods for Relative Permittivity (Dielectric Constant) and Dissipation Factor by Fluid Displacement Procedures¹

This standard is issued under the fixed designation D1531; the number immediately following the designation indicates the year of original adoption or, in the case of revision, the year of last revision. A number in parentheses indicates the year of last reapproval. A superscript epsilon (ϵ) indicates an editorial change since the last revision or reapproval.

This standard has been approved for use by agencies of the Department of Defense.

1. Scope*

1.1 These test methods provide techniques for the determination of the relative (Note 1) permittivity and the dissipation factor of solid insulating materials by fluid (Note 2) displacement.

NOTE 1—In common usage, the word “relative” is frequently dropped.

NOTE 2—The word “fluid” is a commonly used synonym for “liquid” and yet a gas is also a fluid. In this standard, the word “fluid” is used to show that liquid is not all that is meant.

1.2 Test Method A is especially suited to the precise measurements on polyethylene sheeting at 23 °C and at frequencies between 1 kHz and 1 MHz. It may also be used at other frequencies² and temperatures to make measurements on other materials in sheet form.

1.3 Test Method B is limited to the frequency range of available guarded bridges. It is especially suited to measurements on very thin films since it does not require determination of the thickness of the specimen yet it provides an estimate of the thickness of thin films that is more accurate and precise than thickness measurements obtained by other means.

1.4 Test Method B is also useful for measurements of polymer sheeting up to 2-mm thickness.

1.5 These test methods permit calculation of the dissipation factor of the specimens tested.

1.6 The values stated in SI units are to be regarded as the standard.

1.7 *This standard does not purport to address all of the safety concerns, if any, associated with its use. It is the responsibility of the user of this standard to establish appropriate safety and health practices and determine the applica-*

bility of regulatory limitations prior to use. For a specific precautionary statement, see 7.2.

2. Referenced Documents

2.1 ASTM Standards:³

D150 Test Methods for AC Loss Characteristics and Permittivity (Dielectric Constant) of Solid Electrical Insulation

D374 Test Methods for Thickness of Solid Electrical Insulation

D831 Test Method for Gas Content of Cable and Capacitor Oils

D924 Test Method for Dissipation Factor (or Power Factor) and Relative Permittivity (Dielectric Constant) of Electrical Insulating Liquids

D1711 Terminology Relating to Electrical Insulation

D6054 Practice for Conditioning Electrical Insulating Materials for Testing

E1 Specification for ASTM Liquid-in-Glass Thermometers

2.2 ASTM Adjuncts:

Measuring cell (three drawings)⁴

3. Terminology

3.1 *Definitions*—Definitions are in accordance with Terminology D1711.

3.2 *Definitions of Terms Specific to This Standard:*

3.2.1 *compatibility, n*—fluid is considered compatible with a test specimen if, during the time required to complete a test of the specimen in the fluid at the specified temperature and frequency, the calculated permittivity of the specimen does not change by more than 0.1 % and the dissipation factor change is less than 0.0001.

4. Summary of Test Methods

4.1 *Test Method A: The Single-Fluid Technique*—Measurements are made with a fixed-plate, two-terminal,

¹ These test methods are under the jurisdiction of ASTM Committee D09 on Electrical and Electronic Insulating Materials and are the direct responsibility of Subcommittee D09.12 on Electrical Tests.

Current edition approved Oct. 1, 2006. Published October 2006. Originally approved in 1958. Last previous edition approved in 2001 as D1531 – 01^{ε1}. DOI: 10.1520/D1531-06.

² Coutlee, K. G., “Liquid Displacement Test Cell for Dielectric Constant and Dissipation Factor up to 100 Mc,” 1959 Annual Report, Conference on Electrical Insulation, National Research Council, Publication 756, Washington, DC.

³ For referenced ASTM standards, visit the ASTM website, www.astm.org, or contact ASTM Customer Service at service@astm.org. For *Annual Book of ASTM Standards* volume information, refer to the standard’s Document Summary page on the ASTM website.

⁴ Available from ASTM International Headquarters. Order Adjunct No. ADJD1531. Original adjunct produced in 1961.

*A Summary of Changes section appears at the end of this standard

self-shielded test cell assembly. By two measurements, one with the cell filled with the fluid (which in this case is a liquid) only and the second one with the solid specimen immersed in the liquid, a change in capacitance is determined. This capacitance difference is used with the approximate thickness of the specimen, the plate spacing, and the precisely known permittivity of the liquid to calculate the permittivity of the specimen. The dissipation factor of the test specimen is calculated from measurements of the cell with the liquid alone and with the specimen immersed in it. Precision and accuracy are enhanced by limiting the proportion of fluid to solid, limiting the difference in permittivity between the fluid and the solid, and designing the cell so that both the stray capacitance and the sensitivity limit of the measuring instrument are very small relative to that part of the capacitance caused by the specimen. Also, because of its bulk, the measuring system is insensitive to mechanical and thermal disturbances. Since it is not necessary to know the thickness of the specimen accurately and it is not necessary to apply electrodes, there is an overall saving in testing time.

4.2 *Test Method B*—This is a two-fluid technique that uses a rigidly constructed, fully shielded, temperature-controlled cell.

4.2.1 The fluids are:

4.2.1.1 Two liquids or

4.2.1.2 One liquid and a gas such as air or nitrogen.

4.2.2 Observations of capacitance and dissipation factor from the four following conditions are used to compute relative permittivity, dissipation factor, and the thickness of the specimen:

4.2.2.1 Without a solid specimen but with a single fluid in the cell,

4.2.2.2 Without a solid specimen but with a fluid different from that in 4.2.2.1,

4.2.2.3 With a solid specimen and with the single fluid of 4.2.2.1, and

4.2.2.4 With a solid specimen and with the different fluid of 4.2.2.2.

TEST METHOD A—LIQUID DISPLACEMENT METHOD USING A SINGLE FLUID

5. Significance and Use

5.1 *Permittivity:*

5.1.1 *Polyethylene and Materials of Permittivity Within 0.1 of That of Polyethylene*—Since the permittivity of benzene or 1-cSt silicone fluid is very close to that of polyethylene, these fluids are recommended for highly accurate and precise testing of polyethylene or other materials with permittivity close to that of polyethylene. These aspects of the test method make it a suitable tool to determine batch-to-batch uniformity of a polyethylene compound to meet precise requirements of high capacitance uniformity and capacitance stability in electronic apparatus. It also serves as a means to detect impurities, as well as changes resulting from prolonged exposure to high humidity, water immersion, weathering, aging, processing treatments, and exposure to radiation.

5.1.2 *Other Materials*—This test method provides advantages for routine testing of those materials that have a poorer

match in permittivity between the liquids mentioned in 5.1.1 and the specimen. These advantages include, but are not limited to, a reduction of the probability of errors caused by imprecise thickness data and the ease with which tests can be performed. Correction factors can be calculated to account for the bias introduced by the permittivity mismatch. The two liquids mentioned in 5.1.1 are not the only liquids having known values of dielectric properties and are known to be compatible with a solid electrical insulating material.

5.2 *Dissipation Factor*—Normally, polyethylene has a very low dissipation factor, and a test specimen exhibiting an abnormally high dissipation factor would be suspected of containing impurities or being contaminated. The reproducibility of dissipation factor by this test method is somewhat better than that obtainable with the more conventional methods, but is limited by the sensitivity of commercially available measuring apparatus.

6. Apparatus

6.1 *Measuring Circuits*—Any low-voltage bridge or resonant-circuit method conforming to the requirements of Test Methods D150 is suitable when the parallel substitution method is used. A capacitance sensitivity and readability of about 0.01 pF and a dissipation factor sensitivity and readability of at least 0.000 01 is needed. One means for obtaining this sensitivity at 100 kHz and above is by using commercially available resonant circuit apparatus and high Q coils (500 minimum).

6.2 *Leads and Connectors*—Low-loss coaxial connectors and leads are recommended for connecting the cell to bridges equipped with guard circuits for frequencies from 1000 Hz to 1 MHz. Terminate the guard as close as possible to the cell.

6.3 A rigid lead construction is necessary for connecting the cell to unguarded circuits including resonant circuits. Such construction stabilizes stray capacitance. Bare #10 AWG (2.5-mm diameter) copper is suitable if rigidly mounted and maintained in the same position throughout the tests. At frequencies of 1 MHz and higher, lead resistance and contact resistance become important because they affect dissipation factor measurements of 0.0001 or less. Contact resistance can be minimized by use of bright solid copper clips for connections. Such clips shall be small in size to minimize the effect that placement of the clip has on the measured capacitance. Take care to keep the variations in capacitance between leads and surrounding objects to less than 0.01 pF during measurements.

6.4 The measuring cell in which the test specimens are immersed in the liquid is shown in Fig. 1. It is a two-terminal, self-shielded-type cell consisting of a rectangular 6.35-mm (¼-in.) thick gold-plated brass center electrode having parallel and flat faces, each 58.06 cm² (9.00 in.²) in area. This electrode is supported by five polytetrafluoroethylene post insulators and is located midway between two gold-plated brass electrodes that form an integral part of the walls of the cell. The standard spacing between the plates is 1.52 ± 0.05 mm (0.060 ± 0.002 in.); however, other spacing may be used to accommodate test specimens of thicknesses other than 1.27 mm (0.050 in.), such

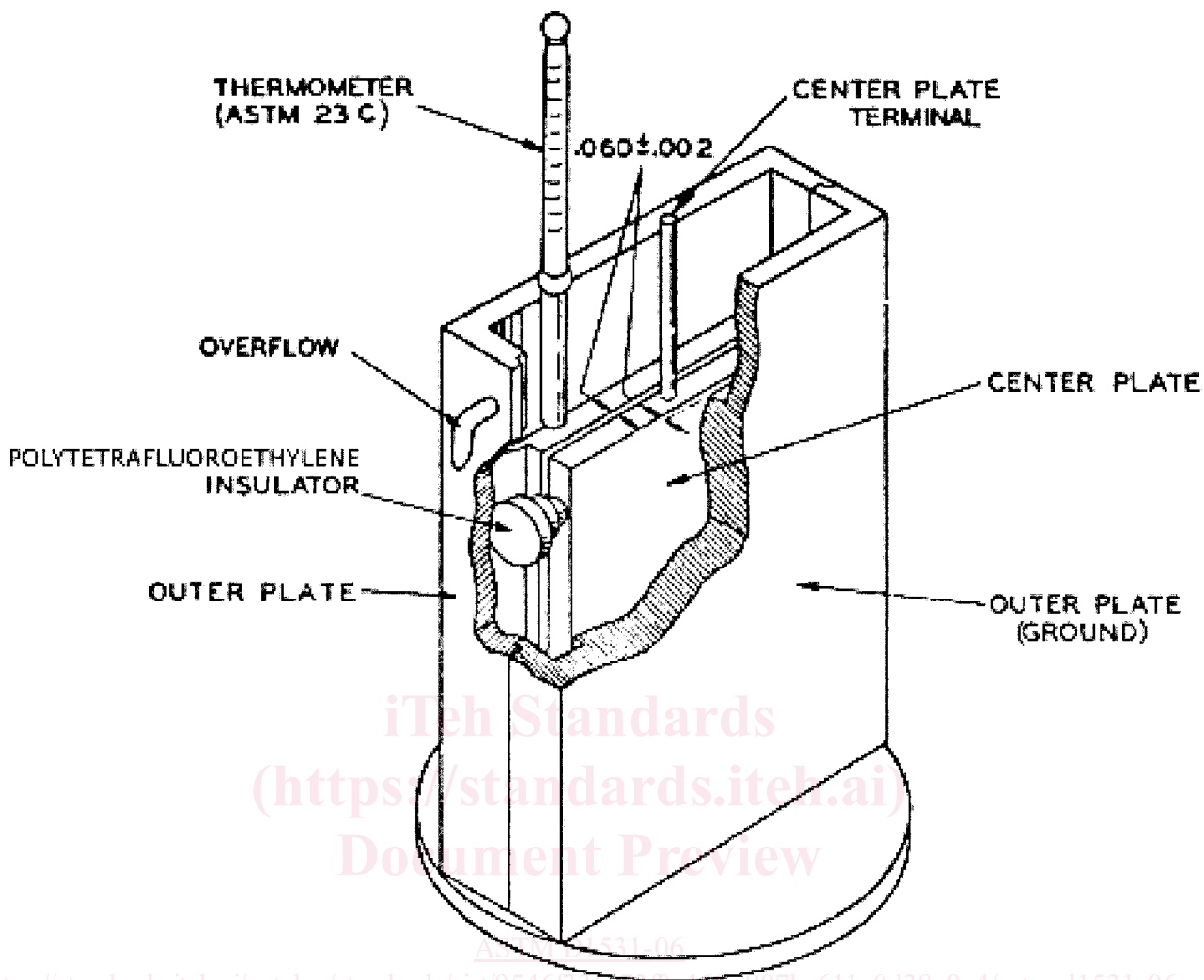

FIG. 1 Measuring Cell for Test Method A

Plate assembly shall be a sliding fit in the cell subassembly; if necessary, the polytetrafluoroethylene post insulators may be modified very slightly to accomplish this. The tolerances on the component parts have been apportioned so as to provide a spacing of 1.52 ± 0.05 mm (0.060 ± 0.002 in.).

as 1.6- and 3.2-mm ($1/16$ - and $1/8$ -in.) test specimens. The center electrode slides in grooves and can be removed readily to permit easy cleaning. The cell is equipped with an overflow pipe to maintain a constant level of the liquid with the test specimens either in or out. The cooling effect resulting from the evaporation of the liquid is small at the specified test temperature because of the large mass of metal and the small area of liquid exposed to the air, so that under normal testing conditions the required stability of capacitance and temperature can be obtained without the use of a cover.

6.5 *Thermometer*—An ASTM Engler viscosity thermometer having a range from 18 to 28 °C and conforming to the requirements for Thermometer 23 °C in Specification E1 can be used.

7. Standard Liquid Dielectrics

7.1 *Silicone Liquid*—Use a 1.0-cSt (1×10^{-6} m²/s) silicone fluid. Since the permittivity, at a fixed frequency, of this liquid changes with temperature, determine the exact value of each

lot of liquid using the three-terminal measuring cells and procedures of Test Method D924. The permittivity values of silicone liquid are quite similar to those of dry ACS grade benzene as shown in Table 1. The dissipation factor of 1.0-cSt silicone liquid is less than 0.000 005 from 100 kHz to 1 MHz and therefore can be considered zero over this frequency range. The liquid can be used a number of times or until an increase in dissipation factor is observed.

TABLE 1 Permittivity Values for Dry Benzene

Temperature, °C	Permittivity	Temperature, °C	Permittivity
21.8	2.2802	23.2	2.2775
22.0	2.2798	23.4	2.2771
22.2	2.2794	23.6	2.2768
22.4	2.2790	23.8	2.2764
22.6	2.2787	24.0	2.2760
22.8	2.2783	24.2	2.2756
23.0	2.2779	24.4	2.2752

7.2 *Benzene*—Use certified ACS reagent-grade (thiophene-free) benzene having a permittivity as specified in Table 1 as the referee liquid. As the permittivity of a liquid is a function of temperature, measure the temperature of the cell to an accuracy of ± 0.1 °C both with the test specimens in and out. The permittivity values shown in Table 1 are for benzene that has been dried over powdered calcium hydride for three months. U.S. commercial certified ACS reagent-grade benzene has been found generally satisfactory. However, in case of a dispute, dry the benzene as above or measure the permittivity of the benzene or both. The dissipation factor of the benzene shall not exceed 0.000 01 during test. From 100 kHz to 1 MHz, the dissipation factor of ACS reagent-grade benzene is consistently less than 0.000 005. The benzene can be used a number of times or until an increase in dissipation factor is observed. (**Warning**—Observe proper precautions because of the toxicity and flammability of benzene. Minimize benzene fumes from test specimens by dropping the specimens in a beaker and covering it at once. A portable hood placed near the cell will also remove benzene fumes.)

7.3 Other liquids have been used by many laboratories. Satisfactory liquids have permittivity that is known precisely to the fourth decimal place at the test frequency and is approximately the same as that of the specimen.

7.4 Avoid liquids that dissolve any constituents of the specimen, result in swelling of the specimen, or are absorbed within the body of the specimen.

7.5 Avoid liquids that exhibit peaks in dissipation factor in excess of 0.000 05 in the frequency range ± 50 % of the test frequency.

8. Sampling

8.1 Take samples according to the applicable material specification and observe the following precautions in handling:

8.1.1 Handle specimens with tweezers so that no fingerprints or other contamination is introduced onto the specimen. This precaution is very important for polyethylene and is expected to be very important for other materials also.

8.1.2 Note the handling precautions of Test Method B that relate to removing surface contamination and maintaining a clean surface between sampling and test, not only to improve precision, but also to keep the apparatus and the liquid(s) clean (see Section 18).

9. Test Specimens

9.1 Mold the sheets of the material to be tested to a thickness of 1.27 ± 0.12 mm (0.050 ± 0.005 in.) (see 9.3) and of sufficient size to cut two pieces 68.3 by 100 mm ($2\frac{11}{16}$ by $3\frac{15}{16}$ in.) from them. These two pieces constitute a test specimen, but in the following text, each piece is referred to as a test specimen. The number of tests required for each compound is as required by the material specification.

9.2 Test materials having thicknesses other than 1.27 mm (0.050 in.) by changing the thickness of the center electrode so that the test specimens occupy approximately 80 % of the gap. For referee tests, use a 1.27-mm (0.050-in.) specimen in a 1.52-mm (0.060-in.) gap.

9.3 Measure the thickness of each test specimen to the nearest 0.025 mm (0.001 in.) in accordance with Method A or C of Test Methods D374. Use the average of five thickness determinations along the diagonals of the specimen, one near the center and one near each end in calculating the permittivity. Measure the specimen under the same atmospheric conditions as described in 10.1.

10. Conditioning

10.1 Unless otherwise specified, condition the test specimens for 40 h in the Standard Laboratory Atmosphere of 50 ± 5 % relative humidity and 23 ± 2 °C as described in Procedure A of Practice D6054. Store the liquid container and test cell in the Standard Laboratory Atmosphere for a sufficient length of time for the temperature to equilibrate. To obtain the optimum degree of accuracy, the temperature of both the liquid and the specimen shall be equal.

10.2 If the effects of other environmental conditions are to be explored, such as exposure to high humidity, water immersion, weathering, or other treatments, measure the test specimens as soon as practicable after removal from the particular environmental condition, allowing only sufficient time for the test specimens to come to equilibrium with the temperature of the liquid and the test cell.

10.3 If tests are made at a temperature other than 23.0 °C, a correction for the temperature coefficient of permittivity of the polymer compound may be necessary.

11. Procedure

11.1 *Air Capacitance and Dissipation Factor of Cell Without Specimen*—It is not necessary to measure the actual air capacitance and dissipation factor of the empty cell in the procedure to determine the permittivity of the polyethylene test specimens. However, from the standpoint of contamination or capacitance stability, the empty cell data are of interest. Prepare a new empty test cell for use by rinsing the cell several times with warm distilled water followed by a few rinsings with acetone and then with benzene. Dry in air at approximately 50 °C for about 1 h. After cooling the cell to room temperature, a suitable cell will have a dissipation factor of less than 0.000 01.

11.2 *Capacitance and Dissipation Factor of Cell Containing Liquid Only:*

11.2.1 Fill the cell slowly with liquid, about 50 mL, either directly from the original bottle or from a chemically clean glass container equipped with a small glass tube, such as a wash-water bottle equipped with a rubber bulb. Fill the cell until a small quantity flows out of the overflow tube into a catch bottle.

11.2.2 Balance or tune the test circuit and record the total capacitance, C_T , in the bridge arm or resonant circuit. Then connect the grounded lead from the measuring circuit to any convenient location on the metal case of the cell. Locate the ungrounded lead so that it is about 25 mm above the center terminal of the cell. This lead shall descend from a vertical direction to maintain maximum clearance from all surrounding parts, including the thermometer. If coaxial leads and connectors are used, disconnect them at the cell end. Balance or tune the test circuit and record the capacitance, C_0 . Also record

readings of the conductance, G_0 , the quality factor, Q_0 , or the dissipation factor, D_0 .

11.2.3 Attach the ungrounded lead by moving it downward to the center terminal, or plug in the coaxial connector, and rebalance or retune the test circuit. Then determine the capacitance, C_p , of the cell containing liquid alone and the dissipation factor, D_p , of the liquid. Specifically, record readings of measuring circuit capacitance, C_1 , and conductance, G_1 , quality factor, Q_1 , or dissipation factor, D_1 , for use in calculation of C_l and D_l by equations given in 12.2.1. Normally, at frequencies from about 100 kHz to 1 MHz, the value obtained for D_l will be only an apparent value rather than the true value because of lead and contact resistances.

11.3 *Capacitance and Dissipation Factor of Cell Containing Liquid and Specimen*—Without disturbing the position of the ungrounded lead still connected to the center terminal, carefully insert the two test specimens between the plates of the test cell using clean metal tweezers. Except as provided for in Section 7, discard the liquid that flows out through the overflow tube as the test specimens are inserted. Rebalance or retune the test circuit and determine the capacitance, C_c , and the dissipation factor, D_c , of the cell containing the combination of test specimens and liquid. Specifically, record readings of measuring circuit capacitance, C_2 , and conductance, G_2 , quality factor, Q_2 , or dissipation factor, D_2 , for use in calculation of C_c and D_c by equations given in 12.2.1. If possible, observe directly and record the change of capacitance, ΔC , of the test cell resulting from introduction of the test specimens. Note that ΔC is positive if the cell capacitance was increased, or negative if the cell capacitance was decreased by insertion of the test specimens.

11.4 Remove the test specimens from the cell promptly to prevent excessive swelling.

11.5 If other test specimens are to be tested immediately, add liquid until a small amount overflows and proceed to test as in 11.2 and 11.3.

11.6 Since the liquid is constantly being replenished by such a procedure, it may be used until the capacitance at any given temperature increases by 0.1 pF or until its dissipation factor exceeds 0.00001. Empty the cell and refill it with new liquid after testing moist or contaminated specimens.

12. Calculation

12.1 *Permittivity*—Calculate the permittivity as follows:

$$K_p = K_l + \Delta C (t_a/t_s) \times (1/C_v) \quad (1)$$

If $(K_p - K_l)$ is greater than ± 0.1 , use the following equation:

$$K_p = K_l + \frac{\Delta C}{C_v \times (t_s/t_a) - \frac{\Delta C(1 - t_s/t_a)}{K_l}} \quad (2)$$

where:

- C_v = $2 \times (0.008\ 854\ 2\ A/t_a)$ pF,
- K_p = permittivity of specimens,
- K_l = permittivity of liquid at test temperature,

ΔC = $(C_2 - C_1)$ = change of capacitance in picofarads when the specimens are inserted (ΔC is positive if the cell capacitance increases, negative if the cell capacitance decreases),

- A = area of center capacitor plate, mm² (one face),
- t_a = average separation of capacitor plates, mm, and
- t_s = average thickness of the two test specimens, mm.

12.2 *Dissipation Factor*—Calculate the dissipation factor as follows:

$$D_p = D_l + (D_c - D_l)(t_a/t_s) \quad (3)$$

which, in cases in which D_l is assumed to be zero, simplifies to:

$$D_p = D_c (t_a/t_s) \quad (4)$$

where:

- D_p = dissipation factor of specimens,
- D_l = dissipation factor of liquid, and
- D_c = dissipation factor of combination of specimens and liquid.

12.2.1 Calculate D_l and D_c by one of the following equations, except that at frequencies from about 100 kHz to 1 MHz, change G_0 to G_1 , Q_0 to Q_1 , and D_0 to D_1 , in the equations for D_c only:

Eq 5 when the measuring circuit is a direct-reading conductance meter or bridge,

Eq 6 for a resonance-rise (Q meter) circuit, or

Eq 7 for a direct-reading dissipation factor bridge:

$$D_l = (G_1 - G_0)/\omega C_1 \quad (5)$$

$$D_c = (G_2 - G_0)/\omega C_c$$

$$D_l = C_T(Q_0 - Q_1)/C_l Q_0 Q_1 \quad (6)$$

$$D_c = C_T(Q_0 - Q_2)/C_c Q_0 Q_2$$

$$D_l = C_T(D_1 - D_0)/C_l \quad (7)$$

$$D_c = C_T(D_2 - D_0)/C_c$$

where:

- G_0 = conductance reading, in picosiemens, of the measuring circuit at balance, before connection of the ungrounded lead to the cell terminal (see 11.2),
- G_1 = conductance reading, in picosiemens, of the measuring circuit at balance, after connection of the cell with liquid alone (see 11.2),
- G_2 = conductance reading, in picosiemens, of the measuring circuit at balance, after insertion of test specimens (see 11.3),
- ω = 2π times the frequency in Hz,
- C_l = $(C_0 - C_l)$ = capacitance, pF, of the test cell with liquid alone (see 11.2),
- C_c = $(K_l C_v + \Delta C)$, or $K_l C_v$ when ΔC is less than 0.5 pF = effective capacitance of the cell with test specimens and liquid,
- C_0 = capacitance reading, pF, of the measuring circuit at balance, after attachment of leads to the circuit terminals but before connection of the ungrounded lead to the cell terminal (see 11.2),

- C_1 = capacitance reading, pF, of the measuring circuit at balance, after connection of the ungrounded lead to the terminal of the cell containing liquid alone (see 11.2),
- C_2 = capacitance reading, pF, of the measuring circuit at balance, after insertion of test specimens (see 11.3),
- C_T = total capacitance, pF, in the measuring circuit or bridge arm at initial balance, before connection of leads to the measuring circuit terminals (see 11.2),
- Q_0 = quality factor of the measuring circuit at resonance before connection of the ungrounded lead to the cell terminal (see 11.2),
- Q_1 = quality factor of the measuring circuit at resonance after connection of the ungrounded lead to the terminal of the cell containing liquid alone (see 11.2),
- Q_2 = quality factor of the measuring circuit at resonance, after insertion of test specimens (see 11.3),
- D_0 = dissipation factor reading of the measuring circuit at balance, before connection of the ungrounded lead to the cell terminal (see 11.2),
- D_1 = dissipation factor reading of the measuring circuit at balance, after connection of the ungrounded lead to the terminal of the cell containing liquid alone (see 11.2), and
- D_2 = dissipation factor reading of the measuring circuit at balance, after insertion of test specimens (see 11.3).

13. Report

13.1 Report the following information:

- 13.1.1 Identification of the polyethylene compound or other material tested,
- 13.1.2 Frequency and temperature at which each test was made,
- 13.1.3 Permittivity and dissipation factor of each pair of test specimens tested,
- 13.1.4 Test apparatus used, and
- 13.1.5 Liquid used and its permittivity and dissipation factor.

14. Precision and Bias

14.1 The information in 14.2 and 14.3 relates to data obtained with polyethylene.

14.2 *Permittivity*—This test method is capable of providing a very high precision measurement. The repeatability is such that when two consecutive measurements are made under identical conditions on the same test specimens, the two values obtained normally do not differ from each other by more than ± 0.001 ($\pm 0.05\%$). Likewise, when two tests are made on two different sets of test specimens from the same molded sheet, the precision usually is much the same as in the first case. Interlaboratory tests have shown that the reproducibility at the same test frequency and temperature using different testing equipment and different supplies of benzene on the same molded sheets is expected to be within ± 0.002 ($\pm 0.10\%$).

14.3 *Dissipation Factor*—Under the same conditions as stated for permittivity, the expected repeatability for dissipation factor is such that values obtained for remeasured and duplicate samples are expected to be closer than $\pm 0.000\ 05$.

Under the conditions described, the reproducibility of the dissipation factor values of interlaboratory tests are not expected to differ by more than ± 0.0001 from the mean in the vicinity of 0.0001. In general, the dissipation factor precision stated above can be improved five to tenfold by use of the most sensitive testing apparatus available.

14.4 When the permittivity of the specimen is close to that of the fluid, the bias is expected to be extremely low, since the permittivity of the reference material (benzene) is precisely known.

TEST METHOD B—FLUID DISPLACEMENT METHOD USING TWO FLUIDS

15. Significance and Use

15.1 The use of this test method provides capacitance values from which relative permittivity is calculated with a greater precision than from other methods which require a precise knowledge of the thickness of the test specimen. This is of benefit when testing very thin films in the order of 2 to 10 μm since the thickness of such films is not easily measured with high precision.

15.2 This test method is applicable for research purposes, for quality control, and purchase specifications.

15.3 Dissipation factor and permittivity obtained by other techniques require precise dimensional information relating to electrode placement, flatness, parallelism, distance of separation, and so on. This test method does not require such precise data.

15.4 Test Method B, unlike Test Method A, provides reliable permittivity values when used with a fluid having permittivity that is not closely matched to the permittivity of the specimen.

15.5 This test method can provide a reference value of permittivity ($K(\text{ref})$) for the test specimen at a specific test temperature ($T(\text{ref})$) and specific frequency ($f(\text{ref})$). The effects of various parameters (such as voltage, pressure, humidity, and exposure) can be studied using other electrode systems as may be appropriate or convenient. The measured effects of these parameters on the capacitance can be used to calculate the changes in permittivity resulting from these effects. For example, the ratio of the capacitance at a selected test condition to the capacitance at the reference conditions multiplied by ($K(\text{ref})$) provides a permittivity value for the selected test condition which is often more precise than that obtained by other techniques. This also reduces the testing time to obtain such information.

15.6 For supplemental information on significance of permittivity and dissipation factor, see Test Methods D150.

16. Apparatus

16.1 *Bridge*—Use any low-voltage completely shielded capacitance and dissipation factor bridge conforming to the requirements of Test Methods D150. Transformer ratio-arm bridges are recommended because of the simplicity afforded by the grounded guard. The precision obtained depends upon the capacitance resolution (see Note 3) of the bridge. Readability