



Designation: D 5262 – 06

Standard Test Method for Evaluating the Unconfined Tension Creep and Creep Rupture Behavior of Geosynthetics¹

This standard is issued under the fixed designation D 5262; the number immediately following the designation indicates the year of original adoption or, in the case of revision, the year of last revision. A number in parentheses indicates the year of last reappraisal. A superscript epsilon (ϵ) indicates an editorial change since the last revision or reappraisal.

1. Scope

1.1 This test method is intended for use in determining the unconfined tension creep and creep rupture behavior of geosynthetics at constant temperature when subjected to a sustained tensile loading. This test method is applicable to all geosynthetics.

1.2 The test method measures total elongation of the geosynthetic test specimen, from the time of loading, while being maintained at a constant temperature. It includes procedures for measuring the tension creep and creep rupture behavior at constant temperature of conditioned geosynthetics as well as directions for calculating tension creep and creep rupture curves.

1.3 The values stated in SI units are to be regarded as the standard. The values given in parentheses are for information only.

1.4 *This standard does not purport to address all of the safety concerns, if any, associated with its use. It is the responsibility of the user of this standard to establish appropriate safety and health practices and determine the applicability of regulatory limitations prior to use.*

2. Referenced Documents

2.1 *ASTM Standards:*²

D 123 Terminology Relating to Textiles

D 1776 Practice for Conditioning and Testing Textiles

D 4439 Terminology for Geosynthetics

D 4491 Test Methods for Water Permeability of Geotextiles by Permittivity

D 4595 Test Method for Tensile Properties of Geotextiles by the Wide-Width Strip Method

E 6 Terminology Relating to Methods of Mechanical Testing

3. Terminology

3.1 *Definitions*—For definitions of many terms used in this test method, refer to Terminologies **D 123**, **D 4439** and **E 6**.

3.2 *Definitions of Terms Specific to This Standard:*

3.2.1 *atmosphere for testing geosynthetics, n*—air maintained at a relative humidity between 50 and 70 % and the test (Section 10.2).

3.2.2 *creep, n*—the time-dependent increase in accumulative strain in a material resulting from an applied constant force.

3.2.3 *design load, n*—the load at which the geosynthetic is required to operate in order to perform its intended function.

3.2.4 *failure, n*—an arbitrary point at which a material ceases to be functionally capable of its intended use.

3.2.5 *geogrid, n*—a geosynthetic formed by a regular network of integrally connected elements with apertures greater than 6.35 mm (1/4 in.) to allow interlocking with surrounding soil, rock, earth, and other surrounding materials to function primarily as reinforcement.

3.2.6 *geomembrane, n*—an essentially impermeable geosynthetic composed of one or more synthetic sheets.

3.2.6.1 *Discussion*—In geotechnical engineering, essentially impermeable means that no measurable liquid flows through a geosynthetic when tested in accordance with Test Methods **D 4491**.

3.2.7 *geosynthetic, n*—a planar product manufactured from polymeric material used with soil, rock, earth, or other geotechnical engineering-related material as an integral part of a man-made project, structure, or system.

3.2.8 *geotextile, n*—a permeable geosynthetic comprised solely of textiles.

3.2.8.1 *Discussion*—Current manufacturing techniques produce nonwoven fabrics, knitted (non-tubular) fabrics, and woven fabrics.

¹ This test method is under the jurisdiction of ASTM Committee D35 on Geosynthetics and is the direct responsibility of Subcommittee D35.02 on Endurance Properties.

Current edition approved August 1, 2006. Published November 2006. Originally approved in 1992. Last previous edition approved in 2004 as D 5262 – 04.

² For referenced ASTM standards, visit the ASTM website, www.astm.org, or contact ASTM Customer Service at service@astm.org. For *Annual Book of ASTM Standards* volume information, refer to the standards' Document Summary page on the ASTM website.

3.2.9 *index test, n*—a test procedure that may contain a known bias, but that may be used to establish an order for a set of specimens with respect to the property being measured.

3.2.10 *rate of creep, n*—the slope of the creep-time curve at a given time.

3.2.11 *tensile creep rupture strength, $[FL^{-1}]$, n*—for geosynthetics, the force per unit width that will produce failure by rupture in a creep test in a given time, at a specified constant environment.

3.2.12 *tensile creep strain, n*—the total strain at any given time.

3.2.13 *wide strip tensile test, n*—for geosynthetics, a tensile test in which the entire width of a 200-mm (8.0 in.)-wide specimen is gripped in the clamps with a gage length of 100 mm (4.0 in.).

4. Summary of Test Method

4.1 The tension creep and creep rupture behavior of geosynthetics is measured by applying a sustained load in one step and measuring the total elongation of the test specimen as a function of time while maintaining a specified temperature and humidity.

5. Significance and Use

5.1 This test method is developed for use in the determination of anticipated total elongation or time to rupture that may occur in geosynthetics under sustained loading conditions.

5.1.1 The test data can be used in conjunction with interpretive methods to evaluate creep strain potential at design loads.

5.1.2 The test data can be used in conjunction with interpretive methods to evaluate creep rupture potential at various loads.

5.2 This test method is not intended for routine acceptance testing of geosynthetics. This test method should be used to characterize geosynthetics intended for use in applications in which creep or creep rupture is of concern. The plane strain or rupture condition imposed during testing must be considered when using the test results for design.

5.3 The basic distinctions between this test method and other test methods for measuring tension creep and creep rupture behavior are (1) the width of the specimens (Section 8) and (2) the measurement of total elongation or time to rupture from the moment of specimen loading. The greater widths of the specimens specified in this test method minimize the contraction edge effect (necking) that occurs in many geosynthetic materials and provides a closer relationship to actual material behavior in plane strain tension conditions.

5.4 The creep or stress rupture of a given geosynthetic is likely to be reduced in soil because of load transfer to the soil. The unconfined environment represents a controlled test, in which the results are conservative with regard to the behavior of the material in service. Confined or in-soil testing may model the field behavior of the geosynthetic more accurately.

6. Apparatus

6.1 Clamps:

6.1.1 Clamps should be at least as wide as the specimen, with appropriate clamping power that will prevent slipping or

damage of the test specimen within or at the faces of the clamps. The clamps and clamping technique shall be designed to minimize eccentric loading of the specimen. A swivel or universal joint shall be used on one of the clamps at the end of the specimen. It is recommended that clamps permit the final centering of the specimen prior to application of the load.³

6.1.2 *Geotextiles and Geomembranes*—Each clamp shall be sufficiently wide to grip the entire width of the specimen, 200 mm (8.0 in.), and a minimum of 50-mm (2.0-in.) length in the direction of the applied force.

6.1.3 *Geogrids*—These should be clamped to assure complete tension load transfer through test direction members. The type of clamp and load transfer mechanism should be detailed in the test report. Roller grips or low melting point alloy with adequate strength may be used to assist proper clamping.

6.1.4 *Other Related Products*—Where special clamps are used to grip these products, they should conform to the general requirements for clamps used to grip geotextiles, geomembranes, and geogrids, and the clamping methods used should always be detailed in the report.

6.2 *Loading System*—The loading system must be designed so that the load applied and maintained on the specimen is within $\pm 1\%$ of the desired load. Loads may be applied by weights, weights and fulcrums, or pneumatics. The loading mechanism must permit reproducibly rapid and smooth loading, as specified in 11.4. No dynamic forces on placement of the loads shall be allowed. Provision must also be made to ensure that shock loading, caused by specimen failure, is not transferred to other specimens undergoing testing.³

6.3 *Extension Measurement*—Extensometers are preferred for the measurement of elongation in geosynthetics. Whenever possible, other means of measuring elongation should be calibrated against extensometers. In any case, the device chosen shall be capable of measuring deformations to an accuracy of at least $0.003 \pm \text{mm}$ ($0.0001 \pm \text{in.}$). The means of measuring elongation should be indicated clearly in the report.

6.4 *Vibration Control*—Creep and creep rupture tests are sensitive to shock and vibration. The location of the apparatus, test equipment, and mounting shall be designed so that the specimen is isolated from vibration. Multi-station test equipment must be of sufficient rigidity so that no significant deflection due to shock or vibration occurs during testing.

6.5 *Time Measurement*—The accuracy of the time measuring device shall be $\pm 1\%$ of the elapsed time of each creep or creep rupture measurement load increment.

6.6 *Temperature Control and Measurement:*

6.6.1 The temperature in the test space, especially close to the gage length of the specimen, shall be maintained within $\pm 2.0^\circ\text{C}$ ($\pm 3.6^\circ\text{F}$) of the targeted value by a suitable automatic device and shall be stated in the report. It is generally recognized that thermal contraction and expansion, associated with small temperature changes during the test, may produce changes in the apparent creep rate, especially near the transition temperature.

³ Examples of clamping, loading, and extensometer systems that have been used successfully are found in the appendixes.

6.6.2 Temperature measurements shall be recorded at frequent intervals, or recorded continuously, in order to ensure an accurate determination of the average test temperature and compliance with 6.6.1.

6.7 Environmental Control and Measurement:

6.7.1 When the test environment is air, the relative humidity shall be maintained between 50 and 70 % unless the creep or creep rupture behavior of the geosynthetic has been shown to be unaffected by humidity. The relative humidity shall be recorded at frequent intervals to ensure that an accurate determination of the average test humidity can be made.

6.7.2 The test environment shall be maintained constant throughout the test. Safety precautions should be taken to avoid personal contact during the test. The area should be isolated adequately and fenced such that only the test operator has access to the test station.

7. Sampling

7.1 *Laboratory Sample*—For the laboratory sample, take a full-width swatch at least 1-m (40-in.) long in the machine direction from each roll in the lot sample. The sample may be taken from the end portion of a roll, provided there is no evidence that it is different from other portions of the roll.

7.2 Test Specimens:

7.2.1 *Geotextiles and Geomembranes*—For tests in the machine and cross-machine directions, respectively, take from each sample the number of specimens as directed in 9.1. Take the specimens from a diagonal on the sample, with no specimens closer than $\frac{1}{10}$ the width of the roll or 150 mm (6 in.), whichever is smaller. For geomembranes, exercise care in selecting, cutting, and preparing the specimens to avoid nicks, tears, scratches, folds, or other imperfections that are likely to cause premature failure.

NOTE 1—Nonreinforced geomembranes are extremely sensitive in this regard.

7.2.2 *Geogrids and Other Related Products*—For tests in the machine and cross-machine directions, respectively, take from each sample the number of specimens as directed in 9.1. Take the specimens at random from the laboratory sample. For measurement of machine direction properties, take specimens from different positions across the width of the sample. For the measurement of cross-machine direction properties, take specimens from different positions along the length of the sample. Take no specimens nearer to the edge than $\frac{1}{10}$ the width of the roll or 150 mm (6 in.), whichever is smaller.

8. Test Specimen

8.1 *Geosynthetics*—Prepare each finished specimen to 200–mm (8.0–in.) wide by at least 200–mm (8.0–in.) long, with the length dimension being designated and accurately parallel to the direction that the creep or creep rupture behavior is being measured.

8.1.1 *Geotextiles*—Prepare specimen width to 200 mm (8.0 in) wide by at least 200 mm (8.0 in) long.

8.1.2 *Geogrids*—Prepare specimen width to include at least three longitudinal elements abreast parallel to the direction that the creep or creep rupture behavior is being measured with

each element long enough to include at least three apertures, as illustrated in Fig. X2.1.

8.2 The length of the specimen depends on the type of clamps being used. The specimen must be long enough to extend through the full length of both clamps, as determined for the direction of the test.

8.3 When specimen integrity is not affected, the specimen may be cut initially to the finished width.

8.4 This test method may not be suitable for some woven geotextiles or geogrids that exhibit breaking strengths in excess of 100 kN/m (570 lbf/in.), due to clamping and equipment limitations.

9. Number of Tests

9.1 Unless otherwise agreed upon, creep and creep rupture tests shall be conducted at load levels as specified by the designer. Four load levels are recommended for characterization of the material. Loads shall be selected at intervals of approximately 10 % of the maximum load per unit width as determined by applicable ASTM test methods.

9.1.1 For creep test, the loads should be 20, 30, 40, 50 and 60 % of the ultimate tensile strength of the sample being tested, unless otherwise agreed upon by the parties involved.

9.1.2 For creep rupture tests, the loads should be 50, 60, 70, 80, and 90 % of the ultimate tensile strength of the sample being tested, unless otherwise agreed upon by the parties involved.

NOTE 2—It is generally recognized that characterization involves identification of the load levels at which there is no creep (no increase in strain with the log of time), low to moderate creep (linear increase in strain with the log of time), and high creep (exponential increase in strain with the log of time).

9.2 To evaluate design creep strains, it is recommended that a minimum of two creep tests be performed for each test temperature (that is, one at the design load and one at a load that exceeds the design load, as specified by the designer).

9.3 To evaluate creep rupture, it is recommended that a minimum of four creep rupture tests be performed for each test temperature to sufficiently characterize the creep rupture curve.

NOTE 3—For each temperature, the four tests should be at different load levels.

10. Conditioning and Testing Atmosphere

10.1 Bring the specimens to moisture equilibrium in the atmosphere for testing geosynthetics. Equilibrium is considered to have been reached when the increase in mass of the specimen, in successive weighings made at intervals of not less than 2 h, does not exceed 0.1 % of the specimen mass. In general practice, the industry approaches equilibrium from the as-received side.

NOTE 4—It is customary that geosynthetic materials are frequently not weighed to determine when moisture equilibrium has been reached. While such a procedure cannot be accepted in cases of dispute, in routine testing, it may be sufficient to expose the material to the standard atmosphere for testing for a reasonable time period before the specimens are tested. A time period of 24 h has been found acceptable in most cases. However, certain fibers may exhibit slow moisture equilibrium rates from the

as-received wet side. When this is known, a preconditioning cycle, as prescribed in Practice D 1776, may be agreed upon between contractual parties.

10.2 To characterize the influence of temperature, in addition to the standard temperature of $20 \pm 2.0^\circ\text{C}$ ($68 \pm 3.6^\circ\text{F}$), two or more additional temperatures should be used to cover the useful temperature range of the geosynthetic considered. These should be chosen in suitable increments reflecting the variation of creep and creep rupture of the geosynthetic with temperature and phase transitions of the material. The test temperature will generally be determined by site conditions and should be agreed upon by contractual parties. Suggested additional temperatures are $10 \pm 2.0^\circ\text{C}$ ($50 \pm 3.6^\circ\text{F}$), $30 \pm 2.0^\circ\text{C}$ ($86 \pm 3.6^\circ\text{F}$), $40 \pm 2.0^\circ\text{C}$ ($104 \pm 3.6^\circ\text{F}$), $50 \pm 2.0^\circ\text{C}$ ($122 \pm 3.6^\circ\text{F}$), and $60 \pm 2.0^\circ\text{C}$ ($140 \pm 3.6^\circ\text{F}$).

11. Procedure

11.1 Test adequately conditioned specimens. Conduct the tests at the temperature(s) selected in 10.2 and relative humidity of 50 to 75 % (see 6.7.1). Contractual parties may specify an additional temperature(s) based on expected service conditions for the installation.

11.2 Mount the specimen centrally in the clamps. The specimen length in the machine direction and cross machine direction tests, respectively, must be parallel to the direction of application of force.

11.3 Attach the extension measuring devices directly to the specimen. If these are optical devices, set up the measurement mechanism accordingly. Make the initial or reference measurement.

11.3.1 It is recommended that the initial gage length be set at 75 mm (3 in.) for geotextiles and geomembranes.

11.3.2 The gauge length for geogrids should be the distance, in the machine direction, across two consecutive apertures including the three nodes

11.4 Where required, place a pretension force, which includes any load due to the mass of the clamps, rapidly and smoothly on the specimen. In any case, the total time between placement of a pretension load and full load shall not exceed 10 min. Record the pretension force and resulting extension. It is generally accepted that the application of a pretension force is required when testing certain geosynthetics, for which part of the extension on loading occurs from a realignment of fiber structure and is relatively variable, while the subsequent time-dependent elongation, which is due to creep of the fibers, is more consistent. The application of a pretension force has therefore been selected as a simple means of establishing zero strain.

11.5 The pretension force, which includes the weight of the loading mechanism and weight of grip, should have a maximum total applied force on the specimen of 45 N (10 lbf) for materials exhibiting a breaking force of 17 500 N/m (100 lbf/in.) and under, as determined in accordance with Test Method D 4595. For materials exhibiting a breaking force in excess of 17 500 N/m (100 lbf/in.), a pretension force equal to 1.25 % of the expected breaking force should be applied; however, in no case should the total pretension force exceed 300 N (67.5 lbf).

11.6 Apply the full load rapidly and smoothly to the specimen, preferably at a strain rate of $10 \pm 3 \%$ /min. Record the total time for loading (excluding pretension). In any event, disregard measurements within five times of the loading time.

11.7 Measure the extension of the specimen in accordance with the following approximate time schedule: 1, 2, 6, 10, and 30 min; and 1, 2, 5, 10, 30, 100, 200, 500, and 1000 h. For creep tests longer than 1000 h, measure and record extension every 500 h until testing is complete.

NOTE 5—In design, it is generally accepted that creep or creep rupture data should not be extrapolated beyond one order of magnitude. In many cases, a test period of 1000 h therefore, may not reflect the long-term behavior of the material accurately. For such cases, tests should be conducted for a minimum of 10 000 h.

NOTE 6—For preliminary evaluation of newly developed products when testing is underway but has not yet reached 10 000 h, creep or creep rupture behavior may be inferred from completed test results on essentially identical products from the same family of products; (that is, manufactured by the same organization using the same process technology, polymer type, polymer structure, polymer molecular weight, polymer additives, constituent materials, product configuration, etc.). Application of this inference is appropriate only when a minimum of 1000 h of testing is completed on the new product and a definable correlation exists with the available 10 000 h test results for the family of products which bound the ultimate strength and constant load level for creep or creep rupture testing of the new product.

11.8 Readings should be recorded more frequently if discontinuities in the creep strain versus log of time plot are suspected or encountered. To avoid such discontinuities, the use of automatic monitoring and measuring equipment is recommended.

11.9 Terminate a test when the specimen ruptures or at the end of the agreed upon period. If the specimen ruptures, report the type of failure, location, and time to failure.

12. Calculation

12.1 Creep Curves—The standard curve is a graph of strain versus log of time, as shown in Fig. 1. The data are prepared by use of the following calculations:

12.1.1 Time—Elapsed time intervals are converted to hours and converted to the log of time (in hours).

12.1.2 Strain—The percent strain at each interval is calculated (to the nearest 0.1 mm) using Eq 1:

$$\epsilon = (\Delta L \times 100) / L_g \tag{1}$$

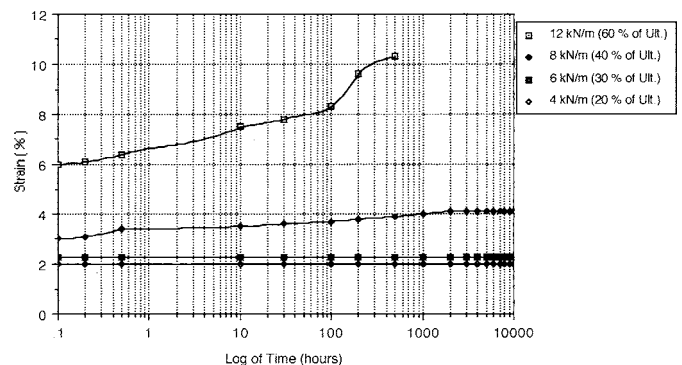

FIG. 1 Percent Strain versus Log of Time

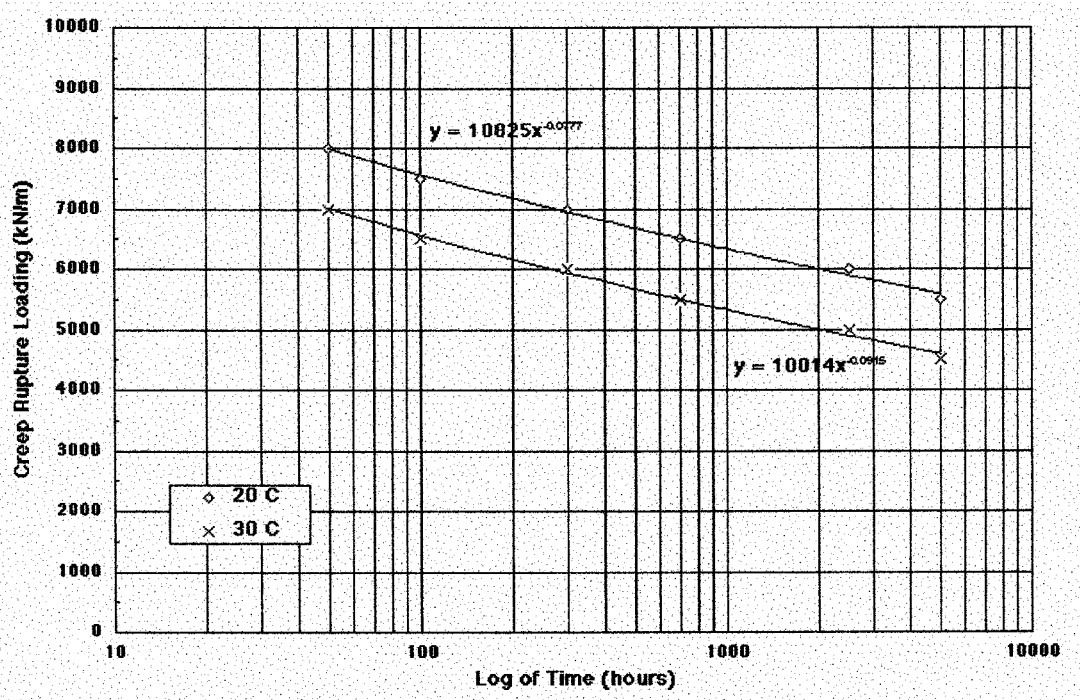

FIG. 2 Creep (Stress) Rupture versus Log of Time

where:

ϵ = strain, %,

ΔL = unit change in length from the pretension force to the corresponding applied force, mm (in.), and

L_g = initial nominal gage length plus the pretension displacement, mm (in.).

12.1.3 The data are then plotted as percent strain as ordinate versus log of time as abscissa. If several loads are used for testing, each plot shall be labeled clearly with the appropriate loading or force per unit width, expressed in kN/m (lb/in.). For geogrids, the equivalent force per unit width is determined by the use of Eq 2:

$$a = (F / N_R) \times N_T \quad (2)$$

where:

a = equivalent force per unit width, kN/m (lbf/ft),

F = applied force, kN (lbf),

N_R = number of ribs tested, and

N_T = number of ribs per unit width.

12.2 *Creep Rupture Curves*—The standard is a graph of creep rupture loading versus log of time, as shown in Fig. 2.

NOTE 7—Data could also be presented as log₁₀ of creep rupture loading versus log₁₀ of time.

NOTE 8—Data could also be presented with loading as a percent of ultimate tensile strength of the sample being tested versus log₁₀ of time.

12.2.1 *Time*—Elapsed time to rupture are converted to hours and converted to log time (in hours).

12.2.2 *Creep Rupture Loading* —Calculate the creep rupture loading to loading per unit width. For geogrids, the equivalent force per unit width is determined by the use of Eq 2.

12.2.3 The data are plotted as creep rupture loading as ordinate versus log of time as abscissa for a given test temperature, plot each set of coordinates (time, loading).

12.2.4 For a given test temperature, curve fit the data with an appropriate correlation (for example, power law), as shown in Fig. 2.

13. Report

13.1 Report the following information:

13.1.1 Note that the specimens were tested as directed in this test method. Describe the material tested, including all pertinent information required for complete identification of the specimen.

13.1.2 Provide all of the following applicable items for the machine direction and cross-machine direction of the material tested:

13.1.3 Dates of the creep or creep rupture test.

13.1.4 Dimensions of the test specimen.

13.1.5 Preconditioning used and description of test conditions, which includes the following: relative humidity; temperature or temperatures; loads used; type and weight of clamping system, which includes any special details of clamping utilized to test the specimen and the reason for special measures (for example, alloy used for gripping); loading mechanism; pretension load; and associated extension.

13.1.6 For each creep temperature, plot creep strain in percent versus log of time in hours under a given load per unit width and as a percent of ultimate load, as determined in appropriate ASTM test methods (see Fig. 1).

13.1.7 For each creep rupture temperature, plot creep rupture loads per unit width or as a percent of ultimate tensile

strength per unit width versus log of time in hours and as determined by the appropriate ASTM test methods (see Fig. 2).

NOTE 9—"Ultimate load" as referenced above is the tensile strength of the geosynthetic. The laboratory report generated after performing this test procedure must identify the tensile strength of the geosynthetic, and the test procedure used to determine this value. It is recommended that specimen(s) described in Section 8 of this standard are taken from the same roll for which the tensile strength has been determined in accordance with the appropriate ASTM test method.

14. Precision and Bias

14.1 Precision—The precision of the procedure in this test method is being established.

14.2 Bias—This test has no bias because the unconfined tension creep and creep rupture of geosynthetics is defined in terms of this test method.

15. Keywords

15.1 creep rupture; geogrid; geomembrane; geosynthetics; geotextile; tension creep

APPENDIXES

(Nonmandatory Information)

X1. CLAMPING SYSTEMS

See Fig. X1.1.

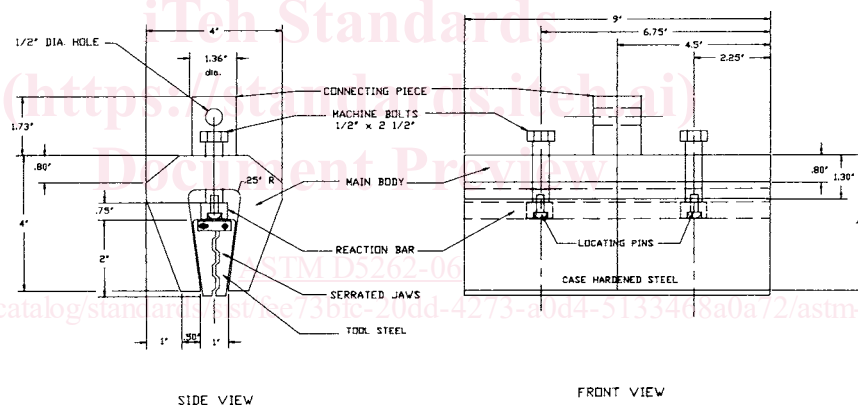

NOTE—Roller grips, not shown, are also suitable for tension creep testing.

FIG. X1.1 Suitable Tension Creep Clamping Systems

X2. LOADING SYSTEM

See Figs. X2.1 and X2.2.