

---

International Standard



753/5

---

INTERNATIONAL ORGANIZATION FOR STANDARDIZATION • МЕЖДУНАРОДНАЯ ОРГАНИЗАЦИЯ ПО СТАНДАРТИЗАЦИИ • ORGANISATION INTERNATIONALE DE NORMALISATION

---

**Acetic acid for industrial use — Methods of test —  
Part 5 : Determination of total acetaldehyde content —  
Titrimetric method**

*Acide acétique à usage industriel — Méthodes d'essai — Partie 5 : Dosage de l'acétaldéhyde total — Méthode titrimétrique*

First edition — 1981-10-15

**iTeh STANDARD PREVIEW**  
**(standards.iteh.ai)**

[ISO 753-5:1981](https://standards.iteh.ai/catalog/standards/sist/4f1730a2-4dbb-4c3b-85db-1cd15b0dc905/iso-753-5-1981)

<https://standards.iteh.ai/catalog/standards/sist/4f1730a2-4dbb-4c3b-85db-1cd15b0dc905/iso-753-5-1981>

---

UDC 661.731 : 543

Ref. No. ISO 753/5-1981 (E)

**Descriptors** : industrial products, acetic acid, tests, determination of content, acetaldehyde, titration.

## Foreword

ISO (the International Organization for Standardization) is a worldwide federation of national standards institutes (ISO member bodies). The work of developing International Standards is carried out through ISO technical committees. Every member body interested in a subject for which a technical committee has been set up has the right to be represented on that committee. International organizations, governmental and non-governmental, in liaison with ISO, also take part in the work.

Draft International Standards adopted by the technical committees are circulated to the member bodies for approval before their acceptance as International Standards by the ISO Council.

International Standard ISO 753/5 was developed by Technical Committee ISO/TC 47, *Chemistry*, and was circulated to the member bodies in March 1980.

iTeh STANDARD PREVIEW  
(standards.iteh.ai)

It has been approved by the member bodies of the following countries :

Australia	Germany, F. R.	South Africa, Rep. of
Austria	Hungary	Switzerland
Belgium	India	Thailand
Brazil	Italy	United Kingdom
China	Korea, Rep. of	USSR
Czechoslovakia	Netherlands	
Egypt, Arab Rep. of	Poland	
France	Romania	

<https://standards.iteh.ai/catalog/standards/sist/4f1730a2-4dbb-4c3b-85db-1cd15b0d6905/iso-753-5-1981>  
ISO 753-5:1981

No member body expressed disapproval of the document.

This International Standard has also been approved by the International Union of Pure and Applied Chemistry (IUPAC).

International Standards ISO 753/1 to ISO 753/11 cancel and replace ISO Recommendation R 753-1968, of which they constitute a technical revision.

# Acetic acid for industrial use — Methods of test — Part 5 : Determination of total acetaldehyde content — Titrimetric method

## 1 Scope and field of application

This part of ISO 753 specifies a titrimetric method for the determination of the total acetaldehyde content (polymerized and monomeric acetaldehyde) of acetic acid for industrial use.

The method is applicable to products having total acetaldehyde contents equal to or greater than 0,004 % (*m/m*).

This document should be read in conjunction with ISO 753/1 (see the annex).

NOTE — For the determination of the acetaldehyde monomer content, see ISO 753/4.

## 2 Reference

ISO/R 385, *Burettes*.

## 3 Principle

Heating a test portion in an acid medium to depolymerize any paraldehyde present and to entrain, by distillation, both regenerated acetaldehyde and the monomeric acetaldehyde originally present. Reaction of the acetaldehyde in the distillate with an excess of sodium hydrogen sulphite solution. Iodometric titration of the residual sodium hydrogen sulphite solution.

## 4 Reaction

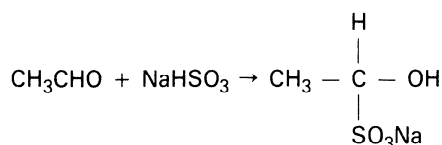

## 5 Reagents

During the analysis, use only reagents of recognized analytical grade and only distilled water or water of equivalent purity.

### 5.1 Sodium hydrogen sulphite, 12,6 g/l solution.

Dissolve 1,15 g of disodium disulphite ( $\text{Na}_2\text{S}_2\text{O}_5$ ) in water and dilute to 100 ml.

Prepare this solution at the time of use.

**5.2 Phosphoric acid**,  $\rho$  approximately 1,70 g/ml, about 85 % (*m/m*) solution.

**5.3 Iodine**, standard volumetric solution,  $c(1/2 \text{I}_2) = 0,1 \text{ mol/l}$ .

**5.4 Sodium thiosulphate**, standard volumetric solution,  $c(\text{Na}_2\text{S}_2\text{O}_3) = 0,1 \text{ mol/l}$ .

### 5.5 Starch solution.

Triturate 1,0 g of soluble starch with 5 ml of water and, whilst stirring, pour the mixture into 100 ml of boiling water. Boil for a few minutes and cool.

Discard the solution after 2 weeks.

ISO 753-5:1981  
<https://standards.iteh.ai/catalog/standards/sist/18770a41-d01a-4b5f-b21cd15b0dc905/iso-753-5-1981>

## 6 Apparatus

Ordinary laboratory apparatus and

**6.1 Weighing pipette**, of capacity 20 ml.

**6.2 Distillation apparatus**, with ground glass joints, assembled as shown in the figure and consisting of the following items.

**6.2.1 Distillation flask**, of capacity 250 ml, of borosilicate glass.

**6.2.2 Splash-head adapter**, fitted with a recovery bend.

**6.2.3 Water condenser**, carrying a

**6.2.4 Receiver adapter**.

**6.3 Conical flask**, of capacity 200 ml, graduated at 50 and 100 ml.

**6.4 Burette**, of capacity 50 ml, complying with the requirements of ISO/R 385, class A.

**6.5 Ice-water bath**.

**7 Procedure**

**7.1 Test portion**

Using the weighing pipette (6.1), weigh, to the nearest 0,000 1 g, a suitable quantity (usually 10 ml) of the laboratory sample and transfer it to the flask (6.2.1) containing 100 ml of water.

**7.2 Blank test**

Carry out a blank test at the same time as the determination, following the same procedure and using the same quantities of all the reagents [except the sodium thiosulphate solution (5.4)] as used for the determination, but omitting the test portion.

**7.3 Distillation**

Add 2 g of the phosphoric acid solution (5.2) to the distillation flask (6.2.1) containing the test portion (7.1), and place 40 ml of water and 10,0 ml of the sodium hydrogen sulphite solution (5.1) in the conical flask (6.3). Assemble the apparatus as shown in the figure, partially immersing the conical flask in the ice-water bath (6.5).

Bring the contents of the distillation flask (6.2.1) to gentle boiling in a few minutes and then slowly distil about 50 ml of liquid into the cooled conical flask.

Stop heating, disconnect the distillation flask and remove the ice-water bath. Rinse the inner walls of the condenser and of the receiver adapter with water, collecting the washings in the conical flask (6.3) and allow to stand at ambient temperature for 30 min. Then add 30,0 ml of the iodine solution (5.3).

**7.4 Titration**

Titrate the excess of the iodine solution with the sodium thiosulphate solution (5.4) from the burette (6.4) until the solution becomes pale yellow. Add 0,5 ml of the starch solution (5.5) and continue the titration until the blue colour is discharged.

**8 Expression of results**

The total acetaldehyde (CH<sub>3</sub>CHO) content, expressed as a percentage by mass, is given by the formula

$$0,002\ 2 (V_1 - V_0) \times \frac{100}{m}$$

$$= \frac{0,22 (V_1 - V_0)}{m}$$

where

$V_0$  is the volume, in millilitres, of the sodium thiosulphate solution (5.4) used for the blank test;

$V_1$  is the volume, in millilitres, of the sodium thiosulphate solution (5.4) used for the determination;

$m$  is the mass, in grams, of the test portion (7.1);

0,002 2 is the mass, in grams, of acetaldehyde corresponding to 1 ml of sodium thiosulphate solution,  $c(\text{Na}_2\text{S}_2\text{O}_3) = 0,100 \text{ mol/l}$ .

NOTE — If the concentrations of the standard volumetric solutions are not exactly as specified in the list of reagents, an appropriate correction should be made.

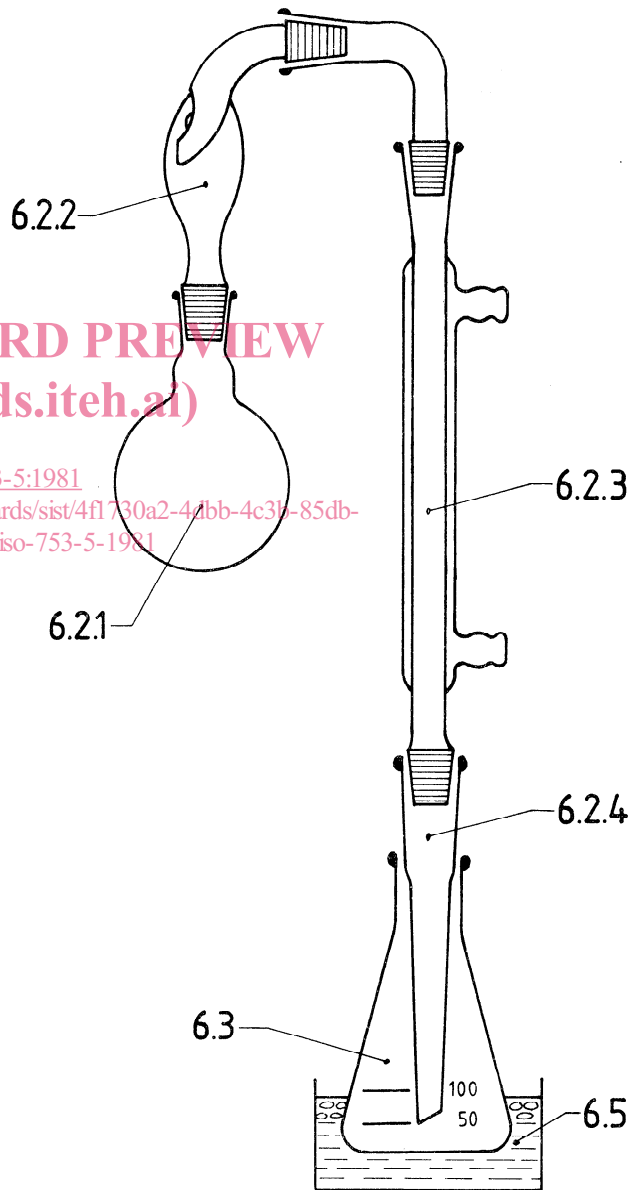

**Figure — Apparatus for the determination of total aldehyde content**

## Annex

### ISO publications relating to acetic acid for industrial use

ISO 753/1 – General.

ISO 753/2 – Determination of acetic acid content – Titrimetric method.

ISO 753/3 – Determination of low formic acid contents – Gravimetric method.

ISO 753/4 – Determination of acetaldehyde monomer content – Titrimetric method.

ISO 753/5 – Determination of total acetaldehyde content – Titrimetric method.

ISO 753/6 – Determination of permanganate index.

ISO 753/7 – Determination of dichromate index.

ISO 753/8 – Visual limit test for inorganic chlorides.

ISO 753/9 – Visual limit test for inorganic sulphates.

ISO 753/10 – Visual limit test for heavy metals (including iron).

ISO 753/11 – Determination of iron content – 1,10-Phenanthroline photometric method.

ITEH STANDARD PREVIEW  
(standards.iteh.ai)

[ISO 753-5:1981](https://standards.iteh.ai/catalog/standards/sist/4f1730a2-4dbb-4c3b-85db-1cd15b0dc905/iso-753-5-1981)

<https://standards.iteh.ai/catalog/standards/sist/4f1730a2-4dbb-4c3b-85db-1cd15b0dc905/iso-753-5-1981>

## **iTeh STANDARD PREVIEW**

This page intentionally left blank  
**(standards.iteh.ai)**

ISO 753-5:1981

<https://standards.iteh.ai/catalog/standards/sist/4f1730a2-4dbb-4c3b-85db-1cd15b0dc905/iso-753-5-1981>

## iTeh STANDARD PREVIEW

This page intentionally left blank  
(standards.iteh.ai)

ISO 753-5:1981

<https://standards.iteh.ai/catalog/standards/sist/4f1730a2-4dbb-4c3b-85db-1cd15b0dc905/iso-753-5-1981>

## **iTeh STANDARD PREVIEW**

This page intentionally left blank  
**(standards.iteh.ai)**

[ISO 753-5:1981](#)

<https://standards.iteh.ai/catalog/standards/sist/4f1730a2-4dbb-4c3b-85db-1cd15b0dc905/iso-753-5-1981>