

---

---

**Hand-held portable power tools — Test  
methods for evaluation of vibration  
emission —**

**Part 6:  
Rammers**

**iTeh STANDARD PREVIEW**  
*Machines à moteur portatives — Méthodes d'essai pour l'évaluation de  
l'émission de vibrations —  
(standards.iteh.ai)*  
*Partie 6: Marteaux fouloirs*

ISO 28927-6:2009

<https://standards.iteh.ai/catalog/standards/sist/440a594c-5dfd-4ef6-8c34-ccc5edc426d/iso-28927-6-2009>



**PDF disclaimer**

This PDF file may contain embedded typefaces. In accordance with Adobe's licensing policy, this file may be printed or viewed but shall not be edited unless the typefaces which are embedded are licensed to and installed on the computer performing the editing. In downloading this file, parties accept therein the responsibility of not infringing Adobe's licensing policy. The ISO Central Secretariat accepts no liability in this area.

Adobe is a trademark of Adobe Systems Incorporated.

Details of the software products used to create this PDF file can be found in the General Info relative to the file; the PDF-creation parameters were optimized for printing. Every care has been taken to ensure that the file is suitable for use by ISO member bodies. In the unlikely event that a problem relating to it is found, please inform the Central Secretariat at the address given below.

**iTeh STANDARD PREVIEW**  
**(standards.iteh.ai)**

[ISO 28927-6:2009](https://standards.iteh.ai/catalog/standards/sist/440a594c-5dfd-4ef6-8c34-ccc5edc426d/iso-28927-6-2009)

<https://standards.iteh.ai/catalog/standards/sist/440a594c-5dfd-4ef6-8c34-ccc5edc426d/iso-28927-6-2009>



**COPYRIGHT PROTECTED DOCUMENT**

© ISO 2009

All rights reserved. Unless otherwise specified, no part of this publication may be reproduced or utilized in any form or by any means, electronic or mechanical, including photocopying and microfilm, without permission in writing from either ISO at the address below or ISO's member body in the country of the requester.

ISO copyright office  
Case postale 56 • CH-1211 Geneva 20  
Tel. + 41 22 749 01 11  
Fax + 41 22 749 09 47  
E-mail [copyright@iso.org](mailto:copyright@iso.org)  
Web [www.iso.org](http://www.iso.org)

Published in Switzerland

# Contents

Page

|  |           |
|--|-----------|
| Foreword .....   | iv        |
| Introduction.....  | vi        |
| <b>1 Scope .....</b>   | <b>1</b>  |
| <b>2 Normative references .....</b>  | <b>1</b>  |
| <b>3 Terms, definitions and symbols .....</b>  | <b>2</b>  |
| 3.1 Terms and definitions .....  | 2         |
| 3.2 Symbols.....   | 2         |
| <b>4 Basic standards and vibration test codes .....</b>                                | <b>2</b>  |
| <b>5 Description of the family of machines .....</b>                                   | <b>2</b>  |
| <b>6 Characterization of vibration.....</b>  | <b>4</b>  |
| 6.1 Direction of measurement .....   | 4         |
| 6.2 Location of measurements.....  | 4         |
| 6.3 Magnitude of vibration .....   | 5         |
| 6.4 Combination of vibration directions.....   | 5         |
| <b>7 Instrumentation requirements.....</b>   | <b>5</b>  |
| 7.1 General .....  | 5         |
| 7.2 Mounting of transducers .....  | 5         |
| 7.3 Frequency weighting filter.....  | 6         |
| 7.4 Integration time.....  | 6         |
| 7.5 Auxiliary equipment.....   | 6         |
| 7.6 Calibration .....  | 6         |
| <b>8 Testing and operating conditions of the machinery.....</b>                        | <b>6</b>  |
| 8.1 General .....  | 6         |
| 8.2 Operating conditions .....   | 7         |
| 8.3 Other quantities to be specified.....  | 7         |
| 8.4 Attached equipment, work piece and task.....                                       | 7         |
| 8.5 Operators.....   | 9         |
| <b>9 Measurement procedure and validity.....</b>                                       | <b>9</b>  |
| 9.1 Reported vibration values .....  | 9         |
| 9.2 Declaration and verification of the vibration emission value .....                 | 9         |
| <b>10 Measurement report .....</b>   | <b>10</b> |
| <b>Annex A (informative) Model test report for vibration emission of rammers .....</b> | <b>11</b> |
| <b>Annex B (normative) Determination of uncertainty.....</b>                           | <b>13</b> |
| <b>Annex C (normative) Design of energy absorbers for rammers.....</b>                 | <b>15</b> |
| <b>Bibliography.....</b>   | <b>16</b> |

## Foreword

ISO (the International Organization for Standardization) is a worldwide federation of national standards bodies (ISO member bodies). The work of preparing International Standards is normally carried out through ISO technical committees. Each member body interested in a subject for which a technical committee has been established has the right to be represented on that committee. International organizations, governmental and non-governmental, in liaison with ISO, also take part in the work. ISO collaborates closely with the International Electrotechnical Commission (IEC) on all matters of electrotechnical standardization.

International Standards are drafted in accordance with the rules given in the ISO/IEC Directives, Part 2.

The main task of technical committees is to prepare International Standards. Draft International Standards adopted by the technical committees are circulated to the member bodies for voting. Publication as an International Standard requires approval by at least 75 % of the member bodies casting a vote.

Attention is drawn to the possibility that some of the elements of this document may be the subject of patent rights. ISO shall not be held responsible for identifying any or all such patent rights.

ISO 28927-6 was prepared by Technical Committee ISO/TC 118, *Compressors and pneumatic tools, machines and equipment*, Subcommittee SC 3, *Pneumatic tools and machines*.

This first edition of ISO 28927-6 cancels and replaces ISO 8662-9:1996, of which it constitutes a technical revision. The most important changes are **(standards.iteh.ai)**

- vibration measurement in three axes and at both hand positions,
- new transducer positions, and
- improved definition of transducer positions and orientation.

ISO 28927 consists of the following parts, under the general title *Hand-held portable power tools — Test methods for evaluation of vibration emission*:

- *Part 1: Angle and vertical grinders*<sup>1)</sup>
- *Part 2: Wrenches, nutrunners and screwdrivers*<sup>2)</sup>
- *Part 3: Polishers and rotary, orbital and random orbital sanders*<sup>3)</sup>
- *Part 4: Straight grinders*<sup>4)</sup>

---

1) Together with Part 4, replaces ISO 8662-4, *Hand-held portable power tools — Measurement of vibrations at the handle — Part 4: Grinders*.

2) Replaces ISO 8662-7, *Hand-held portable power tools — Measurement of vibrations at the handle — Part 7: Wrenches, screwdrivers nut runners with impact, impulse and ratcheting action*. All screwdrivers and nutrunners except for one-shot tools now covered.

3) Replaces ISO 8662-8, *Hand-held portable power tools — Measurement of vibrations at the handle — Part 8: Polishers and rotary, orbital and random orbital sanders*.

4) Together with Part 1, replaces ISO 8662-4, *Hand-held portable power tools — Measurement of vibrations at the handle — Part 4: Grinders*.

- Part 5: Drills and impact drills<sup>5)</sup>
- Part 6: Rammers
- Part 7: Nibblers and shears<sup>6)</sup>
- Part 8: Saws, polishing and filing machines with reciprocating action and small saws with oscillating or rotating action<sup>7)</sup>
- Part 9: Scaling hammers and needle scalers<sup>8)</sup>
- Part 10: Percussive drills, hammers and breakers<sup>9)</sup>
- Part 11: Stone hammers<sup>10)</sup>

## iTeh STANDARD PREVIEW (standards.iteh.ai)

[ISO 28927-6:2009](https://standards.iteh.ai/catalog/standards/sist/440a594c-5dfd-4ef6-8c34-ccc5edc426d/iso-28927-6-2009)

<https://standards.iteh.ai/catalog/standards/sist/440a594c-5dfd-4ef6-8c34-ccc5edc426d/iso-28927-6-2009>

---

5) Replaces ISO 8662-6, *Hand-held portable power tools — Measurement of vibrations at the handle — Part 6: Impact drills*. Non-impacting drills now covered.

6) Replaces ISO 8662-10, *Hand-held portable power tools — Measurement of vibrations at the handle — Part 10: Nibblers and shears*.

7) Replaces ISO 8662-12, *Hand-held portable power tools — Measurement of vibrations at the handle — Part 12: Saws and files with reciprocating action and saws with oscillating or rotating action*.

8) Together with Part 11, replaces ISO 8662-14, *Hand-held portable power tools — Measurement of vibrations at the handle — Part 14: Stone-working tools and needle scalers*.

9) Replaces ISO 8662-2, *Hand-held portable power tools — Measurement of vibrations at the handle — Part 2: Chipping hammers and riveting hammers*, ISO 8662-3, *Hand-held portable power tools — Measurement of vibrations at the handle — Part 3: Rock drills and rotary hammers*, and ISO 8662-5, *Hand-held portable power tools — Measurement of vibrations at the handle — Part 5: Pavement breakers and hammers for construction work*. Chipping and riveting hammers, rock drills and rotary hammers all covered.

10) Together with Part 9, replaces ISO 8662-14, *Hand-held portable power tools — Measurement of vibrations at the handle — Part 14: Stone-working tools and needle scalers*.

## Introduction

This document is a type-C standard as stated in ISO 12100.

When requirements of this type-C standard are different from those which are stated in type-A or -B standards, the requirements of this type-C standard take precedence over the requirements of the other standards for machines that have been designed and built according to the requirements of this type-C standard.

The vibration test codes for portable hand-held machines given in ISO 28927 are based on ISO 20643, which gives general specifications for the measurement of the vibration emission of hand-held and hand-guided machinery. ISO 28927 specifies the operation of the machines under type-test conditions and other requirements for the performance of type tests. The structure/numbering of its clauses follows that of ISO 20643.

The basic principle for transducer positioning first introduced in the EN 60745 series of European standards is followed, representing a deviation from ISO 20643 for reasons of consistency. The transducers are primarily positioned next to the hand in the area between the thumb and the index finger, where they give the least disturbance to the operator gripping the machine.

It has been found that vibrations generated by rammers vary considerably in typical use. For rammers, the percussion action is the source of vibration, and the variation is largely due to variations in the handling of the rammer and the damping characteristics of the material worked on.

In order to provide a method that gives good measurement reproducibility, this part of ISO 28927 uses a working process where the rammer is used on an energy absorber, thereby giving damping characteristics that will be constant over time. The procedures of ISO 5349 are required whenever exposure at the workplace is to be assessed.

The values obtained are type-test values intended to be representative of the average of the upper quartile of typical vibration magnitudes in real-world use of the machines. However, the actual magnitudes will vary considerably from time to time and depend on many factors, including the operator, the task and the inserted tool or consumable. The state of maintenance of the machine itself might also be of importance. Under real working conditions the influences of the operator and process can be particularly important at low magnitudes. It is therefore not recommended that emission values below 2,5 m/s<sup>2</sup> be used for estimating the vibration magnitude under real working conditions. In such cases, 2,5 m/s<sup>2</sup> is the recommended vibration magnitude for estimating the machine vibration.

If accurate values for a specific work place are required, then measurements (according to ISO 5349) in that work situation could be necessary. Vibration values measured in real working conditions can be either higher or lower than the values obtained using this part of ISO 28927.

Higher vibration magnitudes can easily occur in real work situations, caused by an improper combination of butt and rammed material.

The vibration test codes given in ISO 28927 supersede those given in ISO 8662, whose parts have been replaced by the corresponding parts of ISO 28927 (see Foreword).

NOTE ISO 8662-11, *Hand-held portable power tools — Measurement of vibrations at the handle — Part 11: Fastener driving tools*, and ISO 8662-13, *Hand-held portable power tools — Measurement of vibrations at the handle — Part 13: Die grinders*, could be replaced by future parts of ISO 28927.

# Hand-held portable power tools — Test methods for evaluation of vibration emission —

## Part 6: Rammers

### 1 Scope

This part of ISO 28927 specifies a laboratory method for measuring hand-transmitted vibration emission at the handles of hand-held, power-driven rammers. It is a type-test procedure for establishing the magnitude of vibration in the gripping areas of a machine run under specified test conditions. It is intended that the results be used to compare different models of the same type of machine.

This part of ISO 28927 is applicable to rammers, back-fill rammers, pawing rammers, sand rammers and stampers (see Clause 5), driven pneumatically or by other means, intended for use in foundries, on building sites, etc., and with, for example, butts or peens made of cast iron or rubber, used for ramming of casting sand or in stamping work.

NOTE To avoid confusion with the terms “power tool” and “inserted tool”, *machine* is used for the former throughout this document.

[ISO 28927-6:2009](https://standards.iteh.ai/catalog/standards/sist/440a594c-5dfd-4ef6-8c34-ccc5edc426d/iso-28927-6-2009)

<https://standards.iteh.ai/catalog/standards/sist/440a594c-5dfd-4ef6-8c34-ccc5edc426d/iso-28927-6-2009>

### 2 Normative references

The following referenced documents are indispensable for the application of this document. For dated references, only the edition cited applies. For undated references, the latest edition of the referenced document (including any amendments) applies.

ISO 2787:1984, *Rotary and percussive pneumatic tools — Performance tests*

ISO 5349:2001 (all parts), *Mechanical vibration — Measurement and evaluation of human exposure to hand-transmitted vibration*

ISO 5391:2003, *Pneumatic tools and machines — Vocabulary*

ISO 17066:2007, *Hydraulic tools — Vocabulary*

ISO 20643:2005, *Mechanical vibration — Hand-held and hand-guided machinery — Principles for evaluation of vibration emission*

EN 12096:1997, *Mechanical vibration — Declaration and verification of vibration emission values*

### 3 Terms, definitions and symbols

For the purposes of this document, the terms and definitions given in ISO 5391, ISO 17066 and ISO 20643, and the following terms, definitions and symbols, apply.

#### 3.1 Terms and definitions

##### 3.1.1

**rammer**

**backfill tamper**

percussive machine for compressing earth, casting sand, etc.

NOTE Adapted from ISO 5391:2003, definition 2.2.8.

#### 3.2 Symbols

| Symbol              | Description  | Unit             |
|---------------------|--|------------------|
| $a_{hw}$            | root-mean-square (r.m.s.) single-axis acceleration value of the frequency-weighted hand-transmitted vibration                                    | m/s <sup>2</sup> |
| $a_{hv}$            | vibration total value of frequency-weighted r.m.s. acceleration; root sum of squares of $a_{hw}$ values for the three measured axes of vibration | m/s <sup>2</sup> |
| $\overline{a_{hv}}$ | arithmetic mean value of $a_{hv}$ values of runs for single operator using one hand position   | m/s <sup>2</sup> |
| $a_h$               | arithmetic mean value of $a_{hv}$ values for all operators for one hand position   | m/s <sup>2</sup> |
| $\overline{a_h}$    | arithmetic mean value of $a_h$ values for one hand position on several machines  | m/s <sup>2</sup> |
| $a_{hd}$            | declared vibration emission value  | m/s <sup>2</sup> |
| $s_{n-1}$           | standard deviation for a test series (for a sample, $s$ )  | m/s <sup>2</sup> |
| $\sigma_R$          | standard deviation of reproducibility (for a population, $\sigma$ )  | m/s <sup>2</sup> |
| $C_v$               | coefficient of variation for a test series   |                  |
| $K$                 | uncertainty  | m/s <sup>2</sup> |

### 4 Basic standards and vibration test codes

This part of ISO 28297 is based on the requirements of ISO 20643 and corresponds to its structure in respect of clause subjects and numbering except for the annexes.

Annex A presents a model test report, Annex B the means for determining the uncertainty,  $K$ , and Annex C the design of energy absorbers for rammers.

### 5 Description of the family of machines

This part of ISO 29827 applies to hand-held machines intended for ramming casting sand or in stamping work.

Figures 1 and 2 show examples of typical rammers covered by this part of ISO 29827.





**iTeh STANDARD PREVIEW**

**Figure 1 — Rammer for use on floors**  
(standards.iteh.ai)

ISO 28927-6:2009  
<https://standards.iteh.ai/catalog/standards/sist/440a594c-5dfd-4ef6-8c34-ccc5edc426d/iso-28927-6-2009>



**Figure 2 — Rammer for use on benches**

## 6 Characterization of vibration

### 6.1 Direction of measurement

The vibration transmitted to the hand shall be measured and reported for three directions of an orthogonal coordinate system. At each hand position, the vibration shall be measured simultaneously in the three directions shown in Figures 3 and 4.

### 6.2 Location of measurements

Measurements shall be made at the gripping zones, where the operator normally holds the machine and applies the feed force. For machines intended for one-handed operation, it is only necessary to measure at a single point.

The prescribed transducer location shall be as close as possible to the hand between the thumb and index finger. This shall apply to both hand positions, with the machine held as in normal operation. Whenever possible, measurements shall be made at the prescribed locations.

A secondary location is defined as being on the side of, and as close as possible to, the inner end of the handle where the prescribed location is found. If the prescribed location of the transducer cannot be used, this secondary location shall be used instead.

The prescribed or secondary location shall also be used on anti-vibration handles.

Figures 3 and 4 show the prescribed and secondary locations and measurement directions for the hand positions normally used for the different types of machines in this family.

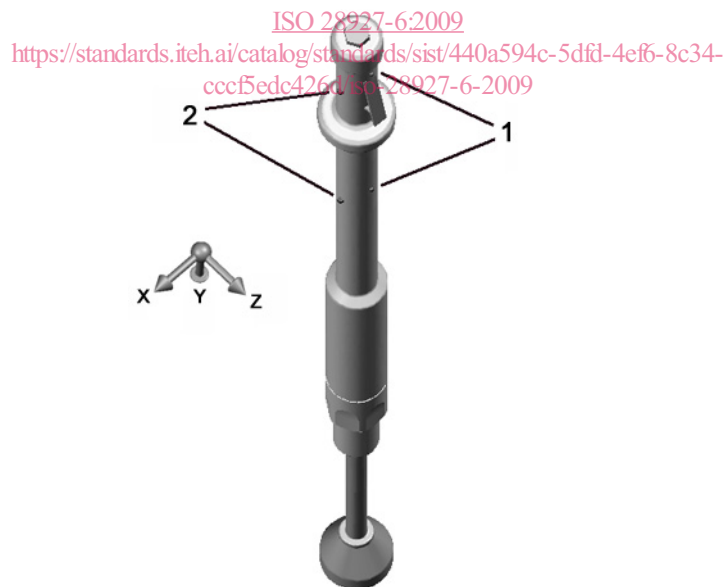

#### Key

- 1 prescribed location
- 2 secondary location

Figure 3 — Measurement locations — Rammer for use on floors

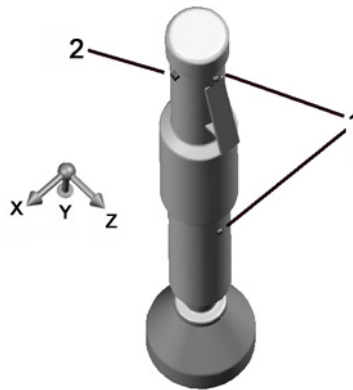

#### Key

- 1 prescribed location
- 2 secondary location

**Figure 4 — Measurement locations — Rammer for use on benches**

### 6.3 Magnitude of vibration

The definitions for the magnitude of vibration given in ISO 20643:2005, 6.3, apply.

### 6.4 Combination of vibration directions

The vibration total value defined in ISO 20643:2005, 6.4, shall be reported for both hand positions when applicable. It is acceptable to report on and carry out tests on the hand position having the highest reading. The vibration total value at that hand position shall be at least 30 % higher than the other. This result may be obtained during a preliminary test carried out by a single operator during five test runs.

To obtain the vibration total value,  $a_{hv}$ , for each test run, the results in each direction shall be combined using Equation (1):

$$a_{hv} = \sqrt{a_{hwx}^2 + a_{hwy}^2 + a_{hwz}^2} \quad (1)$$

## 7 Instrumentation requirements

### 7.1 General

The instrumentation shall be in accordance with ISO 20643:2005, 7.1.

### 7.2 Mounting of transducers

#### 7.2.1 Specification of transducer

The specification of the transducer given in ISO 20643:2005, 7.2.1, applies.

The total mass of the transducers and mounting device shall be small enough, compared with that of the machine, handle, etc., so as not to influence the measurement result.

This is particularly important for low-mass plastic handles (see ISO 5349-2).