

---

---

**Rubber, vulcanized — Determination of  
temperature rise and resistance to fatigue  
in flexometer testing —**

Part 3:  
**Compression flexometer  
(constant-strain type)**

iTeh STANDARD PREVIEW

(standards.iteh.ai)  
*Caoutchouc vulcanisé — Détermination de l'élévation de température et  
de la résistance à la fatigue dans les essais aux flexomètres —*

*Partie 3: Flexomètre à compression (type à déformation constante)*

[https://standards.iteh.ai/catalog/standards/sist/c31e4b7f-850d-495c-a439-  
bea2088d6fd7/iso-4666-3-2010](https://standards.iteh.ai/catalog/standards/sist/c31e4b7f-850d-495c-a439-bea2088d6fd7/iso-4666-3-2010)



**PDF disclaimer**

This PDF file may contain embedded typefaces. In accordance with Adobe's licensing policy, this file may be printed or viewed but shall not be edited unless the typefaces which are embedded are licensed to and installed on the computer performing the editing. In downloading this file, parties accept therein the responsibility of not infringing Adobe's licensing policy. The ISO Central Secretariat accepts no liability in this area.

Adobe is a trademark of Adobe Systems Incorporated.

Details of the software products used to create this PDF file can be found in the General Info relative to the file; the PDF-creation parameters were optimized for printing. Every care has been taken to ensure that the file is suitable for use by ISO member bodies. In the unlikely event that a problem relating to it is found, please inform the Central Secretariat at the address given below.

**iTeh STANDARD PREVIEW**  
**(standards.iteh.ai)**

ISO 4666-3:2010

<https://standards.iteh.ai/catalog/standards/sist/c31e4b7f-850d-495c-a439-bea2088d6fd7/iso-4666-3-2010>



**COPYRIGHT PROTECTED DOCUMENT**

© ISO 2010

All rights reserved. Unless otherwise specified, no part of this publication may be reproduced or utilized in any form or by any means, electronic or mechanical, including photocopying and microfilm, without permission in writing from either ISO at the address below or ISO's member body in the country of the requester.

ISO copyright office  
Case postale 56 • CH-1211 Geneva 20  
Tel. + 41 22 749 01 11  
Fax + 41 22 749 09 47  
E-mail [copyright@iso.org](mailto:copyright@iso.org)  
Web [www.iso.org](http://www.iso.org)

Published in Switzerland

**Contents**

Page

<b>Foreword</b> .....	<b>iv</b>
<b>Introduction</b> .....	<b>v</b>
<b>1 Scope</b> .....	<b>1</b>
<b>2 Normative references</b> .....	<b>1</b>
<b>3 Terms and definitions</b> .....	<b>2</b>
<b>4 Principle</b> .....	<b>2</b>
<b>5 Apparatus</b> .....	<b>2</b>
<b>5.1 Flexometer</b> .....	<b>2</b>
<b>5.2 Measuring gauge</b> .....	<b>4</b>
<b>5.3 Timer</b> .....	<b>4</b>
<b>6 Calibration</b> .....	<b>5</b>
<b>7 Test piece</b> .....	<b>5</b>
<b>8 Test conditions</b> .....	<b>5</b>
<b>9 Procedure</b> .....	<b>6</b>
<b>9.1 Preparation of flexometer</b> .....	<b>6</b>
<b>9.2 Test procedure</b> .....	<b>6</b>
<b>10 Expression of results</b> .....	<b>8</b>
<b>10.1 Temperature rise</b> .....	<b>8</b>
<b>10.2 Creep</b> .....	<b>8</b>
<b>10.3 Compression set</b> .....	<b>8</b>
<b>10.4 Fatigue life</b> .....	<b>9</b>
<b>11 Test report</b> .....	<b>9</b>
<b>Annex A (informative) Precision</b> .....	<b>10</b>
<b>Annex B (informative) Guidance for using precision results</b> .....	<b>12</b>
<b>Annex C (normative) Calibration schedule</b> .....	<b>13</b>
<b>Bibliography</b> .....	<b>15</b>

## Foreword

ISO (the International Organization for Standardization) is a worldwide federation of national standards bodies (ISO member bodies). The work of preparing International Standards is normally carried out through ISO technical committees. Each member body interested in a subject for which a technical committee has been established has the right to be represented on that committee. International organizations, governmental and non-governmental, in liaison with ISO, also take part in the work. ISO collaborates closely with the International Electrotechnical Commission (IEC) on all matters of electrotechnical standardization.

International Standards are drafted in accordance with the rules given in the ISO/IEC Directives, Part 2.

The main task of technical committees is to prepare International Standards. Draft International Standards adopted by the technical committees are circulated to the member bodies for voting. Publication as an International Standard requires approval by at least 75 % of the member bodies casting a vote.

Attention is drawn to the possibility that some of the elements of this document may be the subject of patent rights. ISO shall not be held responsible for identifying any or all such patent rights.

ISO 4666-3 was prepared by Technical Committee ISO/TC 45, *Rubber and rubber products*, Subcommittee SC 2, *Testing and analysis*.

This second edition cancels and replaces the first edition (ISO 4666-3:1982), which has been revised to update the normative references (ISO 4648 has been replaced by ISO 23529). In addition, the layout of Clause 11, the test report, has been updated. The text has also been clarified in places. A precision statement and calibration schedule are added as annexes. Finally, the title has been changed to make a clear distinction from ISO 4666-4 (constant-stress flexometer).

ISO 4666 consists of the following parts, under the general title *Rubber, vulcanized — Determination of temperature rise and resistance to fatigue in flexometer testing*:

- *Part 1: Basic principles*
- *Part 2: Rotary flexometer*
- *Part 3: Compression flexometer (constant-strain type)*
- *Part 4: Constant-stress flexometer*

## Introduction

One major consequence of the internal heat generation of rubber under a flexing compression is the development of an elevated temperature in the rubber. This International Standard provides for the measurement of the temperature rise.

Under particularly severe heat generation and temperature rise conditions, internal rupture of the test piece may occur with fatigue failure. Provision is also made for the measurement of resistance to this type of fatigue.

The test is conducted under conditions of a selected static pre-stress or compression and a selected cyclic strain of constant maximum amplitude imposed upon the pre-stressed test piece.

## iTeh STANDARD PREVIEW (standards.iteh.ai)

[ISO 4666-3:2010](https://standards.iteh.ai/catalog/standards/sist/c31e4b7f-850d-495c-a439-bea2088d6fd7/iso-4666-3-2010)

<https://standards.iteh.ai/catalog/standards/sist/c31e4b7f-850d-495c-a439-bea2088d6fd7/iso-4666-3-2010>

**iTeh STANDARD PREVIEW**  
**(standards.iteh.ai)**

ISO 4666-3:2010

<https://standards.iteh.ai/catalog/standards/sist/c31e4b7f-850d-495c-a439-bea2088d6fd7/iso-4666-3-2010>

# Rubber, vulcanized — Determination of temperature rise and resistance to fatigue in flexometer testing —

## Part 3: Compression flexometer (constant-strain type)

**WARNING** — Persons using this International Standard should be familiar with normal laboratory practice. This standard does not purport to address all of the safety problems, if any, associated with its use. It is the responsibility of the user to establish appropriate safety and health practices and to ensure compliance with any national regulatory conditions.

**CAUTION** — Certain procedures specified in this International Standard may involve the use or generation of substances, or the generation of waste, that could constitute a local environmental hazard. Reference should be made to appropriate documentation on safe handling and disposal after use.

### iTeh STANDARD PREVIEW (standards.iteh.ai)

## 1 Scope

This part of ISO 4666 specifies the flexometer test with constant-strain amplitude for the determination of the temperature rise and resistance to fatigue of vulcanized rubber. The flexometer specified is known as the Goodrich flexometer, but any other apparatus giving equivalent performance can be used.

This part of ISO 4666 gives directions for carrying out measurements which make possible predictions regarding the durability of rubbers in finished articles subject to dynamic flexing in service such as tyres, bearings, supports, V-belts, and cable-pulley insert rings. However, owing to the wide variations in service conditions, no simple correlation between the accelerated tests described in the various parts of this International Standard and service performance can be assumed.

The method is not recommended for rubber having a hardness greater than 85 IRHD.

## 2 Normative references

The following referenced documents are indispensable for the application of this document. For dated references, only the edition cited applies. For undated references, the latest edition of the referenced document (including any amendments) applies.

ISO 48, *Rubber, vulcanized or thermoplastic — Determination of hardness (hardness between 10 IRHD and 100 IRHD)*

ISO 4666-1, *Rubber, vulcanized — Determination of temperature rise and resistance to fatigue in flexometer testing — Part 1: Basic principles*

ISO 23529, *Rubber — General procedures for preparing and conditioning test pieces for physical test methods*

ISO 18899:2004, *Rubber — Guide to the calibration of test equipment*

### 3 Terms and definitions

For the purposes of this document, the terms and definitions given in ISO 4666-1 apply.

### 4 Principle

A specified compressive load is applied to a test piece through a lever system having high inertia, while imposing on the test piece an additional high-frequency cyclic compression of specified amplitude. Measurements are made of the increase in temperature at the base of the test piece with a thermocouple which provides a relative indication of the heat generated in flexing the test piece and of the number of cycles which produces fatigue breakdown.

With the test piece subject to a constant applied load or to a constant initial compression during the test, continuous measurement is made of the change in height of the test piece. The compression set of the test piece is measured after testing.

### 5 Apparatus

#### 5.1 Flexometer

##### 5.1.1 General description

The essential parts of the apparatus are shown in Figure 1.

The test piece is placed between anvils faced with a thermal insulating material. The top anvil is connected to an adjustable eccentric usually driven at an oscillation rate of  $30 \text{ Hz} \pm 0,2 \text{ Hz}$ .

An anvil is sometimes called a "plate". However, do not confuse "anvil" with the plate described in Clause 7.

The load is applied by means of a lever resting on a knife edge. The moment of inertia of the lever system is increased and its natural frequency reduced by suspending masses of 24 kg at each end of the lever system. The lower anvil can be raised or lowered relative to the lever by means of a calibrated micrometer device. This device permits the lever system to be maintained in a horizontal position during the test as determined by a pointer and a reference mark on the end of the bar.

The increase in temperature at the base of the test piece is determined by means of a thermocouple placed at the centre of the bottom anvil.

##### 5.1.2 Detailed description

The apparatus (see Figure 1) consists of a balance beam (6) which can be locked in its horizontal position by means of a steel pin. The beam is provided with masses of 24 kg (8) at both ends. The distance between the knife edge supporting the beam and the edges supporting the masses is  $288 \text{ mm} \pm 0,5 \text{ mm}$ . An equivalent inertial system can be used.

The test piece (2) is placed upon an anvil (3) on one arm of the balance beam. The distance of the test piece support (10) from the fulcrum is  $127 \text{ mm} \pm 0,5 \text{ mm}$ . On the other side of the balance beam, additional masses (7) are placed in order to apply a load to the test piece. The desired weights are 11 kgf or 22 kgf which correspond to a pre-stress of  $1,0 \text{ MPa} \pm 0,03 \text{ MPa}$  or  $2,0 \text{ MPa} \pm 0,06 \text{ MPa}$ , respectively.

The test piece (2) is placed between the anvils (1 and 3), which are made of a thermal insulating material having a thermal conductivity of not more than  $0,28 \text{ W/(m}\cdot\text{K)}$  or, equivalently,  $0,24 \text{ kcal/(h}\cdot\text{m}\cdot\text{°C)}$ . Phenolic hardpaper can be used for this purpose. In the centre of the lower anvil, a thermocouple, e.g. iron-constantan, is attached for temperature measurement. The sensing point of the thermocouple shall be in contact with the test piece. The sensitivity of the thermocouple shall be  $\pm 0,5 \text{ °C}$ .

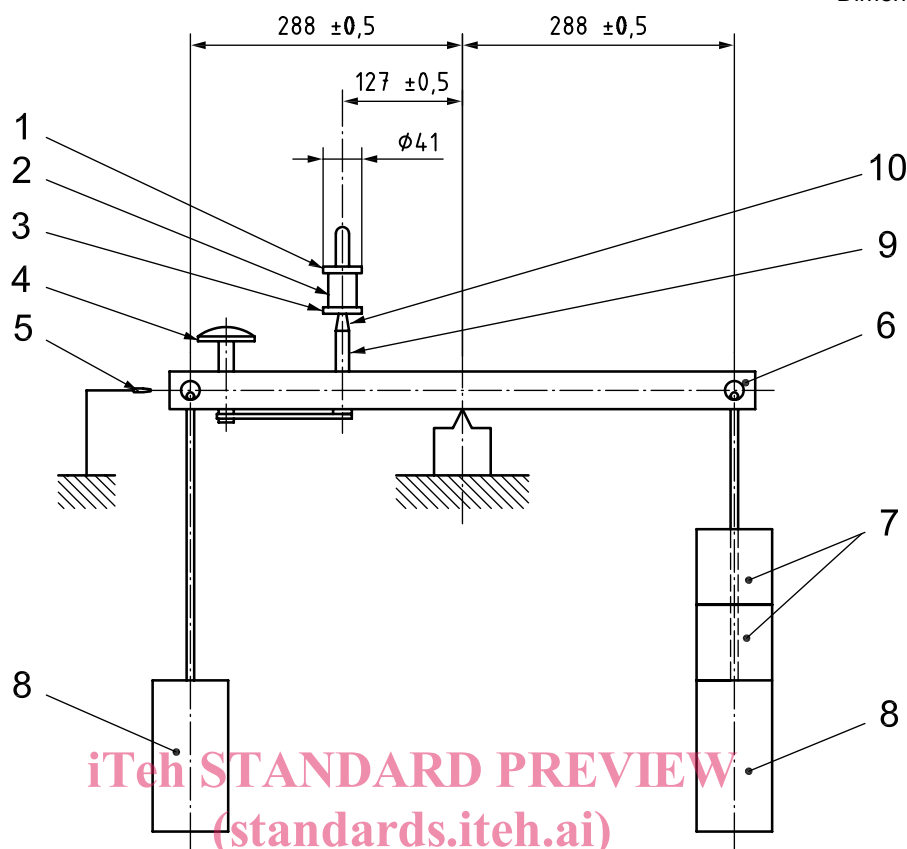

Dimensions in millimetres

**Key**

1 upper anvil	5 pointer	9 screw
2 test piece	6 balance beam	10 test piece support
3 lower anvil	7 additional masses	
4 micrometer screw	8 masses	

**Figure 1 — Compression flexometer (constant-strain type) — General arrangement**

Means shall be provided for measuring the decrease in height of the test piece, as the test proceeds, with an accuracy of 0,1 mm. For this purpose, the distance between the lower and upper anvils can be varied by means of a calibrated micrometer device until it returns to the horizontal position, which can be recognized by a mark on the balance beam and a pointer (5) on the casing. The adjustment device consists of a micrometer screw (4) which, by means of a chain and sprocket-wheel drive, moves the screw (9) up or down without rotating the lower anvil (3). The degree of adjustment is read from the micrometer screw (4). The centre point of the upper anvil (1) remains in the same position. The upper anvil (1) is connected through a guide bearing to a motor at  $30 \text{ Hz} \pm 0,2 \text{ Hz}$ .

Figure 2 shows a heating chamber. The test piece (7) with the supporting anvils is located in the chamber, the temperature of which can be maintained to within  $\pm 1 \text{ }^\circ\text{C}$  of a test temperature generally in the range  $40 \text{ }^\circ\text{C}$  to  $100 \text{ }^\circ\text{C}$ . The chamber shall have the following dimensions:

- width 100 mm;
- depth 130 mm;
- height 230 mm.

The bottom of the chamber shall be situated  $25 \text{ mm} \pm 2 \text{ mm}$  above the balance beam (9).

A thermocouple of the same type as that used in the lower anvil (8) shall be used for measurement of the temperature in the chamber. The thermocouple shall be positioned at a distance of 6 mm to 9 mm towards the right-hand side behind the rear edge of the anvil and at a height midway between the anvils. A length of at least 100 mm of the thermocouple wire shall be within the chamber.

The air circulation within the chamber is provided by a radial fan (4) of 75 mm diameter, operating at a rotational frequency of 25 Hz to 28 Hz. The air intake shall have a diameter of 60 mm. The air outlet (5) shall measure 40 mm × 45 mm. The grid shelf for supporting the test piece during conditioning (2) shall be fitted 10 mm ± 2 mm above the bottom of the chamber.

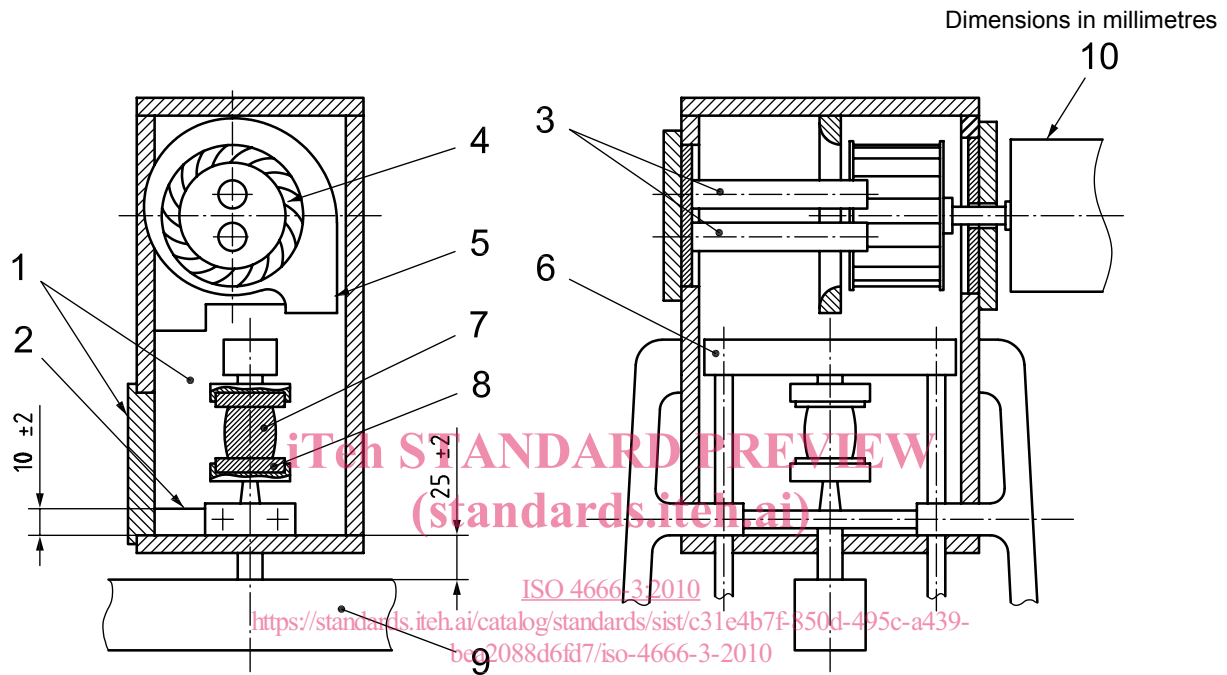

**Key**

- |   |  |
|---|--|
| 1 heating chamber with door                                 | 6 crossbar with lifting rods and upper anvil |
| 2 grid shelf for supporting test pieces during conditioning | 7 test piece                                 |
| 3 heating elements  | 8 lower anvil with thermocouple              |
| 4 radial fan  | 9 balance beam                               |
| 5 air outlet  | 10 motor of radial fan                       |

**Figure 2 — Example of a heating chamber**

**5.2 Measuring gauge**

The gauge for measuring the height and diameter of test pieces shall conform to the requirements of ISO 23529.

**5.3 Timer**

A stopwatch or other similar device shall be used.

## 6 Calibration

The test apparatus shall be calibrated in accordance with the schedule given in Annex C.

## 7 Test piece

The test piece shall be cylindrical in shape, having a diameter of 17,8 mm  $\pm$  0,15 mm and a height of 25 mm  $\pm$  0,25 mm.

The standard method of preparing the test piece shall be the direct moulding of the cylinder. It is suggested, for the purpose of uniformity and closer tolerance in the moulded test piece, that the dimensions of the mould be specified and shrinkage compensated for therein. A plate cavity of thickness 25,4 mm  $\pm$  0,05 mm and diameter 18,00 mm  $\pm$  0,05 mm, having overflow cavities at both top and bottom when combined with two end plates, provides one type of suitable mould.

An alternative method of preparing the test piece is to cut from a vulcanized slab of the required thickness. The vulcanized thickness shall be such that buffing is not required.

The circular die used for cutting the test piece shall have an inside diameter of 17,8 mm  $\pm$  0,03 mm. In cutting the test piece, the die shall be suitably rotated in a drill press or similar device and lubricated by means of a soap solution. A minimum distance of 13 mm shall be maintained between the cutting edge of the die and the edge of the slab. The cutting pressure shall be as light as possible to minimize cupping or taper in the diameter of the test piece.

It should be recognized that equal time and temperature used for both moulded and slab test pieces do not produce an equivalent state of vulcanization in the two types of test piece. A higher degree of vulcanization is obtained in the moulded test piece. Adjustments, preferably in the time of cure, should be taken into consideration if comparisons between the two types of test piece are to be considered valid.

ISO 4666-3:2010

<https://standards.iteh.ai/catalog/standards/sist/c31e4b7f-850d-495c-a439-bea2088d6fd7/iso-4666-3-2010>

## 8 Test conditions

The conditions specified in Table 1 are normally employed in flexometer tests with constant-strain amplitude.

**Table 1 — Test conditions**

Conditions	Nominal value
Chamber temperature	55 °C $\pm$ 1 °C or 100 °C $\pm$ 1 °C
Stroke (double amplitude)	4,45 mm, 5,71 mm or 6,35 mm
Pre-stress on test piece <sup>a</sup>	1,0 MPa or 2,0 MPa
<sup>a</sup> A pre-stress of 1,0 MPa is equivalent to a weight on the balance beam of 11 kgf; a pre-stress of 2,0 MPa is equivalent to a weight of 22 kgf.	

Tests with the heating chamber removed are referred to as “room temperature” tests, or tests at standard laboratory temperature. The standard laboratory temperature used shall be specified in the test report.

For the measurement of temperature rise, a chamber temperature of either 55 °C or 100 °C shall be selected with a stroke of 4,45 mm or 5,71 mm. Any of these choices of temperature and stroke can be used with a pre-stress of either 1,0 MPa or 2,0 MPa on the test piece. These choices ordinarily give a temperature rise that is essentially at equilibrium after the normal test duration of 25 min. However, test times longer than 25 min can be selected, if desired, for special test purposes.