

---

---

**Fire containment — Elements of building  
construction —**

**Part 1:  
Ventilation ducts**

*Endiguement du feu — Éléments de construction —*

*Partie 1: Conduits de ventilation*  
**iTeh STANDARD PREVIEW**  
**(standards.iteh.ai)**

ISO 6944-1:2008

<https://standards.iteh.ai/catalog/standards/sist/4fdad442-dd08-49cd-b90d-8f69730bd7fe/iso-6944-1-2008>



**PDF disclaimer**

This PDF file may contain embedded typefaces. In accordance with Adobe's licensing policy, this file may be printed or viewed but shall not be edited unless the typefaces which are embedded are licensed to and installed on the computer performing the editing. In downloading this file, parties accept therein the responsibility of not infringing Adobe's licensing policy. The ISO Central Secretariat accepts no liability in this area.

Adobe is a trademark of Adobe Systems Incorporated.

Details of the software products used to create this PDF file can be found in the General Info relative to the file; the PDF-creation parameters were optimized for printing. Every care has been taken to ensure that the file is suitable for use by ISO member bodies. In the unlikely event that a problem relating to it is found, please inform the Central Secretariat at the address given below.

**iTeh STANDARD PREVIEW**  
**(standards.iteh.ai)**

ISO 6944-1:2008

<https://standards.iteh.ai/catalog/standards/sist/4fdad442-dd08-49cd-b90d-8f69730bd7fe/iso-6944-1-2008>



**COPYRIGHT PROTECTED DOCUMENT**

© ISO 2008

All rights reserved. Unless otherwise specified, no part of this publication may be reproduced or utilized in any form or by any means, electronic or mechanical, including photocopying and microfilm, without permission in writing from either ISO at the address below or ISO's member body in the country of the requester.

ISO copyright office  
Case postale 56 • CH-1211 Geneva 20  
Tel. + 41 22 749 01 11  
Fax + 41 22 749 09 47  
E-mail [copyright@iso.org](mailto:copyright@iso.org)  
Web [www.iso.org](http://www.iso.org)

Published in Switzerland

## Contents

Page

|  |    |
|--|----|
| Foreword.....  | iv |
| Introduction .....                                   | v  |
| 1 Scope .....  | 1  |
| 2 Normative references .....                         | 2  |
| 3 Terms and definitions .....                        | 2  |
| 4 Apparatus .....                                    | 2  |
| 5 Test conditions .....                              | 10 |
| 6 Test specimen .....                                | 10 |
| 7 Installation of test specimen .....                | 13 |
| 8 Conditioning.....                                  | 15 |
| 9 Application of instrumentation.....                | 16 |
| 10 Test procedure .....                              | 22 |
| 11 Performance criteria .....                        | 23 |
| 12 Test report .....                                 | 24 |
| 13 Field of direct application of test results ..... | 25 |
| Annex A (informative) General guidance .....         | 28 |
| Bibliography .....                                   | 32 |

## Foreword

ISO (the International Organization for Standardization) is a worldwide federation of national standards bodies (ISO member bodies). The work of preparing International Standards is normally carried out through ISO technical committees. Each member body interested in a subject for which a technical committee has been established has the right to be represented on that committee. International organizations, governmental and non-governmental, in liaison with ISO, also take part in the work. ISO collaborates closely with the International Electrotechnical Commission (IEC) on all matters of electrotechnical standardization.

International Standards are drafted in accordance with the rules given in the ISO/IEC Directives, Part 2.

The main task of technical committees is to prepare International Standards. Draft International Standards adopted by the technical committees are circulated to the member bodies for voting. Publication as an International Standard requires approval by at least 75 % of the member bodies casting a vote.

Attention is drawn to the possibility that some of the elements of this document may be the subject of patent rights. ISO shall not be held responsible for identifying any or all such patent rights.

ISO 6944-1 was prepared by Technical Committee ISO/TC 92, *Fire safety*, Subcommittee SC 2, *Fire containment*.

This first edition of ISO 6944-1, cancels and replaces ISO 6944:1985, which has been technically revised.

ISO 6944 consists of the following parts, under the general title *Fire containment — Elements of building construction*:

— *Part 1: Ventilation ducts* <https://standards.iteh.ai/catalog/standards/sist/4fdad442-dd08-49cd-b90d-8f69730bd7fe/iso-6944-1-2008>

A Part 2, dealing with kitchen extract ducts, is under development.

## Introduction

The purpose of this test is to measure the ability of a representative duct or duct assembly that is part of an air-distribution system to resist the spread of fire from one fire compartment to another, with fire attack from inside or outside the duct. It is applicable to vertical and horizontal ducts, with or without branches, taking into account joints and exhaust openings, as well as suspension devices and penetration points.

This part of ISO 6944 is very similar to EN 1366-1, but includes an alternative arrangement for testing elbows.

The test measures the length of time during which ducts of specified dimensions, suspended as they normally are in practice, satisfy defined criteria when exposed to fire from either inside or outside the duct.

All ducts inside the furnace are fully restrained in all directions. Outside the furnace, ducts exposed to fire from the outside are tested unrestrained, while ducts exposed to fire from the inside (horizontal only) are tested restrained.

The test takes into account the effect of fire exposure from the outside, where a 300 Pa underpressure is maintained in the duct, as well as the effect of fire entering the ducts under conditions where forced air movement might or might not be present, by maintaining an air velocity of 3 m/s.

Ducts exposed to fire from the inside are supplied with air in a manner that is representative of the “fan off” and “fan on” situations that can arise in practice.

ITC STANDARD PREVIEW  
(standards.iteh.ai)

[ISO 6944-1:2008](https://standards.iteh.ai/catalog/standards/sist/4fdad442-dd08-49cd-b90d-8f69730bd7fe/iso-6944-1-2008)

<https://standards.iteh.ai/catalog/standards/sist/4fdad442-dd08-49cd-b90d-8f69730bd7fe/iso-6944-1-2008>

**iTeh STANDARD PREVIEW**  
**(standards.iteh.ai)**

ISO 6944-1:2008

<https://standards.iteh.ai/catalog/standards/sist/4fdad442-dd08-49cd-b90d-8f69730bd7fe/iso-6944-1-2008>

# Fire containment — Elements of building construction —

## Part 1: Ventilation ducts

**CAUTION** — The attention of all persons concerned with managing and carrying out this fire resistance test is drawn to the fact that fire testing can be hazardous and that there is the possibility that toxic and/or harmful smoke and gases can be evolved during the test. Mechanical and operational hazards can also arise during the construction of the test elements or structures, their testing and disposal of test residues.

It is strongly recommended that the duct assembly be allowed to cool completely after the fire test, before dismantling, to minimize the possibility of ignition of combustible residues.

An assessment of all potential hazards and risks to health shall be made and safety precautions shall be identified and provided. Written safety instructions shall be issued. Appropriate training shall be given to relevant personnel. Laboratory personnel shall ensure that they follow written safety instructions at all times.

STANDARD PREVIEW  
(standards.iteh.ai)

### 1 Scope

ISO 6944-1:2008

This part of ISO 6944 specifies a method for determining the fire resistance of vertical and horizontal ventilation ducts under standardized fire conditions. The test examines the behaviour of ducts exposed to fire from the outside (duct A) and fire inside the duct (duct B). It is intended that this part of ISO 6944 be used in conjunction with ISO 834-1.

This part of ISO 6944 is not applicable to

- a) ducts whose fire resistance depends on the fire resistance performance of a ceiling,
- b) ducts containing fire dampers at points where they pass through fire separations,
- c) doors of inspection openings, unless included in the duct to be tested,
- d) two- or three-sided ducts,
- e) the fixing of suspension devices to floors or walls.

NOTE Annex A provides general guidance and gives background information.

## 2 Normative references

The following referenced documents are indispensable for the application of this document. For dated references, only the edition cited applies. For undated references, the latest edition of the referenced document (including any amendments) applies.

ISO 834-1, *Fire-resistance tests — Elements of building construction — Part 1: General requirements*

ISO 5167-1, *Measurement of fluid flow by means of pressure differential devices inserted in circular cross-section conduits running full — Part 1: General principles and requirements*

ISO 5221, *Air distribution and air diffusion — Rules to methods of measuring air flow rate in an air handling duct*

ISO 13943, *Fire safety — Vocabulary*

## 3 Terms and definitions

For the purposes of this document, the terms and definitions given in ISO 834-1 and ISO 13943, and the following apply.

### 3.1

#### **fire resisting duct**

duct used for the distribution or extraction of air and designed to provide a degree of fire resistance

### 3.2

#### **suspension device**

components used for supporting and fixing a duct from a floor or supporting a duct from a wall

### 3.3

#### **supporting devices**

wall, partition or floor through which the duct passes during the test

### 3.4

#### **compensator**

device that is used to prevent damage from the forces generated by expansion

## 4 Apparatus

4.1 In addition to the test equipment specified in ISO 834-1, the following apparatus is required.

4.2 **Furnace**, capable of subjecting ventilation ducts to the standard heating conditions specified in ISO 834-1 and suitable for testing ducts in the vertical (see Figure 1) or horizontal (see Figure 2) orientation.

Figures 1 and 2 show two ducts being tested together. When two ducts are tested together, they shall be separated by a minimum of 500 mm. It is also permitted to test each duct singularly in the furnace.

4.3 **Fan A**, capable of producing an underpressure of  $(300 \pm 15)$  Pa within duct A (see Figure 3) at the start and throughout the test, and shall be connected, either directly or by a suitable length of flexible ducting, to the measuring station (4.5).

4.4 **Fan B**, capable of producing an air velocity when extracting gas from duct B (see Figure 4) of at least 3 m/s measured at ambient temperature in the duct before the test.

It shall be connected, either directly or by a suitable length of flexible ducting, to the velocity-measuring station (4.8). The fan shall be provided with a by-pass vent that can be opened prior to shutting the damper (4.7).



Dimensions in millimetres

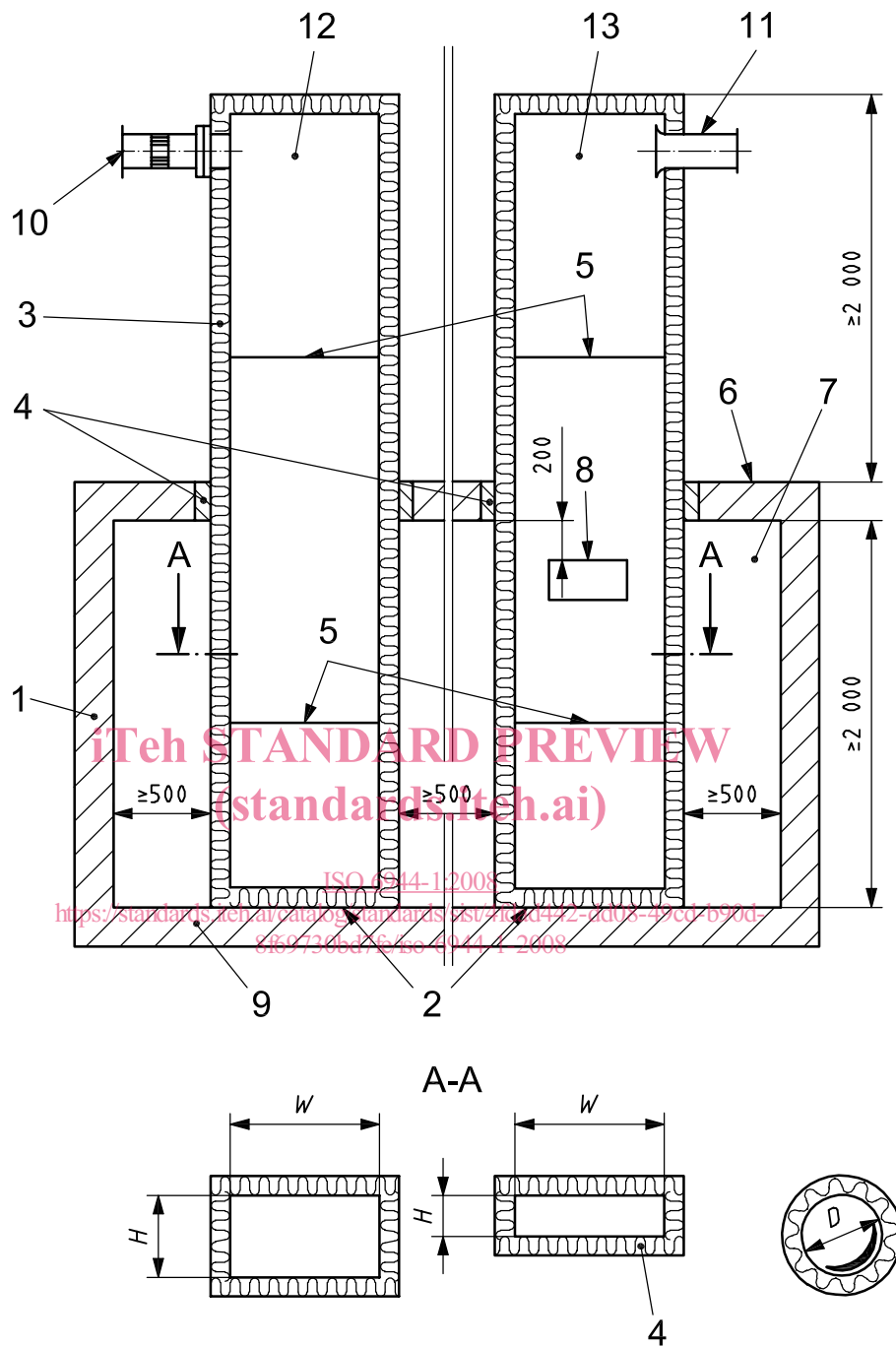

**Key**

- |   |  |    |  |
|---|--|----|--|
| 1 | furnace wall                                 | 7  | furnace chamber  |
| 2 | sealed end                                   | 8  | openings providing a total area of 50% of duct cross-section |
| 3 | fire-protection system                       | 9  | furnace floor  |
| 4 | location for fire stopping (normal practice) | 10 | leakage-measuring station (see Figure 3 for details)         |
| 5 | joint in fire-protection system              | 11 | gas-velocity-measuring station (see Figure 4 for details)    |
| 6 | furnace roof                                 | 12 | duct A   |
|   |  | 13 | duct B   |

*W* width  
*H* height  
*D* diameter

See 4.2.

**Figure 1 — Test arrangement for vertical ducts**

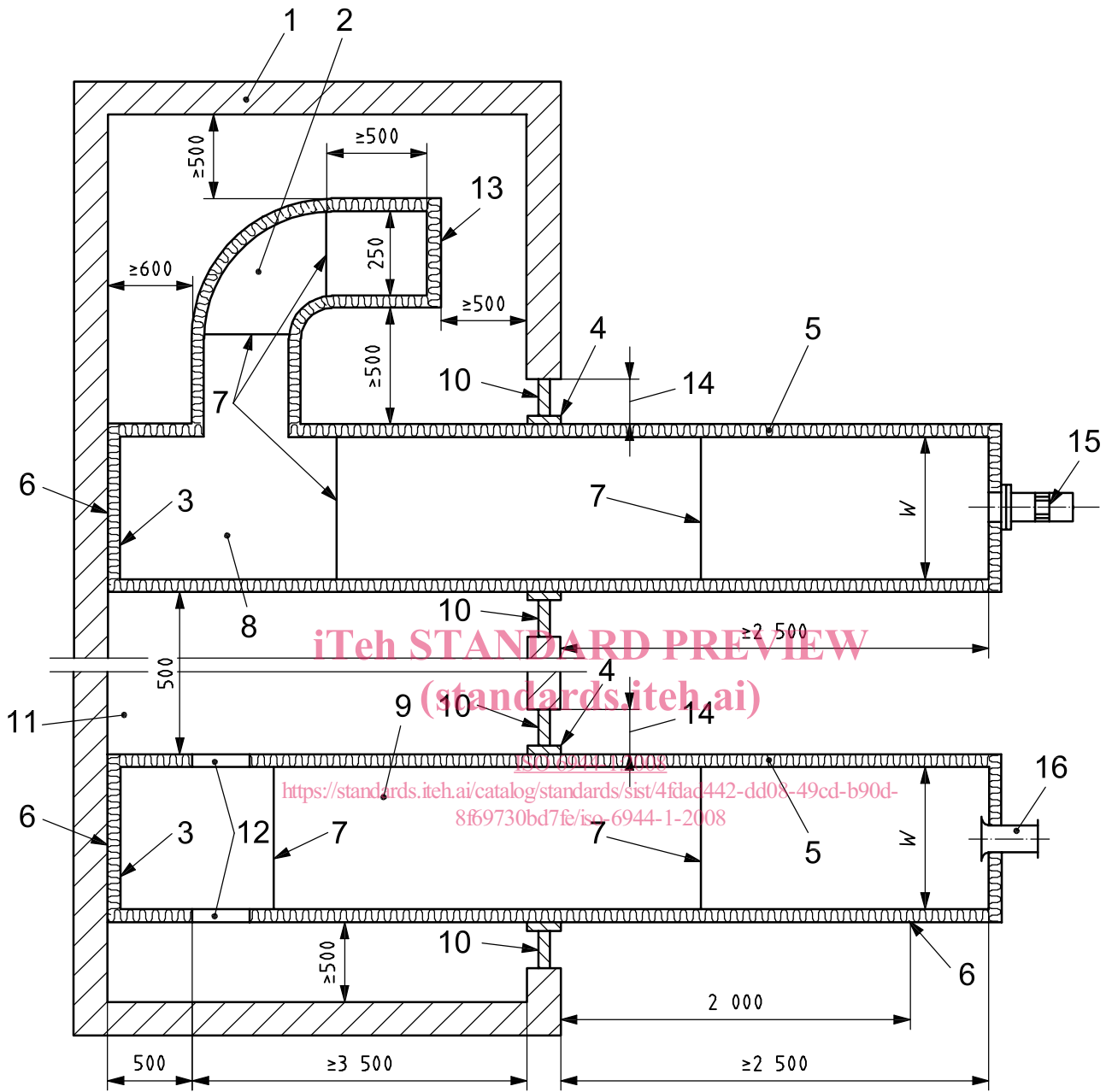

**Key**

- |   |  |    |   |
|---|--|----|---|
| 1 | furnace wall                                 | 9  | duct B  |
| 2 | duct with 90° elbow                          | 10 | supporting construction                                       |
| 3 | sealed end                                   | 11 | furnace chamber   |
| 4 | location for fire stopping (normal practice) | 12 | openings providing a total area of 50 % of duct cross-section |
| 5 | fire-protection system                       | 13 | sealed end of elbow   |
| 6 | location of restraint positions              | 14 | 200 mm minimum supporting construction                        |
| 7 | joints in fire-protection system             | 15 | leakage-measuring station (see Figure 3 for details)          |
| 8 | duct A                                       | 16 | gas-velocity-measuring station (see Figure 4 for details)     |

W width or diameter

See 4.2.

**Figure 2 — Test arrangement for horizontal ducts**

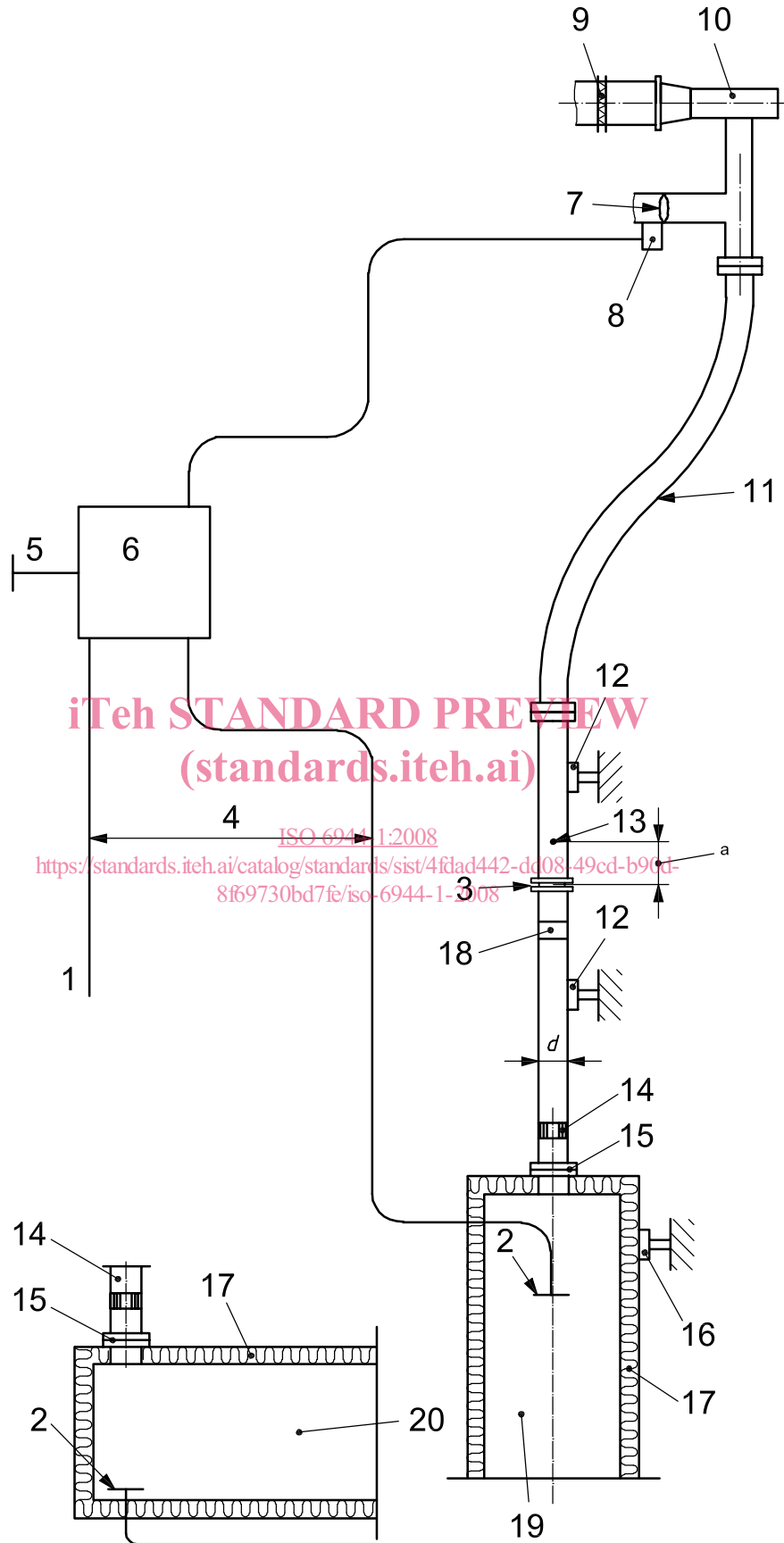

iTeh STANDARD PREVIEW  
 (standards.iteh.ai)  
 ISO 6944-1:2008  
<https://standards.iteh.ai/catalog/standards/sist/4fdad442-dd08-49cd-b96d-8f69730bd7fe/iso-6944-1-2008>

Figure 3 (continued)

**Key**

|    |  |    |                                     |
|----|--|----|-------------------------------------|
| 1  | pressure sensor to furnace             | 11 | flexible connecting duct            |
| 2  | pressure sensor on centre-line of duct | 12 | support for flow-measuring system   |
| 3  | orifice plate, venturi or similar      | 13 | thermocouple, 1,5 mm diameter       |
| 4  | pressure differential of 300 Pa        | 14 | flow straightener (where necessary) |
| 5  | pressure sensor in laboratory          | 15 | flange                              |
| 6  | pressure-differential control box      | 16 | support for duct outside furnace    |
| 7  | pressure-control dilution damper       | 17 | test duct                           |
| 8  | pneumatic-actuator manual control      | 18 | condensing device                   |
| 9  | balancing damper                       | 19 | horizontal duct A                   |
| 10 | fan                                    | 20 | vertical duct A                     |

<sup>a</sup> Thermocouple located  $2d$  from key item 3; see Note.

NOTE  $d$  is the diameter of the measuring duct downstream from the flow-measuring device.

**Figure 3 — Leakage-measuring station for duct A**

**iTeh STANDARD PREVIEW**  
**(standards.iteh.ai)**

[ISO 6944-1:2008](https://standards.iteh.ai/catalog/standards/sist/4fdad442-dd08-49cd-b90d-8f69730bd7fe/iso-6944-1-2008)

<https://standards.iteh.ai/catalog/standards/sist/4fdad442-dd08-49cd-b90d-8f69730bd7fe/iso-6944-1-2008>

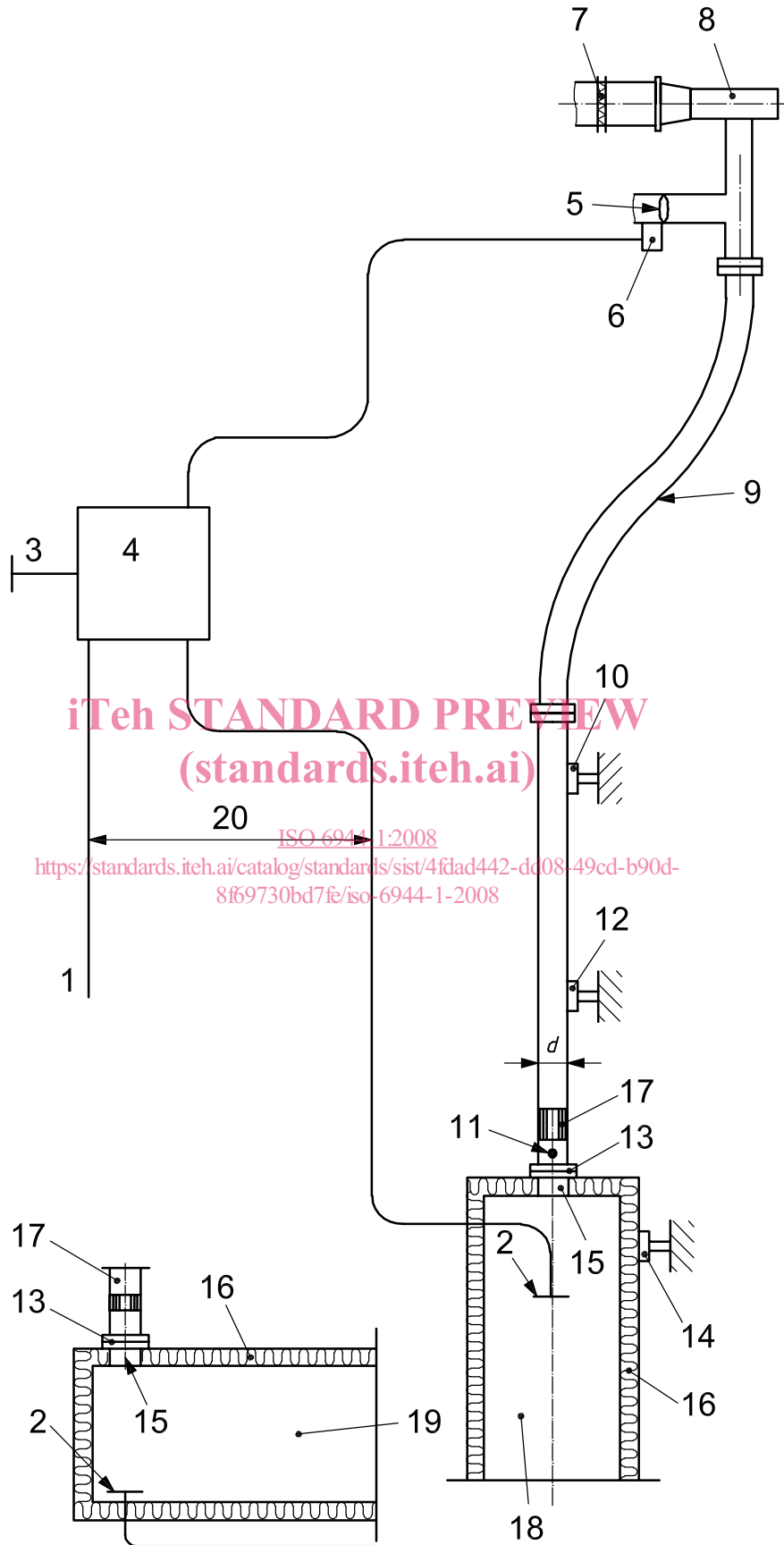

Figure 4 (continued)