INTERNATIONAL STANDARD**766**

INTERNATIONAL ORGANIZATION FOR STANDARDIZATION • МЕЖДУНАРОДНАЯ ОРГАНИЗАЦИЯ ПО СТАНДАРТИЗАЦИИ • ORGANISATION INTERNATIONALE DE NORMALISATION

Fibre building boards – Determination of dimensions of test pieces

First edition – 1972-09-01

iTeh STANDARD PREVIEW
(standards.iteh.ai)

ISO 766:1972

<https://standards.iteh.ai/catalog/standards/sist/7d3e0081-e3ad-46a1-a3b6-a3403d1e7b18/iso-766-1972>

UDC 674.817-41

Ref. No. ISO 766-1972 (E)

Descriptors : building boards, fibreboards, test specimens, measurement, dimensions.

Price based on 2 pages

FOREWORD

ISO (the International Organization for Standardization) is a worldwide federation of national standards institutes (ISO Member Bodies). The work of developing International Standards is carried out through ISO Technical Committees. Every Member Body interested in a subject for which a Technical Committee has been set up has the right to be represented on that Committee. International organizations, governmental and non-governmental, in liaison with ISO, also take part in the work.

Draft International Standards adopted by the Technical Committees are circulated to the Member Bodies for approval before their acceptance as International Standards by the ISO Council.

International Standard ISO 766 was drawn up by Technical Committee ISO/TC 89, *Fibre building boards*.

This International Standard is the revision of ISO Recommendation R 766-1968. As the Members of ISO/TC 89 considered the amendments made to that ISO Recommendation to be of minor importance, International Standard ISO 766 was submitted direct to the ISO Council under the abbreviated procedure (ISO Directives, Clause F.7.1).

This International Standard cancels and replaces ISO Recommendation R 766-1968, which was approved in October 1965 by the Member Bodies of the following countries :

Argentina	Germany	Romania
Australia	Hungary	South Africa, Rep. of
Austria	India	Spain
Belgium	Ireland	Sweden
Brazil	Israel	Switzerland
Canada	Japan	United Kingdom
Czechoslovakia	Netherlands	U.S.S.R.
Egypt, Arab Rep. of	New Zealand	Yugoslavia
Finland	Poland	
France	Portugal	

No Member Body expressed disapproval of the document.

Fibre building boards – Determination of dimensions of test pieces

1 SCOPE AND FIELD OF APPLICATION

This International Standard specifies a method for measuring the thickness, length and width of test pieces of fibre building boards, defined in ISO/R 818.

4.3 The test pieces shall be conditioned to constant mass¹⁾ in an atmosphere of a relative humidity of $65 \pm 5\%$ and a temperature of $20 \pm 2^\circ\text{C}$.

2 REFERENCES

ISO/R 818, *Fibre building boards – Definition – Classification*.

ISO . . ., *Fibre building boards – Sampling, cutting and inspection*. (In preparation.)

5 PROCEDURE

5.1 For measuring the thickness, the measuring surfaces of the micrometer shall be applied slowly to the test piece and at a pressure of approximately 0.02 N/mm^2 .

5.2 For measuring the length and width, the jaw of the sliding caliper shall be applied slowly to the test piece at an angle of approximately 45° to the plane of the test piece (see Figure).

5.3 The number and position of the measuring points shall be in accordance with the ISO publications concerning each testing method of fibre building boards.

3 APPARATUS

3.1 **Micrometer**, having flat and parallel circular measuring surfaces of $16 \pm 1\text{ mm}$ (approximately 200 mm^2) diameter. The graduation of the apparatus shall allow a reading

- to an accuracy of 0.01 mm for test pieces of hard and medium boards;
- to an accuracy of 0.1 mm for test pieces of soft boards.

3.2 **Sliding caliper**, or any other instrument with measuring surfaces of at least 5 mm width, and graduated to allow a reading to an accuracy of 0.1 mm .

3.3 **Balance**, allowing a reading to an accuracy of 0.01 g .

4 SAMPLING AND CONDITIONING OF TEST PIECES

4.1 Sampling and cutting of the test pieces shall be carried out in accordance with ISO . . .

4.2 The dimensions of the test pieces shall be in accordance with those specified in the relevant test method.

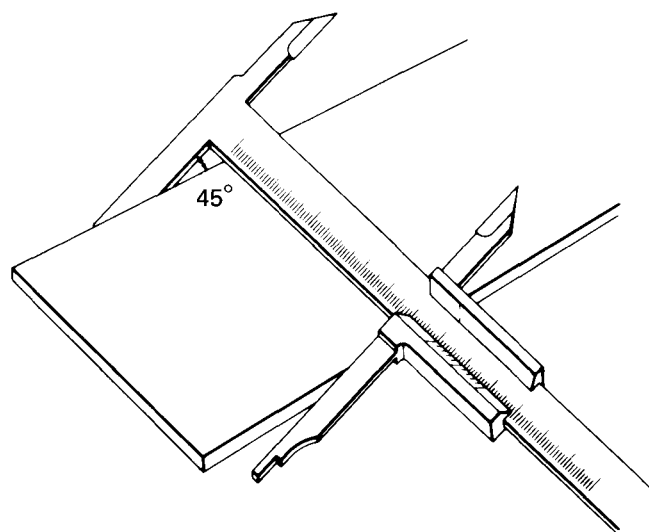

1) Constant mass is considered to be reached when the results of two successive weighing operations, carried out at an interval of 24 h, do not differ by more than 0.1 % of the mass of the test piece.

6 CALCULATION AND EXPRESSION OF RESULTS

6.1 The result of each of the measurements shall be expressed as follows :

a) *Thickness*

for test pieces of hard and medium boards

- with a thickness ≤ 7 mm, to the nearest 0.01 mm
- with a thickness > 7 mm, to the nearest 0.05 mm

for test pieces of soft boards of all thicknesses, to the nearest 0.1 mm.

b) *Length and width*

- for test pieces for medium and hard boards, to the nearest 0.1 mm
- for soft boards, to the nearest 0.5 mm.

6.2 For determination of thickness, length and width of the test piece, the mean arithmetical value of each group of measurements shall be stated in millimetres, rounded to the same accuracy as given in 6.1 a) and 6.1 b) respectively.

7 TEST REPORT

See the ISO publications concerning each particular testing method.

iTeh STANDARD PREVIEW
(standards.iteh.ai)

ISO 766:1972

<https://standards.iteh.ai/catalog/standards/sist/7d3e0081-e3ad-46a1-a3b6-a3403d1e7b18/iso-766-1972>