



Designation: D 3838 – 80 (Reapproved 1999)

## Standard Test Method for pH of Activated Carbon<sup>1</sup>

This standard is issued under the fixed designation D 3838; the number immediately following the designation indicates the year of original adoption or, in the case of revision, the year of last revision. A number in parentheses indicates the year of last reapproval. A superscript epsilon ( $\epsilon$ ) indicates an editorial change since the last revision or reapproval.

### 1. Scope

1.1 This test method covers determination of the pH of a water extract of activated carbon.

1.2 *This standard does not purport to address all of the safety concerns, if any, associated with its use. It is the responsibility of the user of this standard to establish appropriate safety and health practices and determine the applicability of regulatory limitations prior to use.* For specific hazard statements, see Section 6.

### 2. Referenced Documents

#### 2.1 ASTM Standards:

D 1193 Specification for Reagent Water<sup>2</sup>

D 1293 Test Methods for pH of Water<sup>2</sup>

D 2867 Test Method for Moisture in Activated Carbon<sup>3</sup>

E 300 Practice for Sampling Industrial Chemicals<sup>4</sup>

### 3. Summary of Test Method

3.1 An activated carbon sample is boiled in reagent water using a reflux condenser to recycle water vapor. The particles of carbon are filtered out, the filtrate cooled to 50°C and the pH of the filtrate determined by electrometric measurement.

### 4. Significance and Use

4.1 When a fluid containing an adsorbate is passed through a bed of activated carbon, chemical reactions may take place between the activated carbon, its other noncarbonaceous constituents, and the adsorbate containing fluid. The pH of the carbon may be a significant parameter of such a reaction and therefore may be an important characteristic of the carbon.

### 5. Apparatus and Materials

5.1 *Analytical Balance*, capacity 100 g, precision  $\pm 0.01$  g.

5.2 *Hot Plate*.

5.3 *Glassware for Boiler-Reflux Condenser Apparatus* (Fig. 1)—Items shown are for guidance only, providing a convenient set of equipment available off-the-shelf from many laboratory

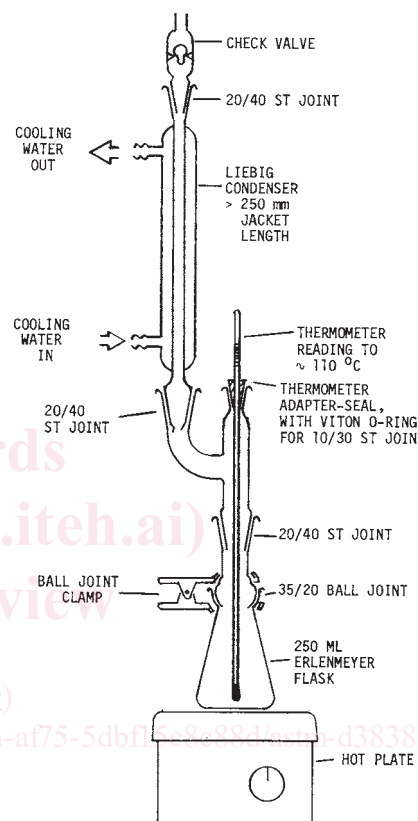

FIG. 1 Boiler-Reflux Condenser Apparatus

supply houses. The “all-glass” elements, with standard-taper and ball joints, provide freedom from contamination and maintenance. A check valve in the position shown is essential to relieve pressure buildup while minimizing loss of vapor.

5.4 *Thermometer*, glass, approximately 0 to 120°C, long enough to be read at 100°C when inserted to bottom of Erlenmeyer flask in Fig. 1.

5.5 *Thermometer*, glass, approximately 20 to 55°C.

5.6 *Graduated Cylinder*, 100-mL.

5.7 *Beaker*, 200-mL.

5.8 *Filter Funnel*.

5.9 *Filter Paper*, qualitative, medium flow rate, 12.5 cm or larger in diameter.

5.10 *Timer*.

5.11 *pH Meter*, in accordance with Test Methods D 1293, Type II (automatic thermal compensation preferred).

<sup>1</sup> This test method is under the jurisdiction of ASTM Committee D-28 on Activated Carbon and is the direct responsibility of Subcommittee D28.04 on Gas Phase Evaluation Tests.

Current edition approved Jan. 3, 1980. Published March 1980.

<sup>2</sup> *Annual Book of ASTM Standards*, Vol 11.01.

<sup>3</sup> *Annual Book of ASTM Standards*, Vol 15.01.

<sup>4</sup> *Annual Book of ASTM Standards*, Vol 15.05.