

---

---

**Paints and varnishes — Drying tests —  
Part 2:  
Pressure test for stackability**

*Peintures et vernis — Essais de séchage —*

*Partie 2: Essai de pression pour aptitude à l'empilement*

**iTeh STANDARD PREVIEW**  
**(standards.iteh.ai)**

ISO 9117-2:2010

<https://standards.iteh.ai/catalog/standards/sist/703979c4-9f15-423a-938e-5a0a4ec743aa/iso-9117-2-2010>



**PDF disclaimer**

This PDF file may contain embedded typefaces. In accordance with Adobe's licensing policy, this file may be printed or viewed but shall not be edited unless the typefaces which are embedded are licensed to and installed on the computer performing the editing. In downloading this file, parties accept therein the responsibility of not infringing Adobe's licensing policy. The ISO Central Secretariat accepts no liability in this area.

Adobe is a trademark of Adobe Systems Incorporated.

Details of the software products used to create this PDF file can be found in the General Info relative to the file; the PDF-creation parameters were optimized for printing. Every care has been taken to ensure that the file is suitable for use by ISO member bodies. In the unlikely event that a problem relating to it is found, please inform the Central Secretariat at the address given below.

**iTeh STANDARD PREVIEW**  
**(standards.iteh.ai)**

ISO 9117-2:2010

<https://standards.iteh.ai/catalog/standards/sist/703979c4-9f15-423a-938e-5a0a4ec743aa/iso-9117-2-2010>



**COPYRIGHT PROTECTED DOCUMENT**

© ISO 2010

All rights reserved. Unless otherwise specified, no part of this publication may be reproduced or utilized in any form or by any means, electronic or mechanical, including photocopying and microfilm, without permission in writing from either ISO at the address below or ISO's member body in the country of the requester.

ISO copyright office  
Case postale 56 • CH-1211 Geneva 20  
Tel. + 41 22 749 01 11  
Fax + 41 22 749 09 47  
E-mail [copyright@iso.org](mailto:copyright@iso.org)  
Web [www.iso.org](http://www.iso.org)

Published in Switzerland

## Foreword

ISO (the International Organization for Standardization) is a worldwide federation of national standards bodies (ISO member bodies). The work of preparing International Standards is normally carried out through ISO technical committees. Each member body interested in a subject for which a technical committee has been established has the right to be represented on that committee. International organizations, governmental and non-governmental, in liaison with ISO, also take part in the work. ISO collaborates closely with the International Electrotechnical Commission (IEC) on all matters of electrotechnical standardization.

International Standards are drafted in accordance with the rules given in the ISO/IEC Directives, Part 2.

The main task of technical committees is to prepare International Standards. Draft International Standards adopted by the technical committees are circulated to the member bodies for voting. Publication as an International Standard requires approval by at least 75 % of the member bodies casting a vote.

Attention is drawn to the possibility that some of the elements of this document may be the subject of patent rights. ISO shall not be held responsible for identifying any or all such patent rights.

ISO 9117-2 was prepared by Technical Committee ISO/TC 35, *Paints and varnishes*, Subcommittee SC 9, *General test methods for paints and varnishes*.

This first edition of ISO 9117-2 cancels and replaces ISO 4622:1992, which has been technically revised. The main changes are as follows:

- iTeh STANDARD PREVIEW**  
(standards.iteh.ai)
- a) the method has been integrated into the ISO 9117 series as Part 2, for determination of the drying of paints and varnishes;  
<https://standards.iteh.ai/catalog/standards/sist/703979c4-9f15-423a-938e-5a04ec743a/iso-9117-2-2010>
  - b) a “terms and definitions” clause has been added;
  - c) a “principle” clause has been added;
  - d) the requirement for relative humidity during the procedure has been deleted, i.e. it is not necessary to carry out the test in a climate chamber;
  - e) text from the former annex A headed “required supplementary information” has been integrated into the test report.

ISO 9117 consists of the following parts, under the general title *Paints and varnishes — Drying tests*:

- *Part 1: Determination of through-dry state and through-dry time*
- *Part 2: Pressure test for stackability*
- *Part 3: Surface-drying test using ballotini*

The following parts are under preparation:

- *Part 4: Test using a mechanical recorder*
- *Part 5: Modified Bandow-Wolff test*

**iTeh STANDARD PREVIEW**  
**(standards.iteh.ai)**

ISO 9117-2:2010

<https://standards.iteh.ai/catalog/standards/sist/703979c4-9f15-423a-938e-5a0a4ec743aa/iso-9117-2-2010>

# Paints and varnishes — Drying tests —

## Part 2: Pressure test for stackability

### 1 Scope

This part of ISO 9117 specifies a test method for determining, under standard conditions, whether a single-coat film or a multi-coat system of paints or related materials, after a specified drying period, is sufficiently dry to resist damage when two painted surfaces or one painted surface and another surface are placed in contact under pressure.

The method is intended to simulate the conditions when painted articles are stacked upon each other.

NOTE In some countries, the test is called a “block resistance” test.

iTeh STANDARD PREVIEW

### 2 Normative references (standards.iteh.ai)

The following referenced documents are indispensable for the application of this document. For dated references, only the edition cited applies. For undated references, the latest edition of the referenced document (including any amendments) applies.

ISO 1513, *Paints and varnishes — Examination and preparation of test samples*

ISO 1514, *Paints and varnishes — Standard panels for testing*

ISO 2808, *Paints and varnishes — Determination of film thickness*

ISO 3270, *Paints and varnishes and their raw materials — Temperatures and humidities for conditioning and testing*

ISO 15528, *Paints, varnishes and raw materials for paints and varnishes — Sampling*

### 3 Terms and definitions

For the purposes of this document, the following terms and definitions apply.

#### 3.1

##### **stackability**

resistance to damage due to unwanted adhesion between adjacent surfaces of articles that develops when these articles are left in contact

## 4 Principle

A coat of paint or varnish is applied to a substrate and is allowed to dry under specified conditions. The coated test panel is cut into strips, and two strips are placed so that the test surfaces are in close contact. This assembly is placed in a test apparatus and loaded with weights. After a specified period of time, the panels are examined for any damage to the coating in the area of contact.

## 5 Apparatus

**5.1 Test apparatus**, e.g. as shown in Figure 1, consisting of a baseplate and a free-sliding plunger. The plunger, with a head of diameter  $(50 \pm 1)$  mm, shall have a mass of  $(250 \pm 2)$  g and be designed in such a way that the face of the plunger is aligned with the top surface of the test panel.

It is recommended that a ball joint connection be present between the plunger and its head.

**5.2 Weights**, of mass in the range 100 g to 1 000 g.

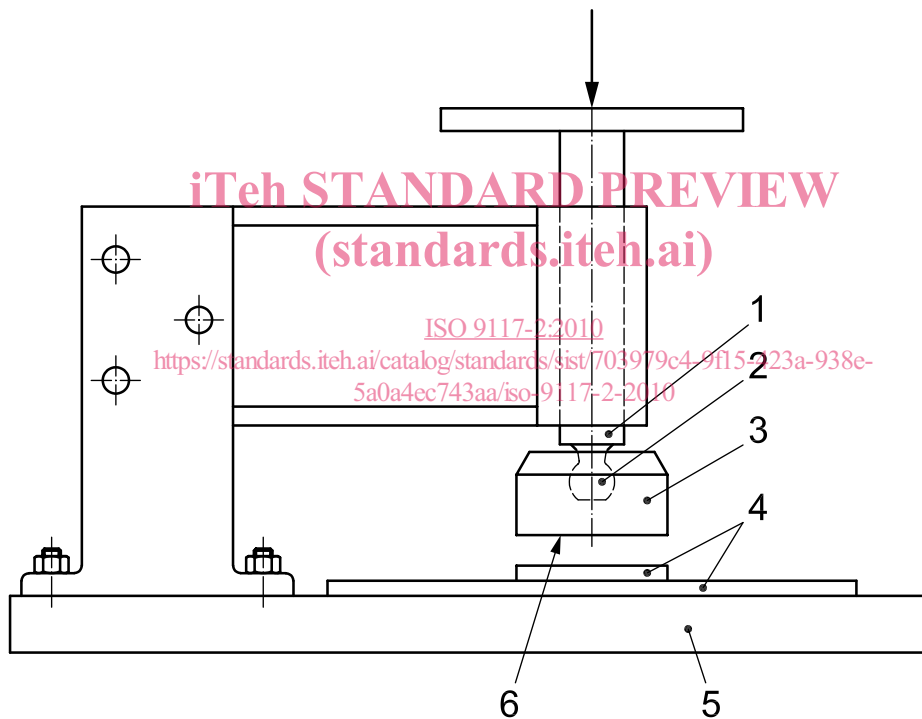

- Key**
- 1 plunger
  - 2 ball joint
  - 3 head
  - 4 test panels
  - 5 baseplate
  - 6 face

Figure 1 — Example of suitable test apparatus

## 6 Sampling

Take a representative sample of the product to be tested (or of each product in the case of a multi-coat system) in accordance with ISO 15528.

Examine and prepare each sample for testing in accordance with ISO 1513.

## 7 Test panels

### 7.1 Substrate

Select the substrate from one of those described in ISO 1514 and, where possible, in accordance with the intended practical application.

### 7.2 Preparation and coating

Prepare each test panel (see 7.1) in accordance with ISO 1514 and then coat it by the specified method with the product or system under test.

### 7.3 Drying

Dry (or stove) and age, if applicable, each coated test panel in a horizontal position with free circulation of air, but shielded from draughts and direct sunlight, for the specified time under the specified conditions.

### 7.4 Preparation of test pieces (standards.iteh.ai)

As soon as possible after the specified drying period, prepare from the test panels at least six strips of width  $l = (30 \pm 1)$  mm and length approximately five times the width, in such a manner as to: avoid damage to the paint film; produce the least distortion of the substrate; and ensure that it remains as planar as possible.

Remove any rim raised on the test pieces before testing.

If the preparation of appropriate test pieces with dimensions as given above is unfeasible, because the coating to be tested can be easily damaged, test pieces may be used of dimensions up to 100 mm × 75 mm. In this case, Clause 9 shall be applied.

If the interaction between the painted surface and another surface is to be determined, prepare a similar test piece of the other material.

### 7.5 Thickness of coating

Determine the thickness, in micrometres, of the dried coating by one of the procedures specified in ISO 2808.

## 8 Procedure

**8.1** Carry out the procedure in triplicate at standard temperature  $(23 \pm 2)$  °C and ambient relative humidity (see ISO 3270). The relative humidity during the test shall be measured and stated in the test report.

**8.2** Superpose the test pieces at  $(90 \pm 2)$ ° so that the test surfaces facing each other are in close contact (see plan view in Figure 2). Arrange the test pieces so that the areas least damaged during preparation are superposed.

NOTE A set square may be used to ensure that the test area is square.

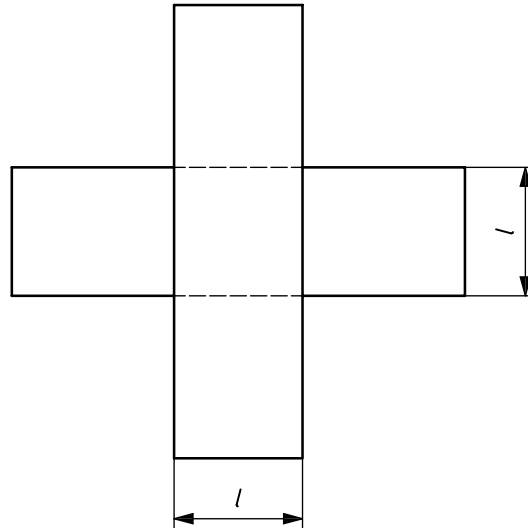

**Key**

*l* width of the square of the overlapping test pieces in contact (see 7.4)

NOTE The length of the test piece is approximately five times the width (see 7.4).

**Figure 2 — Plan view of typical arrangement of test pieces**

**8.3** Place the test pieces on the baseplate in such a manner that the plunger covers the contact square entirely. Place the weight on the plunger and gently place the total mass in contact with the test pieces. Allow it to remain there for the specified time. The weight and the time of contact under load have to be specified between the interested parties.

**8.4** At the end of this period, remove the plunger, separate the test pieces and examine them for any damage to the coating in the area of contact, e.g. the presence of visible impressions, any sticking of the test pieces, and any detachment of the coating. The time elapsed between removal of the weights and examination shall be stated in the test report.

**8.5** Repeat the procedure in 8.2 to 8.4 on two additional test arrangements.

**9 Calculation of pressure**

The pressure, *p*, in pascals, on the painted surfaces may be calculated from the following equation:

$$p = \frac{m_1 + m_2 + m_3}{l^2} g \times 10^3$$

$$\approx \frac{m_1 + m_2 + m_3}{l^2} \times 10^4$$

where

*m*<sub>1</sub> is the mass, in grams, of the plunger assembly;

*m*<sub>2</sub> is the mass, in grams, of the weight;

*m*<sub>3</sub> is the mass, in grams, of the upper test piece;

*l* is the width, in millimetres, of the square of the overlapping test pieces in contact (see Figure 2);

*g* is the acceleration of free fall, in newtons per kilogram (approximately 10 N/kg).



## 10 Precision

No precision data are currently available.

## 11 Test report

The test report shall include at least the following information:

- a) all details necessary to identify the product or the system under test;
- b) a reference to this part of ISO 9117 (ISO 9117-2:2010);
- c) details of the preparation of the test panels, including
  - 1) the material (including thickness) and surface preparation of the substrate (see 7.1),
  - 2) the method of application of the test coating to the substrate, including duration and conditions of drying between coats in the case of a multi-coat system (see 7.2),
  - 3) the duration and conditions of drying (or stoving) and ageing (if applicable) the coat before testing (see 7.3),
  - 4) the thickness, in micrometres, of the dry coating and method of measurement in accordance with ISO 2808, and whether it is a single coat or a multi-coat system (see 7.5);
- d) relative humidity during the test (see 8.1);
- e) the combined mass of the plunger and weight (i.e. test load) or the pressure to be used (see 8.3);
- f) the duration of contact under load of the two pieces (see 8.3);
- g) the time elapsed between removal of the weights and examination (see 8.4);
- h) the results of the test in terms of the stated requirements and a description of any damage (see 8.4);
- i) any unusual features (anomalies) observed during the test;
- j) any deviations from the test procedure specified;
- k) the date of the test.