

---

---

**Paints and varnishes — Rapid-  
deformation (impact resistance) tests —**

Part 2:

**Falling-weight test, small-area indenter**

*Peintures et vernis — Essais de déformation rapide (résistance au  
choc) —*

iTeh STANDARD PREVIEW

*Partie 2: Essai de chute d'une masse avec pénétrateur de surface  
réduite*

(standards.iteh.ai)

ISO 6272-2:2011

<https://standards.iteh.ai/catalog/standards/sist/73b5a42a-814b-4297-bcd0-9147a3057db2/iso-6272-2-2011>



**iTeh STANDARD PREVIEW**  
**(standards.iteh.ai)**

ISO 6272-2:2011

<https://standards.iteh.ai/catalog/standards/sist/73b5a42a-814b-4297-bcd0-9147a3057db2/iso-6272-2-2011>



**COPYRIGHT PROTECTED DOCUMENT**

© ISO 2011

All rights reserved. Unless otherwise specified, no part of this publication may be reproduced or utilized in any form or by any means, electronic or mechanical, including photocopying and microfilm, without permission in writing from either ISO at the address below or ISO's member body in the country of the requester.

ISO copyright office  
Case postale 56 • CH-1211 Geneva 20  
Tel. + 41 22 749 01 11  
Fax + 41 22 749 09 47  
E-mail [copyright@iso.org](mailto:copyright@iso.org)  
Web [www.iso.org](http://www.iso.org)

Published in Switzerland

**Contents**

Page

Foreword .....	iv
<b>1</b> <b>Scope</b> .....	<b>1</b>
<b>2</b> <b>Normative references</b> .....	<b>1</b>
<b>3</b> <b>Principle</b> .....	<b>1</b>
<b>4</b> <b>Apparatus</b> .....	<b>2</b>
<b>5</b> <b>Reagents</b> .....	<b>2</b>
<b>6</b> <b>Sampling</b> .....	<b>2</b>
<b>7</b> <b>Test panels</b> .....	<b>2</b>
<b>8</b> <b>Procedure</b> .....	<b>4</b>
<b>9</b> <b>Precision</b> .....	<b>5</b>
<b>10</b> <b>Test report</b> .....	<b>5</b>

**iTeh STANDARD PREVIEW**  
**(standards.iteh.ai)**

[ISO 6272-2:2011](https://standards.iteh.ai/catalog/standards/sist/73b5a42a-814b-4297-bcd0-9147a3057db2/iso-6272-2-2011)

<https://standards.iteh.ai/catalog/standards/sist/73b5a42a-814b-4297-bcd0-9147a3057db2/iso-6272-2-2011>

## Foreword

ISO (the International Organization for Standardization) is a worldwide federation of national standards bodies (ISO member bodies). The work of preparing International Standards is normally carried out through ISO technical committees. Each member body interested in a subject for which a technical committee has been established has the right to be represented on that committee. International organizations, governmental and non-governmental, in liaison with ISO, also take part in the work. ISO collaborates closely with the International Electrotechnical Commission (IEC) on all matters of electrotechnical standardization.

International Standards are drafted in accordance with the rules given in the ISO/IEC Directives, Part 2.

The main task of technical committees is to prepare International Standards. Draft International Standards adopted by the technical committees are circulated to the member bodies for voting. Publication as an International Standard requires approval by at least 75 % of the member bodies casting a vote.

Attention is drawn to the possibility that some of the elements of this document may be the subject of patent rights. ISO shall not be held responsible for identifying any or all such patent rights.

ISO 6272-2 was prepared by Technical Committee ISO/TC 35, *Paints and varnishes*, Subcommittee SC 9, *General test methods for paints and varnishes*.

This second edition cancels and replaces the first edition (ISO 6272-2:2002), which has been technically revised. The main technical changes are: **(standards.iteh.ai)**

- a) all non-SI units have been deleted;
- b) the definition has been deleted because the term "impact" is incorrect for this test, <https://standards.iteh.ai/catalog/standards/sist/73b5a42a-814b-4297-bcd0-9147a3057db2/iso-6272-2-2011>
- c) a figure showing the test apparatus has been added;
- d) the test is no longer carried out at a specified relative humidity; instead, the relative humidity is simply recorded but the test has to be completed within a specified length of time after conditioning the test panels;
- e) a pin-hole detector is no longer used to detect holes in the coating under test;
- f) the precision data have been deleted because the method is slightly different from the ASTM method to which the precision data applied;
- g) the supplementary test conditions (formerly Annex A) have been incorporated in the test report.

ISO 6272 consists of the following parts, under the general title *Paints and varnishes — Rapid-deformation (impact resistance) tests*:

- *Part 1: Falling-weight test, large-area indenter*
- *Part 2: Falling-weight test, small-area indenter*

# Paints and varnishes — Rapid-deformation (impact resistance) tests —

## Part 2: Falling-weight test, small-area indenter

### 1 Scope

This part of ISO 6272 describes a method for evaluating the resistance of a dry film of paint, varnish or related product to cracking or peeling from a substrate when it is subjected to a deformation caused by a falling weight, dropped under standard conditions, acting on a small-area spherical indenter.

NOTE The terms “impact” and “impact resistance” are used in the title and text of this part of ISO 6272, but an important characteristic of the apparatus used is that it should produce rapid deformation rather than a true impact.

Because of the poor reproducibility of this test method, the method should be restricted to testing in only one laboratory when the results are expressed as numerical values. Interlaboratory agreement is improved when ranking is used in place of numerical values.

### 2 Normative references

[ISO 6272-2:2011](https://standards.iteh.ai/catalog/standards/sist/73b5a42a-814b-4297-bcd0-9147a3057db2/iso-6272-2-2011)

<https://standards.iteh.ai/catalog/standards/sist/73b5a42a-814b-4297-bcd0-9147a3057db2/iso-6272-2-2011>

The following referenced documents are indispensable for the application of this document. For dated references, only the edition cited applies. For undated references, the latest edition of the referenced document (including any amendments) applies.

ISO 1513, *Paints and varnishes — Examination and preparation of test samples*

ISO 1514, *Paints and varnishes — Standard panels for testing*

ISO 2808, *Paints and varnishes — Determination of film thickness*

ISO 3270, *Paints and varnishes and their raw materials — Temperatures and humidities for conditioning and testing*

ISO 13076, *Paints and varnishes — Lighting and procedure for visual assessments*

ISO 15528, *Paints, varnishes and raw materials for paints and varnishes — Sampling*

### 3 Principle

The coating under test is applied to suitable thin metal panels. After the coatings have cured, a standard weight is dropped a distance so as to strike an indenter that deforms the coating and the substrate. The test can be carried out with the coated side of the panel facing upwards (i.e. towards the falling weight and indenter) or downwards (i.e. away from the weight and indenter). By gradually increasing the distance the weight drops, the point at which failure occurs can be determined. Films generally fail by cracking, which is made more visible by the use of a magnifier or, on steel, by the application of a copper sulfate solution.

## 4 Apparatus

**4.1 Falling-weight apparatus** (see Figure 1), consisting basically of a vertical tube to guide a cylindrical weight that is dropped on an indenter resting on the test panel and including the components described in 4.1.1 to 4.1.4.

**4.1.1 Guide tube**, 0,6 m to 1,2 m long, mounted vertically on a baseplate. A slot is cut lengthwise on one side of the tube to act as a guide for a cylindrical weight that fits inside the tube. Graduations are marked in millimetres along the slot. The base is constructed so that a thin flat panel can be inserted 50 mm below the tube.

**4.1.2 Weight**, consisting of a metal cylinder made to fit inside the guide tube. A pin is fitted into one side of the weight to act as a guide by riding in the slot in the tube, to serve as a handle by which the weight can be raised and released and to indicate the height in millimetres. The mass of the weight is either  $(1\ 000 \pm 10)$  g or  $(2\ 000 \pm 20)$  g.

To avoid excessive friction and to ensure accurate guidance, the difference between the inner diameter of the guide tube and the outer diameter of the falling weight shall be  $(1 \pm 0,2)$  mm.

**4.1.3 Indenter**, made of hardened steel (55 HRC to 60 HRC), with a mass of  $(150 \pm 15)$  g and with a hemispherical head having a diameter of either  $(12,7 \pm 0,06)$  mm or  $(15,9 \pm 0,06)$  mm. The head rests on the test panel and the indenter is held vertically by a guide ring.

To avoid excessive friction and to ensure accurate guidance, the difference between the inner diameter of the guide ring and the outer diameter of the indenter shall be  $(0,1 \pm 0,05)$  mm.

**4.1.4 Panel support**, consisting of a steel fixture with a cylindrical hole of diameter  $(16,3 \pm 0,1)$  mm centred under the indenter to support the test panel.

**4.2 Viewing lens**, with a magnification of  $\times 10$ . [ISO 6272-2:2011  
https://standards.iteh.ai/catalog/standards/sist/73b5a42a-814b-4297-bcd0-9147a3057db2/iso-6272-2-2011](https://standards.iteh.ai/catalog/standards/sist/73b5a42a-814b-4297-bcd0-9147a3057db2/iso-6272-2-2011)

## 5 Reagents

**5.1 Acidified copper sulfate ( $\text{CuSO}_4$ ) solution**, prepared by dissolving 10 g of  $\text{CuSO}_4 \cdot 5 \text{H}_2\text{O}$  in 90 g of hydrochloric acid,  $c(\text{HCl}) = 1,0$  mol/l.

## 6 Sampling

Take a representative sample of the coating material to be tested (or of each product in the case of a multi-coat system), as described in ISO 15528.

Examine and prepare each sample for testing, as described in ISO 1513.

## 7 Test panels

### 7.1 Substrate

The substrate shall be metal, conforming to the requirements of ISO 1514.

The panels shall be planar, free from distortion and at least 0,25 mm thick. The dimensions shall be such as to allow the test to be carried out at at least five different positions not less than 40 mm from each other and not less than 20 mm from the edge of the panel.

Measure the thickness to the nearest 0,01 mm.

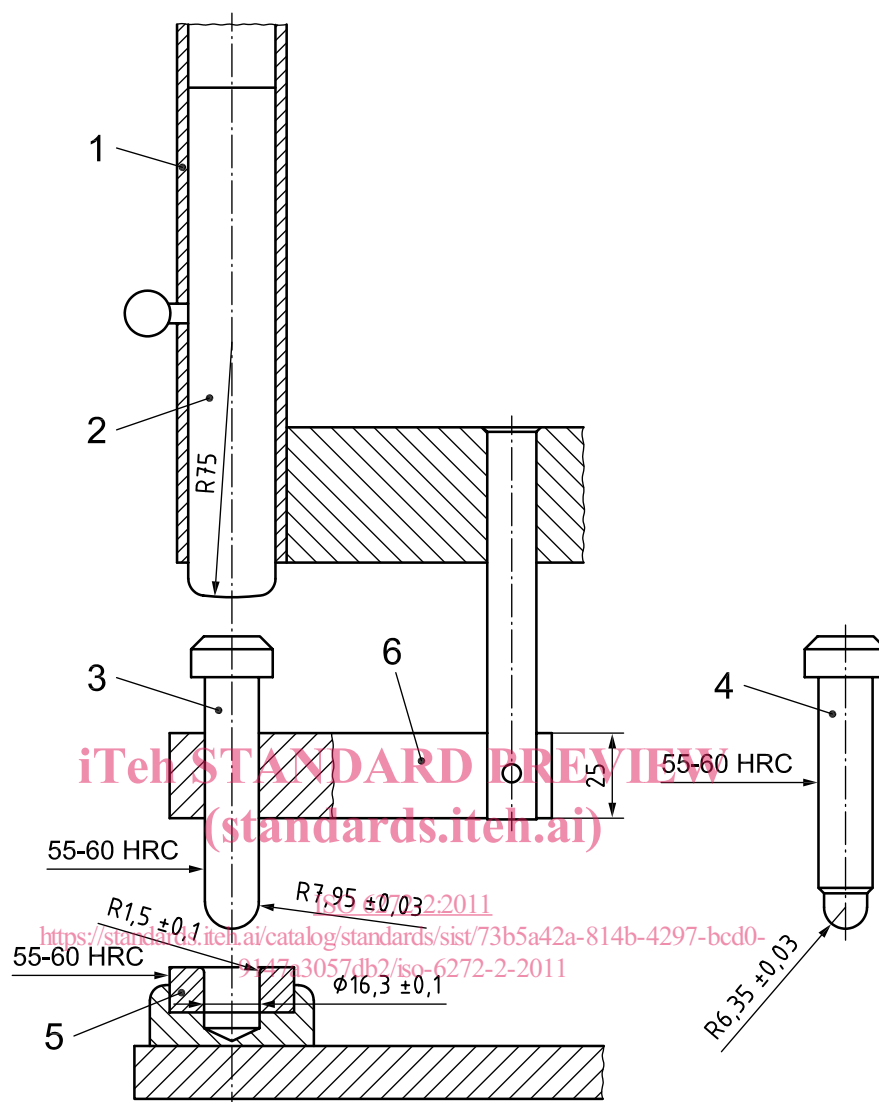
**Key**

- 1 guide tube
- 2 weight
- 3 indenter, nose diameter 15,9 mm
- 4 indenter, nose diameter 12,7 mm
- 5 panel support
- 6 guide ring

**Figure 1 — Falling-weight apparatus showing required dimensions**

## 7.2 Preparation and coating

Prepare each test panel (7.1) in accordance with ISO 1514 and then coat it by the method specified by the manufacturer of the product or system under test to give the dry-film thickness specified by the manufacturer, or coat it by a method agreed upon between the interested parties to give a dry-film thickness agreed upon between the interested parties.

The coating method and dry-film thickness used shall be included in the test report [see Clause 10, items c) 2) and c) 4)].

### 7.3 Drying

Dry (or stove) and age (if applicable) each coated test panel for the time, and under the conditions, specified by the manufacturer of the product or system under test, or as agreed between the interested parties.

The time and conditions used shall be included in the test report [see Clause 10, item c) 3)].

### 7.4 Thickness of coating

Determine the thickness, in micrometres, of the dried coating by one of the procedures specified in ISO 2808. Make the measurements at, or as near as possible to, the positions at which the test is to be carried out.

Use only test panels for which the film thickness values do not differ from the specified or agreed film thickness by more than 10 %.

## 8 Procedure

### 8.1 General

Before testing, condition the coated panels at a temperature of  $(23 \pm 2)^\circ\text{C}$  and a relative humidity of  $(50 \pm 5)\%$  (or at another temperature and humidity, agreed between the interested parties, from those specified in ISO 3270) for a minimum period of 16 h. Begin the test procedure as soon as possible after conditioning, but in any case complete it not later than 30 min after removal of the test panels from conditioning.

Mount the apparatus on a firm surface (for example, concrete, steel or stone).

Carry out the test at  $(23 \pm 2)^\circ\text{C}$  or at another temperature, agreed between the interested parties, from those specified in ISO 3270. State the test temperature at which the test was carried out in the test report.

Measure the relative humidity during the test and state it in the test report.

### 8.2 Classification test (to determine the minimum drop height which will cause cracking or peeling)

Install the indenter having the head diameter specified or agreed upon. Place a test panel in the apparatus with the coated face up or down, as specified or agreed upon. Be sure the panel is flat against the panel support and that the indenter is in contact with the top surface of the panel. Lightly place the weight on the indenter and adjust the guide tube so that the lifting pin is at the zero mark. Raise the weight up the tube to a height where it is expected that no failure will occur. Release the weight so that it drops on the indenter.

Remove the test panel from the apparatus and observe the impact area for cracks in the coating. If no cracks are evident, repeat the procedure at a greater height, increasing 25 mm at a time. Once visible cracks and/or peeling are observed, continue as follows. Release the appropriate weight and allow it to fall on to the test panel five times at different positions from each of the following heights:

- the height where cracks and/or peeling were first observed;
- 25 mm below this height.

Test in a random fashion, taking care that not all impacts from one height are made in succession on one panel.



Examine, using the lighting and the procedure specified in ISO 13076, the impacted areas for cracking and/or peeling by one of the following methods:

- a) Use a viewing lens.
- b) Hold a white flannel-type cloth saturated with acidified copper sulfate solution (5.1) on the impacted areas for at least 15 min. Remove the cloth and examine both the test areas and the cloth for evidence of copper deposition or iron-rust staining, respectively.

NOTE The copper sulfate solution will not perform properly on zinc-phosphate-treated metal unless the conversion coating cracks.

For each height, tabulate the number of times the coating passed or failed. The height at which the results change from mainly passing to mainly failing is the impact failure end point of the test.

If no end point can be established, repeat the procedure, taking all heights 25 mm higher or lower, as appropriate, to ensure that the end point of the test is covered by the range of heights tested.

## 9 Precision

No precision data are currently available.

## 10 Test report

The test report shall contain at least the following information:

- a) all details necessary to identify the product tested;
- b) a reference to this part of ISO 6272 (ISO 6272-2:2011);
- c) details of the panels and their preparation, including the following:
  - 1) the material, thickness and surface preparation of the substrate (see 7.1),
  - 2) the method of application of the test coating to the substrate, including the duration and conditions of drying between coats in the case of a multi-coat system (see 7.2),
  - 3) the duration and conditions of drying (or stoving) the coat and ageing (if applicable) of the coat before testing (see 7.3),
  - 4) the thickness, in micrometres, of the dry coating and the method of measurement used from ISO 2808 (see 7.4), and whether it is a single coating or a multi-coat system;
- d) the temperature and relative humidity during the test;
- e) whether the indenter struck the coated face of the test panel or the uncoated face, or both;
- f) the diameter of the indenter used;
- g) the result of the test as indicated in Clause 8, indicating the drop height, in millimetres, at the impact failure end point [because of the poor reproducibility of this method, reporting of the drop height in millimetres when comparing coatings for impact resistance should be restricted to one laboratory (see Clause 1)];
- h) any deviation from the test method specified;
- i) any unusual features (anomalies) observed during the test;
- j) the date of the test.