Reference

REN/EE-0264

Keywords

environment, interface, power supply

ETSI

650 Route des Lucioles
F-06921 Sophia Antipolis Cedex - FRANCE

Tel.: +33 4 92 94 42 00 Fax: +33 4 93 65 47 16

Siret N° 348 623 562 00017 - NAF 742 C
Association à but non lucratif enregistrée à la
Sous-Préfecture de Grasse (06) N° 7803/88

Important notice

The present document can be downloaded from:

<http://www.etsi.org/standards-search>

The present document may be made available in electronic versions and/or in print. The content of any electronic and/or print versions of the present document shall not be modified without the prior written authorization of ETSI. In case of any existing or perceived difference in contents between such versions and/or in print, the prevailing version of an ETSI deliverable is the one made publicly available in PDF format at www.etsi.org/deliver.

Users of the present document should be aware that the document may be subject to revision or change of status.

Information on the current status of this and other ETSI documents is available at

<https://portal.etsi.org/TB/ETSIDeliverableStatus.aspx>

If you find errors in the present document, please send your comment to one of the following services:

<https://portal.etsi.org/People/CommiteeSupportStaff.aspx>

Copyright Notification

No part may be reproduced or utilized in any form or by any means, electronic or mechanical, including photocopying and microfilm except as authorized by written permission of ETSI.

The content of the PDF version shall not be modified without the written authorization of ETSI.

The copyright and the foregoing restriction extend to reproduction in all media.

© ETSI 2019.

All rights reserved.

DECT™, **PLUGTESTS™**, **UMTS™** and the ETSI logo are trademarks of ETSI registered for the benefit of its Members.

3GPP™ and **LTE™** are trademarks of ETSI registered for the benefit of its Members and of the 3GPP Organizational Partners.

oneM2M™ logo is a trademark of ETSI registered for the benefit of its Members and of the oneM2M Partners.

GSM® and the GSM logo are trademarks registered and owned by the GSM Association.

Contents

Intellectual Property Rights	5
Foreword.....	5
Modal verbs terminology.....	5
1 Scope	6
2 References	6
2.1 Normative references	6
2.2 Informative references.....	7
3 Definition of terms, symbols and abbreviations.....	7
3.1 Terms.....	7
3.2 Symbols.....	8
3.3 Abbreviations	8
4 Power Interface A1.....	9
5 AC interface requirements A1.....	10
5.0 Introduction	10
5.1 Nominal voltage at interface A1.....	11
5.2 Normal service voltage range categories at interface A1.....	11
5.3 Reference test voltage (U_T) at interface A1.....	12
5.4 Abnormal service voltage ranges at interface A1.....	12
6 Voltage variations, voltage dips, short interruptions and voltage surges at interface A1	13
6.0 Introduction	13
6.1 Voltage variations.....	13
6.2 Voltages dips	14
6.3 Short interruptions	15
6.4 Voltage surges	15
7 AC Supply protection on interface A1	16
8 Maximum steady state current I_m in the normal service voltage range at interface A1	17
9 Inrush current on interface A1.....	17
9.1 Limits	17
9.2 Measurement method	18
9.3 Protective device ratings	19
10 Earthing and Bonding.....	19
11 Electrical Safety requirements.....	19
12 EMC requirements at the input of ICT equipment.....	19
Annex A (informative): ICT power supply configurations providing a unified power interface in the present document	20
Annex B (normative): Identification of interface A1	22
Annex C (informative): Calculation of the extreme AC voltage range at interface A1	23
Annex D (informative): Dimensioning of over-current protective devices.....	24
Annex E (normative): Test generator for voltage dips, short interruptions and voltage variations	25
Annex F (informative): Details of the voltage surges measurement in the most common case of distribution and protective devices	26

Annex G (informative):	Guide for measuring inrush current and for transferring the recorded pulses onto the limit chart.....	27
G.1	Measurement.....	27
G.2	Pulse waveform transformation.....	27
History	29

iTeh STANDARD PREVIEW
(standards.iteh.ai)

Full standard:
<https://standards.iteh.ai/catalog/standards/sist/997a0fbb-3fce-4385-9626-e080723eca86/etsi-en-300-132-1-v2.1.1-2019-03>

Intellectual Property Rights

Essential patents

IPRs essential or potentially essential to normative deliverables may have been declared to ETSI. The information pertaining to these essential IPRs, if any, is publicly available for **ETSI members and non-members**, and can be found in ETSI SR 000 314: "*Intellectual Property Rights (IPRs); Essential, or potentially Essential, IPRs notified to ETSI in respect of ETSI standards*", which is available from the ETSI Secretariat. Latest updates are available on the ETSI Web server (<https://ipr.etsi.org/>).

Pursuant to the ETSI IPR Policy, no investigation, including IPR searches, has been carried out by ETSI. No guarantee can be given as to the existence of other IPRs not referenced in ETSI SR 000 314 (or the updates on the ETSI Web server) which are, or may be, or may become, essential to the present document.

Trademarks

The present document may include trademarks and/or tradenames which are asserted and/or registered by their owners. ETSI claims no ownership of these except for any which are indicated as being the property of ETSI, and conveys no right to use or reproduce any trademark and/or tradename. Mention of those trademarks in the present document does not constitute an endorsement by ETSI of products, services or organizations associated with those trademarks.

Foreword

This European Standard (EN) has been produced by ETSI Technical Committee Environmental Engineering (EE).

The present document is part 1 of a multi-part deliverable covering Environmental Engineering (EE); Power supply interface at the input to Information and Communication Technology (ICT) equipment, as identified below:

- Part 1: "Alternating Current (AC)";
- Part 2: "-48 V Direct Current (DC)";
- Part 3: "Up to 400 V Direct Current (DC)";

National transposition dates

Date of adoption of this EN:	8 March 2019
Date of latest announcement of this EN (doa):	30 June 2019
Date of latest publication of new National Standard or endorsement of this EN (dop/e):	31 December 2019
Date of withdrawal of any conflicting National Standard (dow):	31 December 2019

Modal verbs terminology

In the present document "**shall**", "**shall not**", "**should**", "**should not**", "**may**", "**need not**", "**will**", "**will not**", "**can**" and "**cannot**" are to be interpreted as described in clause 3.2 of the [ETSI Drafting Rules](#) (Verbal forms for the expression of provisions).

"**must**" and "**must not**" are **NOT** allowed in ETSI deliverables except when used in direct citation.

1 Scope

The present document contains requirements for:

- the output of the power supply feeding interface A1;
- the input of the ICT equipment connected to interface A1.

The voltage at interface A1 defined in the present document is single phase and three phase AC.

The following voltage range categories are covered:

- Narrow single phase $A1_{n-1p}$ and narrow three phase $A1_{n-3p}$ AC voltage range defined to comply with nominal European AC voltages [i.2].
- Wide single phase $A1_{w-1p}$ and wide three phase $A1_{w-3p}$ AC voltage range for worldwide nominal AC voltages.

The present document aims at providing compatibility between the power supply equipment and both the ICT equipment, and the different load units connected to the same interface A1 (e.g. control/monitoring, cooling system, etc.).

The purpose of the present document is:

- to identify a power supply system with the same characteristics for all ICT equipment defined in the area of application; the area of application may be any location where the interface A1 is used i.e. telecommunication centres, Radio Base Stations, datacentres and customer premises;
- to facilitate interworking of different (types of) loads;
- to facilitate the standardization of power supply systems for ICT equipment;
- to facilitate the installation, operation and maintenance in the same network of ICT equipment and systems from different origins. General requirements for safety and EMC are out of the scope of the present document series unless specific requirement not defined in existing safety or EMC standards.

The present document concerns the requirements for the interface between Information and Communication Technology (ICT) equipment and its power supply. It includes requirements relating to its stability and measurement. Various other references and detailed measurement and test arrangements are contained in informative annexes.

2 References

2.1 Normative references

References are either specific (identified by date of publication and/or edition number or version number) or non-specific. For specific references, only the cited version applies. For non-specific references, the latest version of the referenced document (including any amendments) applies.

Referenced documents which are not found to be publicly available in the expected location might be found at <https://docbox.etsi.org/Reference/>.

NOTE: While any hyperlinks included in this clause were valid at the time of publication, ETSI cannot guarantee their long term validity.

The following referenced documents are necessary for the application of the present document.

- [1] IEC 60947-2: "Low-voltage switchgear and controlgear - Part 2: Circuit-breakers".
- [2] IEC 60269-1: "Low-voltage fuses - Part 1: General requirements".
- [3] IEC 61000-4-5: "Electromagnetic compatibility (EMC) - Part 4-5: Testing and measurement techniques - Surge immunity test".

- [4] IEC 61000-4-11: "Electromagnetic compatibility (EMC) - Part 4-11: Testing and measurement techniques - Voltage dips, short interruptions and voltage variations immunity tests".

2.2 Informative references

References are either specific (identified by date of publication and/or edition number or version number) or non-specific. For specific references, only the cited version applies. For non-specific references, the latest version of the referenced document (including any amendments) applies.

NOTE: While any hyperlinks included in this clause were valid at the time of publication, ETSI cannot guarantee their long term validity.

The following referenced documents are not necessary for the application of the present document but they assist the user with regard to a particular subject area.

- [i.1] ETSI ETS 300 132-1 (Edition 1): "Equipment Engineering (EE); Power supply interface at the input to telecommunications equipment; Part 1: Operated by alternating current (ac) derived from direct current (dc) sources".
- [i.2] IEC 60038: "IEC standard voltages".
- [i.3] IEC 60050-601: "International Electrotechnical Vocabulary. Chapter 601: Generation, transmission and distribution of electricity - General".
- [i.4] Void.
- [i.5] ETSI EN 300 386: "Telecommunication network equipment; ElectroMagnetic Compatibility (EMC) requirements; Harmonised Standard covering the essential requirements of the Directive 2014/30/EU".
- [i.6] Void.
- [i.7] CENELEC EN 62368-1 (Ed. 1.0): "Audio, Video, Information and Communication Technology Equipment - Part 1: Safety requirements".
- [i.8] IEC 60445: "Basic and safety principle for man-machine interface, marking and identification - Identification of equipment terminals, conductor terminations, and conductors".
- [i.9] IEC 60898-1:2015: "Electrical accessories - Circuit-breakers for overcurrent protection for household and similar installations - Part 1: Circuit-breakers for a.c. operation".
- [i.10] IEC 60898-2: "Electrical accessories - Circuit-breakers for overcurrent protection for household and similar installations - Part 2: Circuit-breakers for AC and DC operation".
- [i.11] IEC 60364 series: "Low-voltage electrical installations".
- [i.12] IEC 62040 series: "Uninterruptible power systems (UPS)".

3 Definition of terms, symbols and abbreviations

3.1 Terms

For the purposes of the present document, the following terms apply:

abnormal service voltage ranges: steady-state voltage ranges over which the ICT equipment will not be expected to maintain normal service but will survive undamaged

area of application: any location where the interface A1 is used i.e. telecommunication centres, Radio Base Stations, datacentres and customer premises

customer premises: location which is the sole responsibility of the customer

ICT equipment: device, in the telecommunication network infrastructure, that provides an ICT service

interface A: interface, physical point, at which -48 VDC power supply is connected in order to operate the ICT equipment

interface A1: interface, physical point, at which AC power supply is connected in order to operate the ICT equipment

NOTE: $A1_n$ and $A1_w$ are used for different voltage ranges: narrow and wide respectively.

interface A3: interface, physical point, at which 400 VDC power supply is connected in order to operate the ICT equipment

load unit: power consuming equipment, that is part of a system block

nominal voltage: value of the voltage by which the electrical installation or part of the electrical installation is designated and identified

NOTE: This definition is based on nominal voltage defined in IEC 60050-601 [i.3].

normal service: service mode where ICT equipment operates within its specification

normal service voltage range: range of the steady-state voltage at the A1 interface over which the equipment will maintain normal service

power supply: power supply to which ICT equipment is intended to be connected

reference test voltage: voltage used as a reference to define the test voltage in the present document

NOTE: The test voltage may be also a percentage of this voltage.

system block: functional group of ICT equipment depending for its operation and performance on its connection to the same power supply

telecommunication centre: any location where ICT equipment is installed and is the sole responsibility of the operator

3.2 Symbols

For the purposes of the present document, the following symbols apply:

I_m	maximum steady state current drain at interface A1
I_t	instantaneous surge current at interface A1
I_{UT}	maximum steady state current drain at U_T at interface A1

3.3 Abbreviations

For the purposes of the present document, the following abbreviations apply:

AC Alternating Current

NOTE: Also when used as a suffix to units of measurement.

DC Direct Current

NOTE: Also when used as a suffix to units of measurement.

EMC ElectroMagnetic Compatibility

EUT Equipment Under Test

ICT Information and Communication Technology

L Phase conductor

LISN Line Impedance Stabilization Networks

N Neutral conductor

PE Protective Earth

RMS	Root Mean Square
U_T	Reference Test Voltage
UPS	Uninterruptible Power Supply
VAC	Volts Alternating Current
VDC	Volts Direct Current

4 Power Interface A1

The power supply interface, interface A1 of figure 1, is a physical point to which all the requirements are related. This point is situated between the power supply system(s) and the power consuming ICT equipment of the area of application defined in the scope of the present document.

An example of configurations in which interface A1 is identified is given in annex B.

Interface A1 is located at the power terminals of the ICT equipment or system as defined by the manufacturer in accordance to IEC 60445 [i.8].

NOTE 1: Subject to the installation preconditions, this point may be located at any other point between the power supply system and the ICT equipment by mutual agreement of the relevant parties.

NOTE 2: The power supply can be derived from AC grid e.g. through AC bypass of UPS or inverters.

iTeh STANDARD PREVIEW
(standards.iteh.ai)
Full standard:
<https://standards.iteh.ai/catalog/standards/sist/997a0fbb-3fcd-4385-9626-e080723eca86/etsi-en-300-132-1-v2.1.1-2019-03>

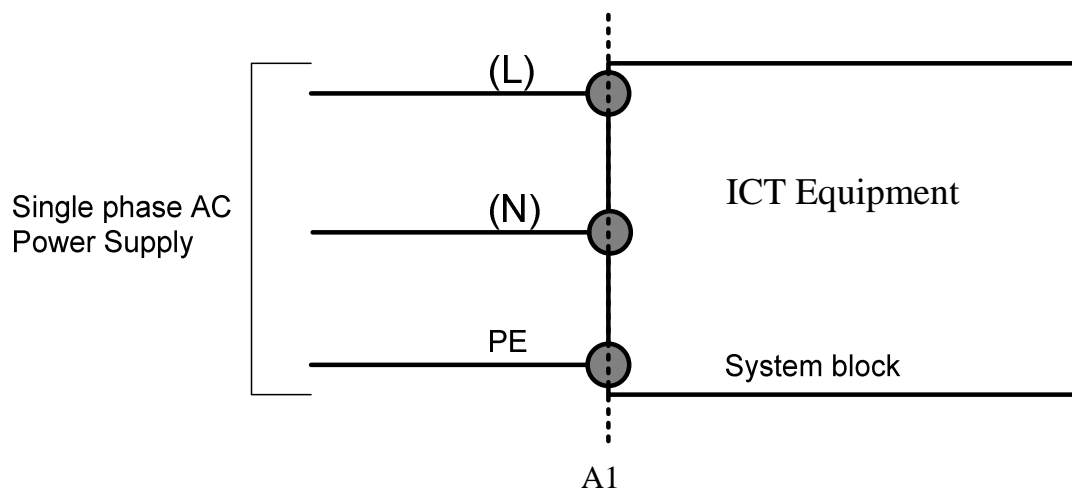

- (L) Live AC terminal in single phase supply.
 (N) Neutral AC terminal.
 PE Protective Earth.

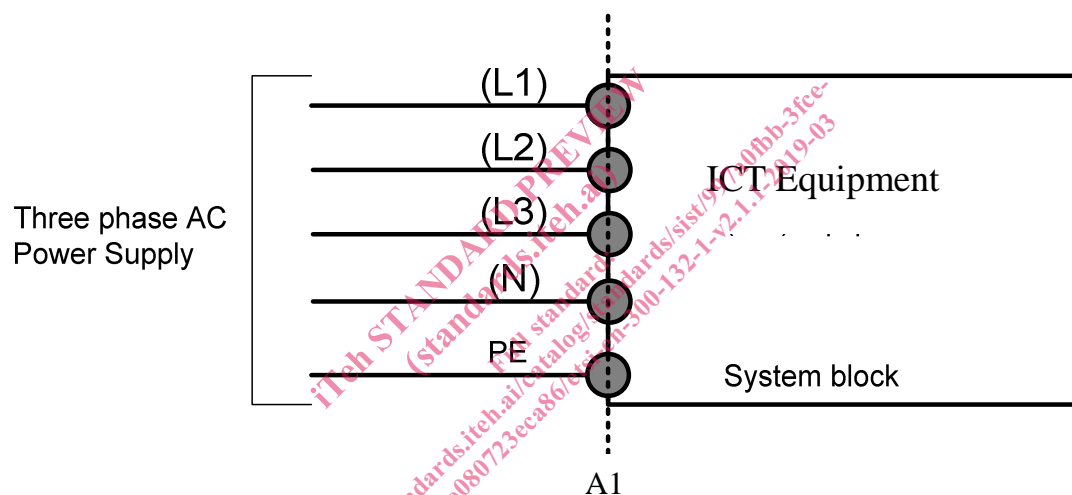

- (L1, L2, L3) Live AC terminals in 3 phases supply.
 (N) Optional Neutral AC terminal.
 PE Protective Earth.

Figure 1: General identification of the interface A1 in single and 3 phase AC supply

5 AC interface requirements A1

5.0 Introduction

The definition of the AC interface voltages ranges and typical operating voltage values are defined in the following subclauses of clause 5.