



Designation: D 5801 – 95 (Reapproved 2006)

Standard Test Method for Toughness and Tenacity of Bituminous Materials¹

This standard is issued under the fixed designation D 5801; the number immediately following the designation indicates the year of original adoption or, in the case of revision, the year of last revision. A number in parentheses indicates the year of last approval. A superscript epsilon (ϵ) indicates an editorial change since the last revision or reapproval.

1. Scope

1.1 This test method describes the procedure for measuring the toughness and tenacity of bituminous materials. Typically, the test method has been used to characterize elastomer modified asphalts, although values for toughness and tenacity may be obtained for any type of polymer-modified or non-modified asphalt.

1.2 *This standard does not purport to address all of the safety concerns, if any, associated with its use. It is the responsibility of the user of this standard to establish appropriate safety and health practices and determine the applicability of regulatory limitations prior to use.*

1.3 The values given in SI units are to be regarded as the standard. The values given in inch-pound units in parentheses are for informational purposes only.

1.4 *This standard does not purport to address all of the safety concerns, if any, associated with its use. It is the responsibility of the user of this standard to establish appropriate safety and health practices and determine the applicability of regulatory limitations prior to use.*

2. Referenced Documents

2.1 *ASTM Standards:*²

D 5 Test Method for Penetration of Bituminous Materials

E 1 Specification for ASTM Liquid-in-Glass Thermometers

3. Summary of Test Method

3.1 A tension head of specified size and shape is pulled from an asphalt sample at a rate of 50 cm/min (20 in./min). A continuous record of the force versus elongation curve is made and used to calculate the toughness and the tenacity of the sample. The test is run at room temperature ($25 \pm 3^\circ\text{C}$ [$77 \pm 5^\circ\text{F}$]), after the sample has been subjected to a specified temperature history.

¹ This test method is under the jurisdiction of ASTM Committee D04 on Road and Paving Materials and is the direct responsibility of Subcommittee D04.44 on Rheological Tests.

Current edition approved Dec. 1, 2006. Published December 2006. Originally approved as Proposal P 243 in 1994. Last previous edition approved in 2001 as D 5801 – 95 (2001).

² For referenced ASTM standards, visit the ASTM website, www.astm.org, or contact ASTM Customer Service at service@astm.org. For *Annual Book of ASTM Standards* volume information, refer to the standard's Document Summary page on the ASTM website.

3.2 Toughness is defined in this procedure as the total work required to completely separate the tension head from the sample under the specified test conditions. Tenacity is a measure of the increasing force as the sample is stretched past the initial peak, and may indicate the type and amount of polymer used to modify the asphalt. It is defined as the work required to stretch the material after the initial resistance is overcome.

4. Significance and Use

4.1 This test method is useful in confirming that an asphalt cement has been modified with a material that provides a significant elastomeric component. Elastomer modified asphalts can be characterized by their ability to be stretched to a large elongation while at the same time resisting further stretching. Toughness and tenacity are two parameters for measuring this ability.

5. Apparatus

5.1 *Sample Container*—A metal, cylindrical, flat bottom container with a nominal inside diameter of 55 mm ($2\frac{1}{8}$ in.) and a depth of 35 mm ($1\frac{3}{8}$ in.) shall be used to hold the sample. Containers known as tin boxes or seamless ointment boxes with a 3-oz capacity meet these requirements.

5.2 *Tension Head*—The tension head shall consist of a polished metal, hemispherical head with an 11 mm ($\frac{7}{16}$ in.) radius, which is integrally connected to a 6.4 mm ($\frac{1}{4}$ in.) diameter stem approximately 33 mm ($1\frac{5}{16}$ in.) long. The stem shall be threaded and fitted with a knurled lowering screw to allow for accurate adjustment of the tension head height in the sample container. The stem of the tension head shall be fitted with a small pin to prevent twisting of the head while adjusting the height. Dimensions of the tension head are shown in **Fig. 1**.

NOTE 1—Brass and stainless steel are acceptable metals for constructing tension heads. Aluminum scratches easily and steel rusts, so these metals should not be used.

5.3 *Spider*—The support for the tension head shall consist of a cylindrical center section through which the stem of the tension head may freely move parallel to the axis of the cylinder. The inner wall of the cylinder shall be grooved to receive the pin mounted on the stem of the tension head. The spider cylinder shall be fitted with three arms, equally spaced at 120 degrees, extending from the center and notched to

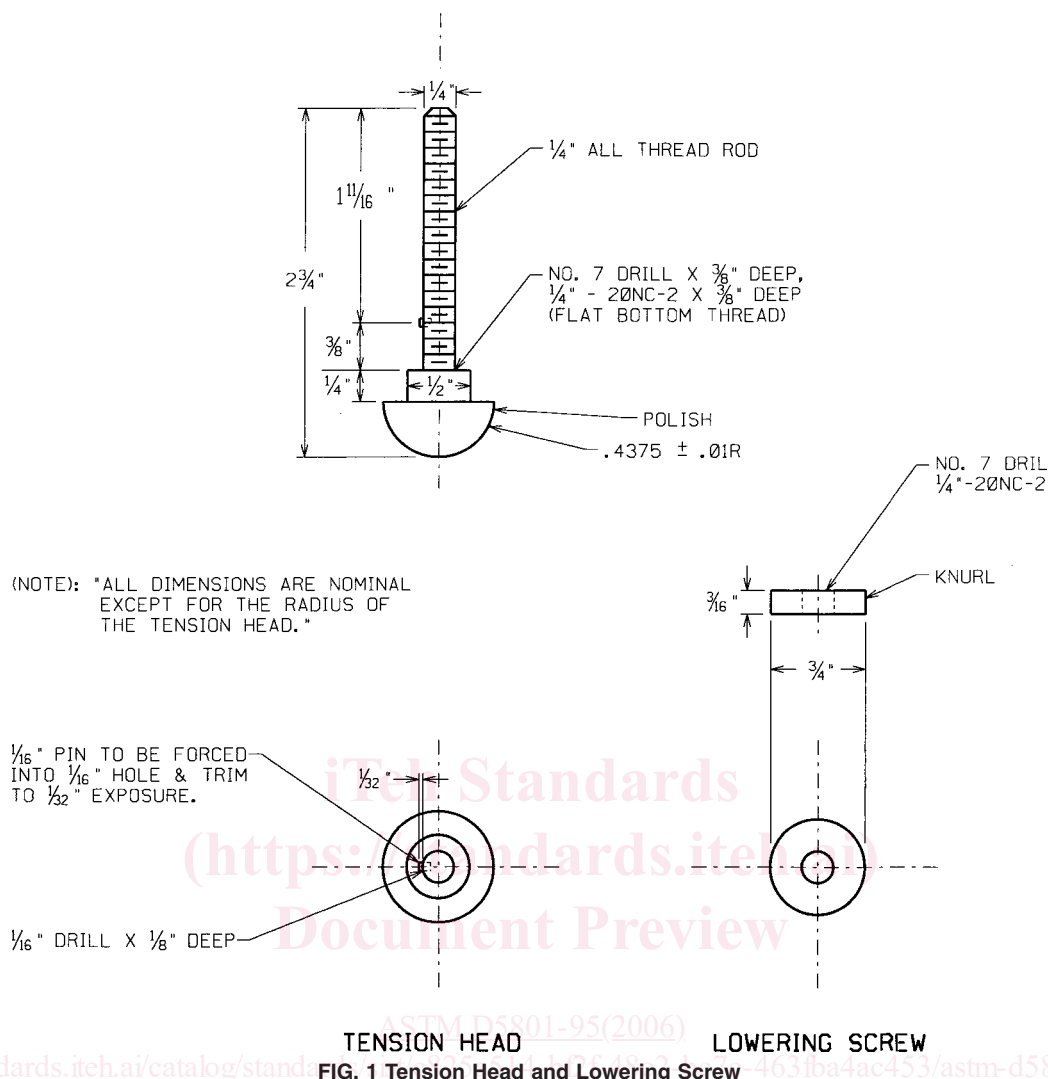

FIG. 1 Tension Head and Lowering Screw

receive the lip of the sample container, thereby centering the spider and tension head in the sample container. Details of the spider construction are shown in Fig. 2.

5.4 *Testing Machine*—Any tensile tester capable of pulling the tension head at a uniform rate of 50 cm/min (20 in./min), and recording the force versus elongation curve, may be used. The accuracy of the pull rate shall be $\pm 2\%$ or better. The maximum load capacity shall be at least 45 kg (100 lb). If polymer modified asphalts are to be tested after aging in the thin film oven or the rolling thin film oven, higher load capacities are needed. A maximum load capacity of 90 kg (200 lb) is suggested.

5.4.1 The tensile tester must be equipped to hold the sample container firmly in place while the tension head is pulled away. The details of this sample holder will vary with the type of tester used. The tester must have a minimum effective pull length of 61 cm (24 in.) after installing the sample holder.

5.5 *Water Bath*—A bath capable of maintaining a temperature of $25 \pm 0.1^\circ\text{C}$ ($77 \pm 0.18^\circ\text{F}$) is required. The bath shall have a perforated shelf supported in a position not less than 50 mm (2 in.) from the bottom and not less than 100 mm (4 in.) below the liquid level.

5.6 *Oven*—A gravity convection oven capable of maintaining a temperature of $163 \pm 5.5^\circ\text{C}$ ($325 \pm 10^\circ\text{F}$) shall be used to heat the samples.

5.7 *Thermometer*—A calibrated thermometer having a range as shown as follows and conforming to the requirements prescribed in Specification E 1.

Temperature Range	ASTM Thermometer Number
-8 to 32°C	63C
18 to 89°F	63F

NOTE 2—In those cases where the samples are conditioned in the standard penetration bath, the thermometer as prescribed for Test Method D 5 may be substituted in place of the above.

6. Sample Preparation

6.1 Bring the sample to a temperature where it is sufficiently fluid to pour, as described in the following paragraphs.

6.1.1 If the sample is at room temperature, place the sample in a loosely covered container in an oven at 163°C (325°F) until the sample is at a uniform temperature and sufficiently fluid to pour. Take care to prevent local overheating of the sample.