**Metallic powders — Determination of flow
rate by means of a calibrated funnel
(Hall flowmeter)**

*Poudres métalliques — Détermination du temps d'écoulement au
moyen d'un entonnoir calibré (appareil de Hall)*

iTeh STANDARD PREVIEW
(standards.iteh.ai)

[ISO 4490:2008](https://standards.iteh.ai/catalog/standards/sist/eb5c5721-048b-4e8f-900b-851fc86d108d/iso-4490-2008)

[https://standards.iteh.ai/catalog/standards/sist/eb5c5721-048b-4e8f-900b-
851fc86d108d/iso-4490-2008](https://standards.iteh.ai/catalog/standards/sist/eb5c5721-048b-4e8f-900b-851fc86d108d/iso-4490-2008)



PDF disclaimer

This PDF file may contain embedded typefaces. In accordance with Adobe's licensing policy, this file may be printed or viewed but shall not be edited unless the typefaces which are embedded are licensed to and installed on the computer performing the editing. In downloading this file, parties accept therein the responsibility of not infringing Adobe's licensing policy. The ISO Central Secretariat accepts no liability in this area.

Adobe is a trademark of Adobe Systems Incorporated.

Details of the software products used to create this PDF file can be found in the General Info relative to the file; the PDF-creation parameters were optimized for printing. Every care has been taken to ensure that the file is suitable for use by ISO member bodies. In the unlikely event that a problem relating to it is found, please inform the Central Secretariat at the address given below.

iTeh STANDARD PREVIEW
(standards.iteh.ai)

ISO 4490:2008

<https://standards.iteh.ai/catalog/standards/sist/eb5c5721-048b-4e8f-900b-851fc86d108d/iso-4490-2008>



COPYRIGHT PROTECTED DOCUMENT

© ISO 2008

All rights reserved. Unless otherwise specified, no part of this publication may be reproduced or utilized in any form or by any means, electronic or mechanical, including photocopying and microfilm, without permission in writing from either ISO at the address below or ISO's member body in the country of the requester.

ISO copyright office
Case postale 56 • CH-1211 Geneva 20
Tel. + 41 22 749 01 11
Fax + 41 22 749 09 47
E-mail copyright@iso.org
Web www.iso.org

Published in Switzerland

Foreword

ISO (the International Organization for Standardization) is a worldwide federation of national standards bodies (ISO member bodies). The work of preparing International Standards is normally carried out through ISO technical committees. Each member body interested in a subject for which a technical committee has been established has the right to be represented on that committee. International organizations, governmental and non-governmental, in liaison with ISO, also take part in the work. ISO collaborates closely with the International Electrotechnical Commission (IEC) on all matters of electrotechnical standardization.

International Standards are drafted in accordance with the rules given in the ISO/IEC Directives, Part 2.

The main task of technical committees is to prepare International Standards. Draft International Standards adopted by the technical committees are circulated to the member bodies for voting. Publication as an International Standard requires approval by at least 75 % of the member bodies casting a vote.

Attention is drawn to the possibility that some of the elements of this document may be the subject of patent rights. ISO shall not be held responsible for identifying any or all such patent rights.

ISO 4490 was prepared by Technical Committee ISO/TC 119, *Powder metallurgy*, Subcommittee SC 2, *Sampling and testing methods for powders (including powders for hardmetals)*.

This third edition cancels and replaces the second edition (ISO 4490:2001), which has been technically revised.

iTeh STANDARD PREVIEW
(standards.iteh.ai)
<https://standards.iteh.ai/catalog/standards/sist/eb5c5721-048b-4e8f-900b-851fc86d108d/iso-4490-2008>

iTeh STANDARD PREVIEW
(standards.iteh.ai)

ISO 4490:2008

<https://standards.iteh.ai/catalog/standards/sist/eb5c5721-048b-4e8f-900b-851fc86d108d/iso-4490-2008>

Metallic powders — Determination of flow rate by means of a calibrated funnel (Hall flowmeter)

1 Scope

This International Standard specifies a method for determining the flow rate of metallic powders, including powders for hardmetals, by means of a calibrated funnel (Hall flowmeter).

The method is applicable only to powders which flow freely through the specified test orifice.

2 Principle

Measurement of the time required for 50 g of a metallic powder to flow through the orifice of a calibrated funnel of standardized dimensions.

iTeh STANDARD PREVIEW
(standards.iteh.ai)

3 Apparatus

3.1 Calibrated funnel, having the dimensions shown in Figure 1 (see Clause 4).

ISO 4490:2008

The funnel shall be made of a non-magnetic, corrosion-resistant metallic material having sufficient wall thickness and hardness to withstand distortion and excessive wear.¹⁾

3.2 Stand and horizontal vibration-free base, to support the funnel rigidly, e.g. as indicated in Figure 2.¹⁾

3.3 Balance, of sufficient capacity, capable of weighing the test portion to an accuracy of $\pm 0,05$ g.

3.4 Stopwatch, capable of measuring the elapsed time to an accuracy of $\pm 0,1$ s.

3.5 Chinese emery grit, a reference powder used for calibration of the funnel.¹⁾

1) Apparatus complying with 3.1 and 3.2, and standard Chinese emery grit can be purchased from ACuPowder International, LLC, 901 Lehigh Avenue, Union, NJ 07083, USA. This information is given for the convenience of users of this International Standard and does not constitute an endorsement by ISO of the company named above. Equivalent products may be used if they can be shown to lead to the same results.

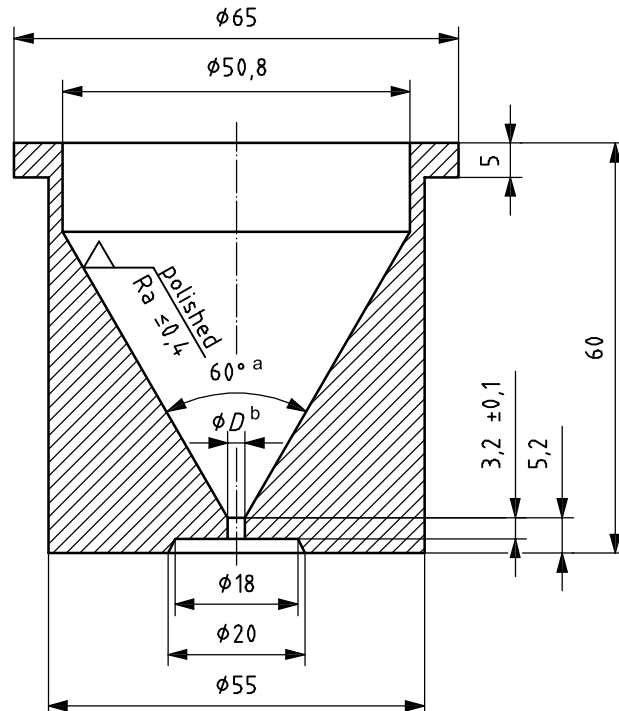

iTeh STANDARD PREVIEW
(standards.iteh.ai)

Key

^a This value is mandatory.

^b $D = 2,5^{+0,2}_0$.

ISO 4490:2008

Figure 1 — Calibrated funnel (Hall flowmeter)
<http://standards.iteh.ai/catalog/standards/sist/4e8f900b-851fc86d108d/iso-4490-2008>

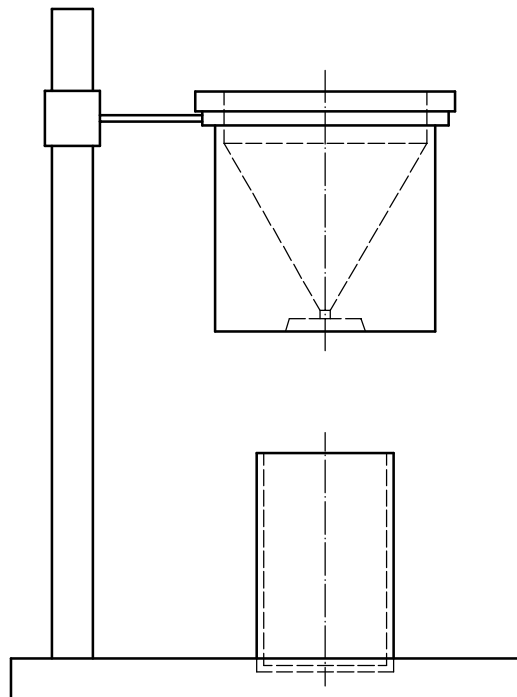

Figure 2 — Arrangement of calibrated funnel and stand

4 Calibration of the funnel

4.1 Calibration by the manufacturer of the funnel

The manufacturer shall supply the flowmeter calibrated as follows.

- a) Dry the Chinese emery grit (3.5) in an open and clean glass jar at 110 °C for 60 min in air.
- b) Cool the emery to room temperature in a desiccator.
- c) Weigh out 50 g of the emery grit.
- d) Follow the procedure outlined in Clause 6.
- e) Repeat the procedure with the same 50 g mass of emery, until there are five determinations within 0,4 s.
- f) The average of these five determinations is stamped on the bottom of the funnel and shall be within $40,0 \pm 0,5$ s.

The Chinese emery grit used as the reference powder replaces the Turkish emery grit from the 1978 edition of this International Standard, as the latter is no longer available. The Chinese emery has been found to be more sensitive and the instructions should therefore be followed carefully.

4.2 Calibration by the user of the funnel

The flow rate of the reference sample shall be determined by the above method. If the flow rate has changed to be outside $40,0 \pm 0,5$ s, a correction factor must be used when measuring different powders. This correction factor is obtained by dividing 40,0 by this new value for the Chinese emery grit.

It is recommended that the users periodically verify whether a correction is needed or not.

It is recommended that, before a correction factor is adopted, the cause of the change be investigated. If the flow rate has decreased, it is probable that repeated use has burnished the orifice and a (new) correction factor is justified. An increase in flow rate may indicate a coating of soft powder on the orifice. This coating should be carefully removed and the calibration test repeated.

It is recommended that the use of a funnel be discontinued after the duration of flow of the reference sample has decreased to less than 37 s.

5 Sampling

5.1 The mass of the test sample shall be at least 200 g.

5.2 In general, the powder shall be tested in the as-received condition. In certain cases, and after agreement between the supplier and user, the powder may be dried. However, if the powder is susceptible to oxidation, the drying shall take place in a vacuum or in inert gas. If the powder contains volatile substances, it shall not be dried.

5.3 Immediately before the test, weigh out a $50 \pm 0,1$ g test portion.

5.4 The determination shall be carried out on three test portions.

6 Procedure

Transfer the test portion to the funnel, keeping the discharge orifice closed by a dry finger. Take care that the stem of the funnel is filled with powder. Start the stopwatch (3.4) when the orifice is opened and stop it at the instant when the last of the powder leaves the orifice. Record the elapsed time measured to the nearest 0,1 s.

Alternatively, the orifice can be kept open, when the test portion is transferred to the funnel with the rest of the procedure being the same.

NOTE If the powder does not begin to flow when the orifice is opened, one slight tap on the funnel to start the flow is permitted. If this has no effect, or if the flow stops during the test, the powder is considered to possess no flowability according to the test method described in this International Standard.

7 Expression of results

Calculate the arithmetic mean of the results of the three determinations and report the value in seconds per 50 g, rounded to the nearest second. If a correction factor (see 4.2) should be used, the average shall be multiplied by this correction factor.

8 Precision

There are no relevant data available for this issue.

iTeh STANDARD PREVIEW
(standards.iteh.ai)

9 Test report

The test report shall include the following information:

- a) a reference to this International Standard, i.e. ISO 4490:2008;
<https://standards.iteh.ai/catalog/standards/sist/eb5c5721-048b-4e8f-900b-8511c86d108d/iso-4490-2008>
- b) all details for identification of the test sample;
- c) the result obtained;
- d) the use of an open orifice;
- e) all operations not specified by this International Standard, or regarded as optional (e.g. the drying procedure applied and whether flow has been induced by tapping the funnel);
- f) details of any occurrence which may have affected the result.

iTeh STANDARD PREVIEW
(standards.iteh.ai)

ISO 4490:2008

<https://standards.iteh.ai/catalog/standards/sist/eb5c5721-048b-4e8f-900b-851fc86d108d/iso-4490-2008>