**Rubber, vulcanized or thermoplastic —
Determination of tear strength —**

Part 1:

Trouser, angle and crescent test pieces

*Caoutchouc vulcanisé ou thermoplastique — Détermination de la
résistance au déchirement —*

iTeh STANDARD PREVIEW
(standards.iteh.ai)
Partie 1: Éprouvettes pantalon, angulaire et croissant

ISO 34-1:2010

<https://standards.iteh.ai/catalog/standards/sist/ab5e72b4-3cbe-43fe-8f97-478109271089/iso-34-1-2010>



PDF disclaimer

This PDF file may contain embedded typefaces. In accordance with Adobe's licensing policy, this file may be printed or viewed but shall not be edited unless the typefaces which are embedded are licensed to and installed on the computer performing the editing. In downloading this file, parties accept therein the responsibility of not infringing Adobe's licensing policy. The ISO Central Secretariat accepts no liability in this area.

Adobe is a trademark of Adobe Systems Incorporated.

Details of the software products used to create this PDF file can be found in the General Info relative to the file; the PDF-creation parameters were optimized for printing. Every care has been taken to ensure that the file is suitable for use by ISO member bodies. In the unlikely event that a problem relating to it is found, please inform the Central Secretariat at the address given below.

iTeh STANDARD PREVIEW
(standards.iteh.ai)

[ISO 34-1:2010](https://standards.iteh.ai/catalog/standards/sist/ab5e72b4-3cbe-43fe-8f97-478109271089/iso-34-1-2010)

<https://standards.iteh.ai/catalog/standards/sist/ab5e72b4-3cbe-43fe-8f97-478109271089/iso-34-1-2010>



COPYRIGHT PROTECTED DOCUMENT

© ISO 2010

All rights reserved. Unless otherwise specified, no part of this publication may be reproduced or utilized in any form or by any means, electronic or mechanical, including photocopying and microfilm, without permission in writing from either ISO at the address below or ISO's member body in the country of the requester.

ISO copyright office
Case postale 56 • CH-1211 Geneva 20
Tel. + 41 22 749 01 11
Fax + 41 22 749 09 47
E-mail copyright@iso.org
Web www.iso.org

Published in Switzerland

Contents

Page

Foreword	iv
1 Scope	1
2 Normative references	2
3 Terms and definitions	2
4 Principle.....	2
5 Apparatus	3
5.1 Dies	3
5.2 Nick cutter	3
5.3 Testing machine	3
5.4 Grips	3
6 Calibration	5
7 Test piece	6
8 Number of test pieces	6
9 Temperature of test	6
10 Procedure	7
11 Expression of results	7
12 Test report	7
Annex A (informative) Precision	9
Annex B (normative) Calibration schedule	11
Bibliography.....	13

ITeH STANDARD PREVIEW
(standards.iteh.ai)

[ISO 34-1:2010](https://standards.iteh.ai/catalog/standards/sist/ab5e72b4-3cbe-43fe-8f97-478109271089/iso-34-1-2010)

<https://standards.iteh.ai/catalog/standards/sist/ab5e72b4-3cbe-43fe-8f97-478109271089/iso-34-1-2010>

Foreword

ISO (the International Organization for Standardization) is a worldwide federation of national standards bodies (ISO member bodies). The work of preparing International Standards is normally carried out through ISO technical committees. Each member body interested in a subject for which a technical committee has been established has the right to be represented on that committee. International organizations, governmental and non-governmental, in liaison with ISO, also take part in the work. ISO collaborates closely with the International Electrotechnical Commission (IEC) on all matters of electrotechnical standardization.

International Standards are drafted in accordance with the rules given in the ISO/IEC Directives, Part 2.

The main task of technical committees is to prepare International Standards. Draft International Standards adopted by the technical committees are circulated to the member bodies for voting. Publication as an International Standard requires approval by at least 75 % of the member bodies casting a vote.

Attention is drawn to the possibility that some of the elements of this document may be the subject of patent rights. ISO shall not be held responsible for identifying any or all such patent rights.

ISO 34-1 was prepared by Technical Committee ISO/TC 45, *Rubber and rubber products*, Subcommittee SC 2, *Testing and analysis*.

This third edition cancels and replaces the second edition (ISO 34-1:2004), which has been technically revised. In 5.3 the force-measuring accuracy of the tensile-testing machine has been changed to class 1. In Clause 10, the permissible range of the median thickness of each group for comparative purposes has also been changed.

ISO 34-1:2010

ISO 34 consists of the following parts, under the general title *Rubber, vulcanized or thermoplastic — Determination of tear strength*:

- *Part 1: Trouser, angle and crescent test pieces*
- *Part 2: Small (Delft) test pieces*

Rubber, vulcanized or thermoplastic — Determination of tear strength —

Part 1: Trouser, angle and crescent test pieces

WARNING — Persons using this part of ISO 34 should be familiar with normal laboratory practice. This part of ISO 34 does not purport to address all of the safety problems, if any, associated with its use. It is the responsibility of the user to establish appropriate safety and health practices and to ensure compliance with any national regulatory conditions.

CAUTION — Certain procedures specified in this part of ISO 34 may involve the use or generation of substances, or the generation of waste, that could constitute a local environmental hazard. Reference should be made to appropriate documentation on safe handling and disposal after use.

1 Scope

iTeh STANDARD PREVIEW

This part of ISO 34 specifies three test methods for the determination of the tear strength of vulcanized or thermoplastic rubber, namely:

- method A, using a trouser test piece; [ISO 34-1:2010](https://standards.iteh.ai/catalog/standards/sist/ab5e72b4-3cbe-43fe-8f97-478109271089/iso-34-1-2010)
- method B, using an angle test piece, with or without a nick of specified depth;
- method C, using a crescent test piece with a nick.

The value of tear strength obtained depends on the shape of the test piece, speed of stretching, and temperature of test. It can also be susceptible to grain effects in rubber.

Method A: Using a trouser test piece

Method A, using the trouser test piece, is preferred because it is not sensitive to the length of the cut, unlike the other two test pieces in which the nick has to be very closely controlled. In addition, the results obtained are more easily related to the fundamental tear properties of the material and are less sensitive to modulus effects (provided that the leg extension is negligible) and the rate of propagation of the tear is directly related to the rate of grip separation. With some rubbers, the propagation of tear is not smooth (knotty tear), and analysis of results can be difficult^[3].

Method B, procedure (a): Using an angle test piece without nick

This test is a combination of tear initiation and propagation. Stress is built up at the point of the angle until it is sufficient to initiate a tear and then further stresses propagate this tear. However, it is only possible to measure the overall force required to rupture the test piece, and, therefore, the force cannot be resolved in two components producing initiation and propagation^[4].

Method B, procedure (b): Using an angle test piece with nick

This test measures the force required to propagate a nick already produced in the test piece. The rate of propagation is not directly related to the jaw speed^[5].

Method C: Using a crescent test piece

This test also measures the force required to propagate a nick already produced in the test piece, and the rate of propagation is not related to the jaw speed.

NOTE A separate method for the determination of the tear strength of small test pieces of rubber (Delft test pieces) is specified in ISO 34-2^[1].

2 Normative references

The following referenced documents are indispensable for the application of this document. For dated references, only the edition cited applies. For undated references, the latest edition of the referenced document (including any amendments) applies.

ISO 5893, *Rubber and plastics test equipment — Tensile, flexural and compression types (constant rate of traverse) — Specification*

ISO 6133, *Rubber and plastics — Analysis of multi-peak traces obtained in determinations of tear strength and adhesion strength*

ISO 18899:2004, *Rubber — Guide to the calibration of test equipment*

ISO 23529, *Rubber — General procedures for preparing and conditioning test pieces for physical test methods*

3 Terms and definitions

ITeh STANDARD PREVIEW
(standards.iteh.ai)

For the purposes of this document, the following terms and definitions apply.

3.1 trouser tear strength

median force required to propagate a cut in a specified trouser-shaped test piece by tearing, divided by the thickness of the test piece, the force acting in a direction substantially in the plane of the cut

NOTE The median force is calculated in accordance with ISO 6133.

3.2 unnicked angle tear strength

maximum force required to rupture a specified angle-shaped test piece, divided by the thickness of the test piece, the force acting in a direction substantially along the length of the test piece

3.3 nicked angle tear strength crescent tear strength

maximum force required to cause a nick cut in a specified angle- or crescent-shaped test piece to extend by tearing of the rubber, divided by the thickness of the test piece, the force acting in a direction substantially normal to the plane of the nick

4 Principle

The test consists in measuring the force required to tear a specified test piece, in continuation of the cut or nick already produced in the test piece or, in the case of method B, procedure (a), completely across the width of the test piece.

The tearing force is applied by means of a tensile testing machine, operated without interruption at a constant rate of traverse until the test piece breaks. Dependent upon the method employed, the maximum or median force achieved is used to calculate the tear strength.

No correlation between data obtained by the alternative test pieces is implied.

5 Apparatus

5.1 Dies

5.1.1 The die used for cutting trouser test pieces shall have the dimensions shown in Figure 1.

5.1.2 The die used for cutting angle test pieces shall have the dimensions shown in Figure 2.

5.1.3 The die used for cutting crescent test pieces shall have the dimensions shown in Figure 3.

5.1.4 The cutting edges of the dies shall be kept sharp and free from ragged edges. Care shall be taken that the cutting edges are perpendicular to the other surfaces of the die and have a minimum of concavity.

5.2 Nick cutter

A sharp razor blade or a sharp knife free from ragged edges shall be used for producing a cut or a nick in the test piece.

The apparatus for introducing the nick required for the nicked angle or crescent test piece shall be as follows.

Means shall be provided for clamping the test piece firmly, especially in the region where the nick is to be introduced. The cutting tool, consisting of a razor blade or similar blade, shall be clamped in a plane perpendicular to the major axis of the test piece, and positioned so as to introduce the nick in the appropriate place. The blade clamping device shall permit no lateral movement and shall be fitted in guides to enable the blade to be moved across the test piece with its edge remaining perpendicular to the plane of the test piece. Alternatively, the blade shall be fixed and the test piece arranged to move in an analogous manner. Means shall be provided for fine adjustment of the depth of the nick. The adjustment of the position of the blade holder or clamped test piece shall be determined for each blade by cutting one or two preliminary nicks and measuring these with the aid of a microscope. The blade shall be wetted with water or soap solution prior to nicking.

ISO 34-1:2010

NOTE A suitable apparatus for nicking tear test pieces has been described in detail in the literature^[6].

478109271089/iso-34-1-2010

To check that the depth of the nick is within the specified limits (see 7.4), any suitable means can be used, e.g. an optical projection apparatus. A convenient arrangement is a microscope giving at least 10× magnification fitted with a travelling stage suitably illuminated. The eyepiece is fitted with a graticule or crosswire by which to record the travel of the stage and test piece through a distance equal to the depth of the nick. The travel of the stage is calibrated with a stage micrometer.

Alternatively, a travelling microscope can be used.

The apparatus shall have an accuracy of measurement of 0,05 mm.

5.3 Testing machine

The machine shall conform to the requirements of ISO 5893, to an accuracy corresponding to class 1.

It shall be capable of registering the applied forces within 1 % during the test while maintaining the specified constant rate of separation of the jaws of 100 mm/min ± 10 mm/min for the trouser test piece and 500 mm/min ± 50 mm/min for the angle and crescent test pieces. A low-inertia machine having autographic force-recording facilities is essential when using the trouser test piece.

5.4 Grips

The machine shall be provided with a type of grip which tightens automatically as the tension increases and exerts a uniform pressure across the widened end of the test piece. Each grip shall incorporate a means for positioning so that the test pieces are inserted symmetrically and in axial alignment with the direction of the pull. The depth of insertion shall be such that the test piece is adequately gripped, within the parallel-sides portion, when testing angle and crescent test pieces. Trouser test pieces shall be inserted in the grips in accordance with Figure 4.

Dimensions in millimetres

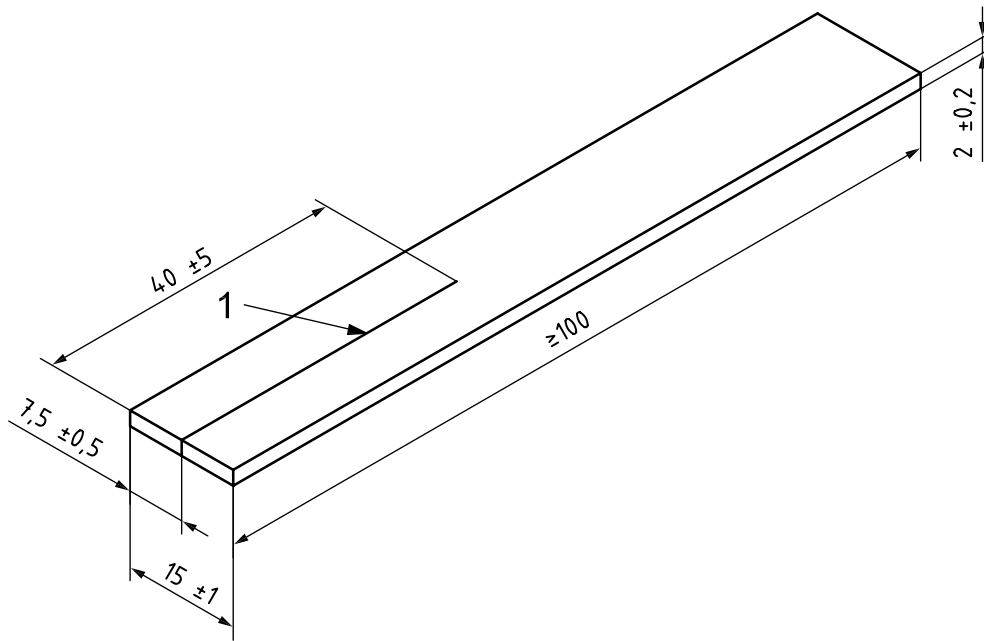

Key

- 1 location of cut

iTeh STANDARD PREVIEW
(standards.iteh.ai)

Figure 1 — Trouser test piece die

ISO 34-1:2010

<https://standards.iteh.ai/catalog/standards/sist/ab5e72b4-3cbe-43fe-8f97-478109271089/iso-34-1-2010>

Dimensions in millimetres

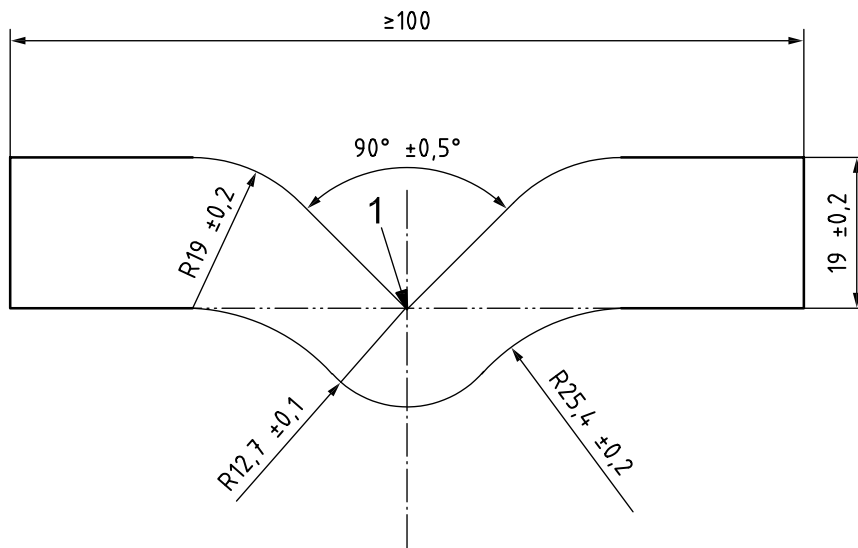

Key

- 1 location of nick for method B, procedure (b)

Figure 2 — Angle test piece die

Dimensions in millimetres

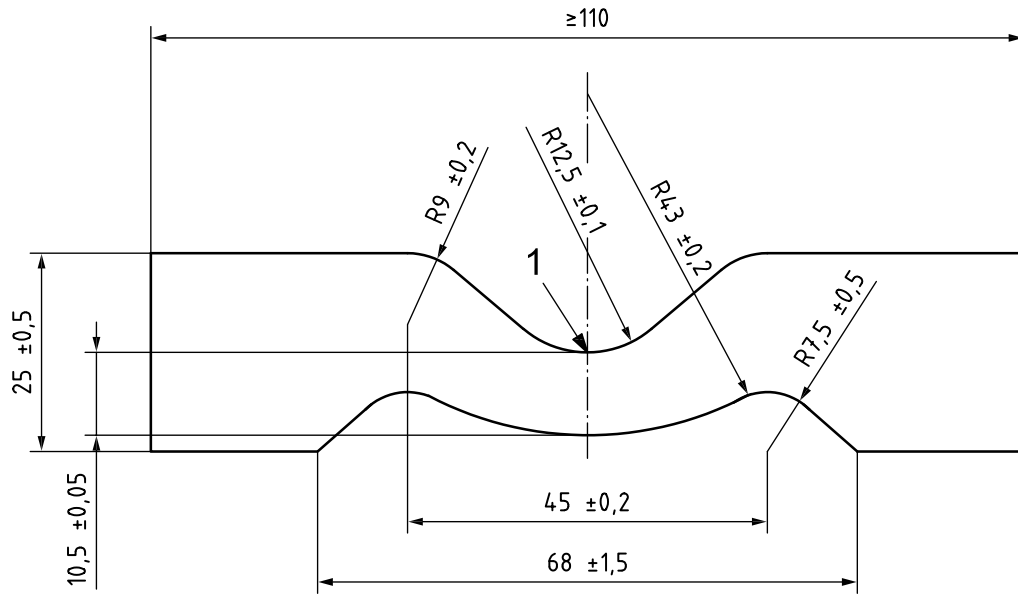

Key

- 1 location of nick

iTeh STANDARD PREVIEW
Figure 3 — Crescent test piece die
(standards.iteh.ai)

ISO 34-1:2010
<https://standards.iteh.ai/catalog/standards/sist/ab5e72b4-3cbe-43fe-8f97-478109271089/iso-34-1-2010>

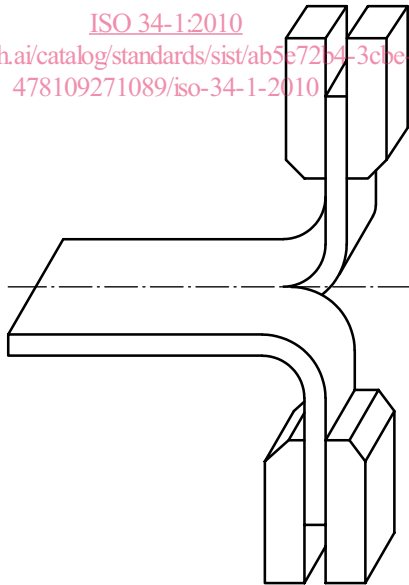

Figure 4 — Positioning of trouser test piece in testing machine

6 Calibration

The test apparatus shall be calibrated in accordance with the schedule given in Annex B.