

---

---

**Rubber, vulcanized or thermoplastic —  
Determination of abrasion resistance  
using a rotating cylindrical drum device**

*Caoutchouc vulcanisé ou thermoplastique — Détermination de la  
résistance à l'abrasion à l'aide d'un dispositif à tambour tournant*

**iTeh STANDARD PREVIEW**  
**(standards.iteh.ai)**

[ISO 4649:2010](https://standards.iteh.ai/catalog/standards/sist/8ea5f544-86be-4cb2-8cab-37bc32b844d2/iso-4649-2010)

<https://standards.iteh.ai/catalog/standards/sist/8ea5f544-86be-4cb2-8cab-37bc32b844d2/iso-4649-2010>



**PDF disclaimer**

This PDF file may contain embedded typefaces. In accordance with Adobe's licensing policy, this file may be printed or viewed but shall not be edited unless the typefaces which are embedded are licensed to and installed on the computer performing the editing. In downloading this file, parties accept therein the responsibility of not infringing Adobe's licensing policy. The ISO Central Secretariat accepts no liability in this area.

Adobe is a trademark of Adobe Systems Incorporated.

Details of the software products used to create this PDF file can be found in the General Info relative to the file; the PDF-creation parameters were optimized for printing. Every care has been taken to ensure that the file is suitable for use by ISO member bodies. In the unlikely event that a problem relating to it is found, please inform the Central Secretariat at the address given below.

**iTeh STANDARD PREVIEW**  
**(standards.iteh.ai)**

[ISO 4649:2010](#)

<https://standards.iteh.ai/catalog/standards/sist/8ea5f544-86be-4cb2-8cab-37bc32b844d2/iso-4649-2010>



**COPYRIGHT PROTECTED DOCUMENT**

© ISO 2010

All rights reserved. Unless otherwise specified, no part of this publication may be reproduced or utilized in any form or by any means, electronic or mechanical, including photocopying and microfilm, without permission in writing from either ISO at the address below or ISO's member body in the country of the requester.

ISO copyright office  
Case postale 56 • CH-1211 Geneva 20  
Tel. + 41 22 749 01 11  
Fax + 41 22 749 09 47  
E-mail [copyright@iso.org](mailto:copyright@iso.org)  
Web [www.iso.org](http://www.iso.org)

Published in Switzerland

## Contents

Page

|   |    |
|---|----|
| Foreword .....  | iv |
| 1 Scope .....   | 1  |
| 2 Normative references .....  | 1  |
| 3 Terms and definitions .....   | 2  |
| 4 Principle.....  | 2  |
| 5 Apparatus and materials.....  | 4  |
| 6 Calibration .....   | 5  |
| 7 Test pieces .....   | 6  |
| 8 Test temperature .....  | 6  |
| 9 Procedure .....   | 7  |
| 10 Expression of results .....  | 8  |
| 11 Precision.....   | 9  |
| 12 Test report .....  | 9  |
| Annex A (normative) Notes on a suitable abrasive sheet .....            | 10 |
| Annex B (normative) Standard and user-defined reference compounds ..... | 11 |
| Annex C (normative) Calibration schedule .....                          | 15 |
| Annex D (informative) Precision and bias .....                          | 17 |
| Bibliography.....   | 19 |

## Foreword

ISO (the International Organization for Standardization) is a worldwide federation of national standards bodies (ISO member bodies). The work of preparing International Standards is normally carried out through ISO technical committees. Each member body interested in a subject for which a technical committee has been established has the right to be represented on that committee. International organizations, governmental and non-governmental, in liaison with ISO, also take part in the work. ISO collaborates closely with the International Electrotechnical Commission (IEC) on all matters of electrotechnical standardization.

International Standards are drafted in accordance with the rules given in the ISO/IEC Directives, Part 2.

The main task of technical committees is to prepare International Standards. Draft International Standards adopted by the technical committees are circulated to the member bodies for voting. Publication as an International Standard requires approval by at least 75 % of the member bodies casting a vote.

Attention is drawn to the possibility that some of the elements of this document may be the subject of patent rights. ISO shall not be held responsible for identifying any or all such patent rights.

ISO 4649 was prepared by Technical Committee ISO/TC 45, *Rubber and rubber products*, Subcommittee SC 2, *Testing and analysis*.

This third edition cancels and replaces the second edition (ISO 4649:2002), which has been technically revised. The main changes concern the addition of a calibration schedule (see Annex C), updating the normative references and moving the precision statement to Annex D.

[ISO 4649:2010](https://standards.iteh.ai/catalog/standards/sist/8ea5f544-86be-4cb2-8cab-37bc32b844d2/iso-4649-2010)

<https://standards.iteh.ai/catalog/standards/sist/8ea5f544-86be-4cb2-8cab-37bc32b844d2/iso-4649-2010>

# Rubber, vulcanized or thermoplastic — Determination of abrasion resistance using a rotating cylindrical drum device

**WARNING** — Persons using this International Standard should be familiar with normal laboratory practice. This standard does not purport to address all of the safety problems, if any, associated with its use. It is the responsibility of the user to establish appropriate safety and health practices and to ensure compliance with any national regulatory conditions.

**CAUTION** — Certain procedures specified in this International Standard may involve the use or generation of substances, or the generation of waste, that could constitute a local environmental hazard. Reference should be made to appropriate documentation on safe handling and disposal after use.

## 1 Scope

This International Standard specifies two methods for the determination of the resistance of rubber to abrasion by means of a rotating cylindrical drum device.

The methods involve determination of the volume loss due to the abrasive action of rubbing a test piece over a specified grade of abrasive sheet. Method A is for a non-rotating test piece and method B for a rotating test piece. For each method, the result can be reported as a relative volume loss or an abrasion resistance index.

Because factors such as the grade of abrasive sheet, the type of adhesive used in the manufacture of the sheet and contamination and wear caused by previous testing lead to variations in the absolute values of abrasion loss, all tests are comparative. Runs with a reference compound are included so that the results can be expressed either as a relative volume loss compared to a calibrated abrasive sheet or as an abrasion resistance index compared to a reference compound.

**NOTE** The abrasion loss is often more uniform using the rotating test piece because the whole surface of the test piece is in contact with the abrasive sheet over the duration of the test. However, there is considerable experience using the non-rotating test piece.

These test methods are suitable for comparative testing, quality control, specification compliance testing, referee purposes, and research and development work. No close relation between the results of this abrasion test and service performance can be inferred.

## 2 Normative references

The following referenced documents are indispensable for the application of this document. For dated references, only the edition cited applies. For undated references, the latest edition of the referenced document (including any amendments) applies.

ISO 2230, *Rubber products — Guidelines for storage*

ISO 2393, *Rubber test mixes — Preparation, mixing and vulcanization — Equipment and procedures*

ISO 2781, *Rubber, vulcanized or thermoplastic — Determination of density*

ISO 7619-1, *Rubber, vulcanized or thermoplastic — Determination of indentation hardness — Part 1: Durometer method (Shore hardness)*

ISO 9298:1995, *Rubber compounding ingredients — Zinc oxide — Test methods*

ISO 18899:2004, *Rubber — Guide to the calibration of test equipment*

ISO 23529, *Rubber — General procedures for preparing and conditioning test pieces for physical test methods*

### 3 Terms and definitions

For the purposes of this document, the following terms and definitions apply.

#### 3.1

##### **abrasion resistance**

resistance to wear by mechanical action upon a surface

NOTE For the purposes of this International Standard, the abrasion resistance is expressed either as a relative volume loss compared to an abrasive sheet calibrated using a standard reference compound, or as an abrasion resistance index compared to a reference compound.

#### 3.2

##### **relative volume loss**

$\Delta V_{rel}$

volume loss of the test rubber after being subjected to abrasion by an abrasive sheet which will cause a reference compound to lose a defined mass under the same specified conditions of test

NOTE 1 A value of 200 mg has been established as the mid-point of the calibration range (see B.2.4.3) for the abrasive sheet using method A with standard reference compound No. 1 (see B.2) and considerable experience has been accumulated using the relative volume loss calculation in 9.2. A relative volume loss can be calculated for method B (rotating test piece), or with either test method with another reference compound, if the defined mass loss is known. [150 mg has been indicated as a possible value for method B with standard reference compound No. 2 (see B.3), but its accuracy has not been documented to the degree of the value 200 mg using method A with standard reference compound No. 1 (see B.2).]

NOTE 2 Relative volume loss is expressed in cubic millimetres.

#### 3.3

##### **abrasion resistance index**

**ARI**

$I_{AR}$

ratio of the volume loss of a reference compound to the volume loss of the test rubber, measured under the same specified conditions of test and expressed as a percentage

NOTE A smaller number indicates a lower abrasion resistance.

### 4 Principle

A cylindrical rubber test piece is made to slide over an abrasive sheet of specified abrasive grade at a specified contact pressure over a given distance. The test piece may be non-rotating or rotating during the test.

Abrasion takes place over one of the end surfaces of the cylindrical test piece (see Figure 1). The abrasive sheet is attached to the surface of a rotating cylindrical drum against which the test piece is held and across which it is traversed.

The loss in mass of the test piece is determined and the volume loss is calculated from the density of the material used for the test piece. The volume loss of the test piece is compared to that of a reference compound tested under the same conditions.

A very important part of this method is the preparation of the abrasive sheet and its calibration using standard reference compound No. 1 (see B.2) with a non-rotating test piece.

Dimensions in millimetres

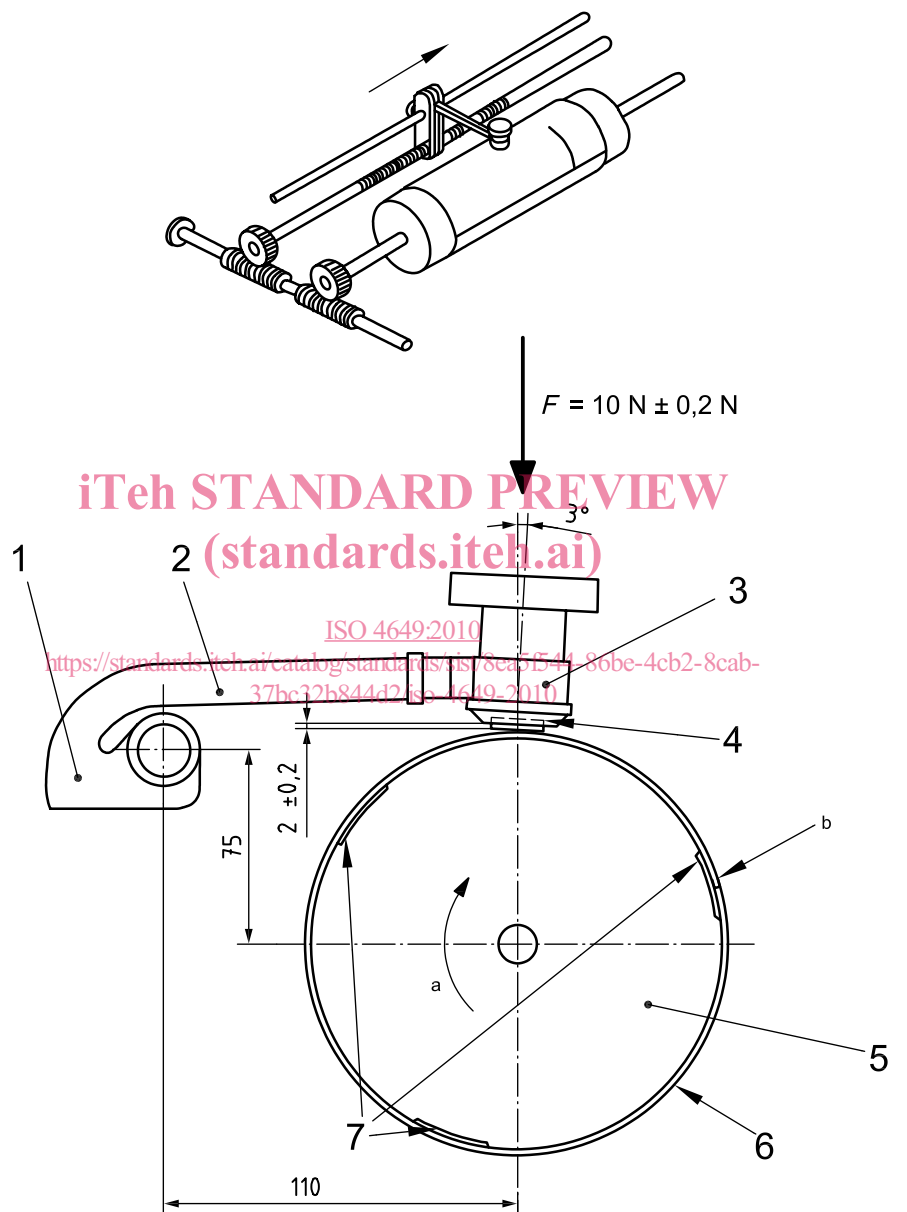

**Key**

- |   |  |
|---|--|
| 1 sledge  | 6 abrasive sheet                             |
| 2 swivel arm  | 7 double-sided adhesive tape                 |
| 3 test piece holder                                     | $F$ vertical force                           |
| 4 test piece  | $a$ Rotational speed 40 r/min $\pm$ 1 r/min. |
| 5 cylinder, diameter 150 mm $\pm$ 0,2 mm, length 500 mm | $b$ Gap of size $\leq$ 2 mm.                 |

**Figure 1 — Schematic illustration of apparatus**

## 5 Apparatus and materials

### 5.1 Abrasion machine

The test apparatus (see Figure 1) consists of a laterally movable test piece holder and a rotatable cylinder to which the abrasive sheet (5.2) is fixed.

The cylinder shall have a diameter of  $150 \text{ mm} \pm 0,2 \text{ mm}$  and a length of about 500 mm and shall be rotated at a speed of  $40 \text{ r/min} \pm 1 \text{ r/min}$ , the direction of rotation being as indicated in Figure 1.

The test piece holder shall have a cylindrical opening, the diameter of which can be adjusted from 15,5 mm to 16,3 mm, and a device for adjusting the length of the test piece protruding from the opening to  $2 \text{ mm} \pm 0,2 \text{ mm}$ . The holder shall be mounted on a swivel arm that, in turn, is attached to a sledge that can be moved laterally on a spindle. The lateral displacement of the holder shall be  $4,20 \text{ mm} \pm 0,04 \text{ mm}$  per revolution of the drum (see Note 1). Suitable attachments may be provided to rotate the test piece during the test run by rotation of the test piece holder (method B), preferably at the rate of 1 revolution per 50 revolutions of the drum.

NOTE 1 With this lateral movement, the test piece passes over any one area of the abrasive sheet four times.

The central axis of the holder shall have an inclination of  $3^\circ$  to the perpendicular in the direction of rotation (see Figure 1), and shall be placed directly above the longitudinal axis of the cylinder to within  $\pm 1 \text{ mm}$ .

The swivel arm and test piece holder shall be free from vibration during operation, and so disposed that the test piece is pressed against the drum with a vertical force of  $10 \text{ N} \pm 0,2 \text{ N}$ . For investigation of extremely soft or hard materials, the force may be changed to  $5 \text{ N} \pm 0,1 \text{ N}$  or  $20 \text{ N} \pm 0,4 \text{ N}$  respectively (see Note 2). The force is generated by adding masses to the top of the test piece holder.

NOTE 2 A force of 5 N is typically used for rubbers softer than approximately 40 IRHD and a force of 20 N is used for hard rubbers of 80 IRHD and above.

The abrasive sheet shall be attached to the drum using three evenly spaced strips of double-sided adhesive tape extending along the complete length of the drum. The width of the margins that are not touched by the test piece shall be equal. Care shall be taken to ensure that the abrasive sheet is firmly held so as to present a uniform abrasive surface over the whole area of the cylinder. One of the strips shall be placed where the ends of the abrasive sheet meet. Ideally, the ends should meet exactly, but any gap left between them shall not exceed 2 mm. The adhesive tape shall be about 50 mm wide and not more than 0,2 mm thick.

The abrasion run starts by bringing the test piece into contact with the abrasion sheet.

Placement of the test piece on the sheet at the beginning of a test run, and its removal after an abrasion run of  $40 \text{ m} \pm 0,2 \text{ m}$  (equivalent to 84 revolutions), shall be automatic. In special cases of very high volume loss of the test piece, the abrasion distance may be reduced to  $20 \text{ m} \pm 0,1 \text{ m}$  (equivalent to 42 revolutions). In that case, a revolution counter or automatic stopping device should preferably be used.

NOTE 3 For rubbers with very high mass loss, a distance of 10 m has been used.

To protect the abrasive sheet from damage by the test piece holder, a device for switching off the apparatus just before the lower edge of the test piece holder touches the sheet is recommended.

The test machine may be equipped with a vacuum hose and a brush to aid in the removal of debris from the machine.

### 5.2 Abrasive sheet

Abrasive sheet made with aluminium oxide of grain size 60, at least 400 mm wide,  $474 \text{ mm} \pm 1 \text{ mm}$  long, and 1 mm average thickness, shall be used as the abrasive medium.

In a test using a non-rotating test piece of standard reference compound No. 1 (see B.2), this abrasive sheet shall cause a mass loss of between 180 mg and 220 mg for an abrasion distance of 40 m.



When each new sheet is first used, the direction of motion shall be indicated on the sheet, as it is important that the same direction be used for all subsequent test runs.

Notes on a suitable abrasive sheet are given in Annex A.

### 5.3 Hollow drill (see Figure 2)

The drill shown in Figure 2 is an example of a tool suitable for the preparation of test pieces that are not moulded (see 7.1). The speed of rotation of the drill needs to be at least 1 000 r/min for most rubbers, and even higher for rubbers with a hardness of less than 50 IRHD. A sufficient cooling of the tool is necessary to prevent an undesired heating of the drill.

Dimensions in millimetres

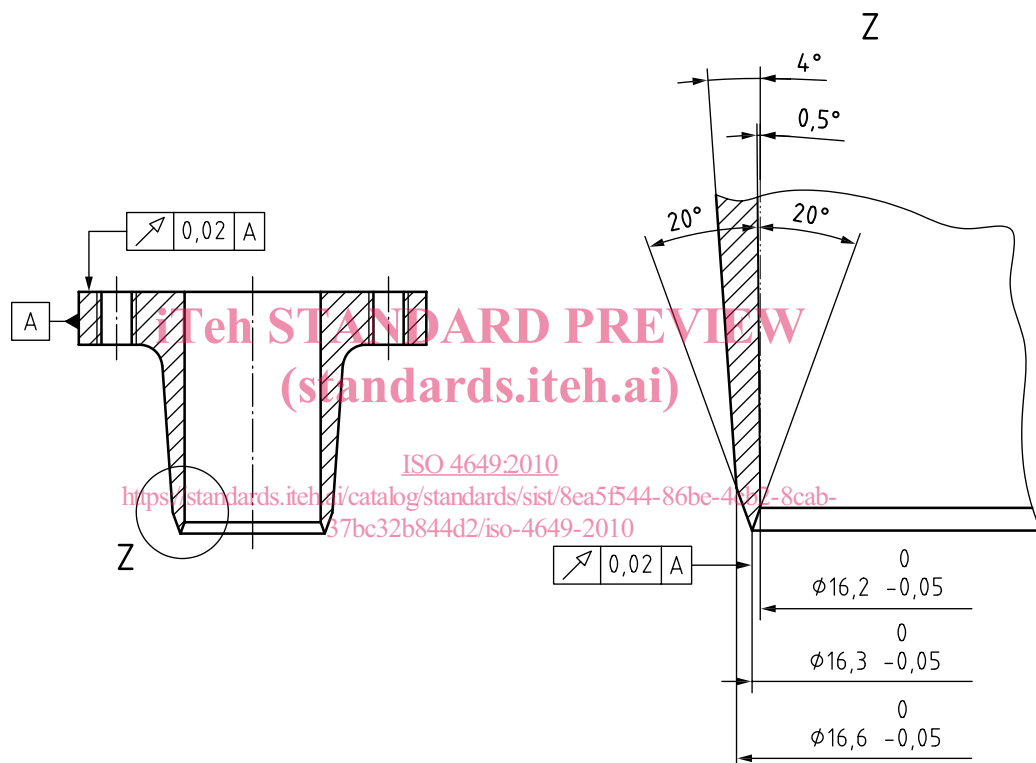

Figure 2 — Example of a hollow drill for test piece preparation

### 5.4 Balance

The balance shall be of sufficient accuracy to enable the mass loss of a test piece to be determined to  $\pm 1$  mg.

### 5.5 Standard reference compounds

Specifications for standard reference compounds are given in detail in Annex B.

## 6 Calibration

The test apparatus shall be calibrated in accordance with the schedule given in Annex C.

## 7 Test pieces

### 7.1 Type and preparation

The test pieces shall be cylindrical in shape, of diameter  $16 \text{ mm} \pm 0,2 \text{ mm}$ , with a minimum height of 6 mm.

Test pieces are normally prepared from moulded sheet using the hollow drill (5.3) or other rotating cutting tool. During cutting, the cutting edge shall be lubricated with water to which a wetting agent has been added. Punching of the test pieces is not permitted.

NOTE If the cut sample is not satisfactory, cylinder vibration occurs.

Alternatively, test pieces may be vulcanized or formed in a mould.

If test pieces of the required thickness are not available, the necessary thickness may be obtained by bonding a piece of the test rubber to a base element of hardness not less than 80 IRHD. The thickness of the test rubber shall be not less than 2 mm.

### 7.2 Number

A minimum of three test runs shall be carried out for each rubber being tested. A new test piece shall be used for each test run. For referee purposes, use 10 test pieces.

In the case of the standard reference compounds No. 1 (see B.2) and No. 2 (see B.3), three test runs may be carried out on one test piece in order to reduce wastage.

### 7.3 Time interval between vulcanization or forming and testing

For all test purposes, the minimum time between vulcanization or forming and testing shall be 16 h. For non-product tests, the maximum time between vulcanization and testing shall be 4 weeks and, for evaluations intended to be comparable, the tests, as far as possible shall be carried out after the same time interval. For product tests, whenever possible, the time between vulcanization or forming and testing shall not exceed 3 months. In other cases, tests shall be made within 2 months of the date of receipt of the product by the customer.

### 7.4 Conditioning

Condition all test pieces at standard laboratory temperature, in accordance with ISO 23529, for a minimum period of 16 h immediately before testing.

For rubbers which are sensitive to moisture, the humidity should also be controlled.

## 8 Test temperature

The test shall be carried out at standard laboratory temperature (see ISO 23529).

During a test run, there may be a considerable increase in temperature at the abrading interface, which may lead to temperature rises within the test piece. For the purposes of this International Standard, such temperature rises are to be disregarded, the temperature of test being that of the ambient atmosphere and of the test piece before commencing the test.

## 9 Procedure

### 9.1 General test procedure

Before each test, any rubber debris left on the abrasive sheet from a previous abrasion test shall be removed with a brush. A brush of about 55 mm diameter with hard nylon or similar bristles (see Note 1) and about 70 mm in length is recommended for this purpose. In some cases, a blank test with a reference compound (see Note 1) will effectively clean the abrasive sheet (see Note 2).

Brushes with metal bristles are not recommended as they shorten the life of the abrasive sheet.

NOTE 1 Reference compound used only for cleaning purposes does not necessarily have to meet the stringent requirements of the reference compound used for test purposes.

NOTE 2 Some laboratories have found that blowing removes the debris left by some test rubbers better than brushing. Safety blow guns which give a maximum pressure of 0,2 MPa at the nozzle when the nozzle is blocked off, used with a supply air pressure between 0,5 MPa and 0,9 MPa, have given good results.

For method A, the non-rotating test piece shall be used. For method B, the rotating test piece shall be used. Standard reference compound No. 1 (see B.2) or No. 2 (see B.3) or a user-defined reference compound shall be used as the reference compound. The method and the reference compound used shall be stated in the test report, because the results obtained can differ. For measurements intended to be comparable, the same conditions shall be used for all test rubbers and the reference compound.

Weigh the test piece to the nearest 1 mg. Fix the test piece in the test piece holder in such a way that a length of  $2,0 \text{ mm} \pm 0,2 \text{ mm}$  protrudes from the opening. This length shall be checked by means of a gauge.

The test piece shall normally be pressed against the drum with a vertical force of  $10 \text{ N} \pm 0,2 \text{ N}$ . If, for special cases, the vertical force is reduced to  $5 \text{ N} \pm 0,1 \text{ N}$  or increased to  $20 \text{ N} \pm 0,4 \text{ N}$ , this shall be stated in the test report.

ISO 4649:2010

<https://standards.iteh.ai/catalog/standards/sist/8ea5f544-86be-4cb2-8cab-316e2094128c/iso-4649-2010>

Turn on the suction, if it is provided. Move the test piece holder and sledge to the starting point and start the automatically controlled test run. Check for vibration in the test piece holder. This test method does not yield meaningful results if there is abnormal vibration in the test piece holder. The test run is stopped automatically after an abrasion distance of 40 m. When relatively large mass losses (usually more than 400 mg in 40 m) occur, the test run may be stopped after 20 m, and the length of exposed test piece reset to  $2,0 \text{ mm} \pm 0,2 \text{ mm}$  so that the remaining 20 m of the run may be completed. At no time shall the height of the test piece be less than 5 mm. If the mass loss is greater than 600 mg in 40 m, the abrasion distance shall be reduced to 20 m and this shall be stated in the test report. The results shall be multiplied by 2 so that the mass loss can still be given for an abrasion distance of 40 m.

For non-rotating test pieces that are removed during the test, care shall be taken to ensure that the test piece is always replaced in the test piece holder in the same way.

For bonded test pieces, care shall be taken that the test pieces are not abraded down to the bond line or if a sample with a fabric reinforcement is used in fabric line (if necessary, use a 20 m run).

Weigh the test piece to the nearest 1 mg after the test run. Sometimes a small edge hanging from the test piece has to be pulled off before weighing, especially if a non-rotating test piece is used.

Carry out all test runs on the same rubber consecutively.

### 9.2 Comparison against standard reference compounds or user-defined reference compounds

The test rubbers are compared against one of the two standard reference compounds specified in Annex B or a user-defined reference compound.