**Rubber, vulcanized or thermoplastic —
Determination of indentation hardness —**

**Part 2:
IRHD pocket meter method**

*Caoutchouc vulcanisé ou thermoplastique — Détermination de la dureté
par pénétration*

iTeh STANDARD PREVIEW
(standards.iteh.ai)

Partie 2: Méthode au duromètre de poche étalonné en DIDC

ISO 7619-2:2010

<https://standards.iteh.ai/catalog/standards/sist/9ff64601-e1eb-4a68-9210-9997c96c3a03/iso-7619-2-2010>



PDF disclaimer

This PDF file may contain embedded typefaces. In accordance with Adobe's licensing policy, this file may be printed or viewed but shall not be edited unless the typefaces which are embedded are licensed to and installed on the computer performing the editing. In downloading this file, parties accept therein the responsibility of not infringing Adobe's licensing policy. The ISO Central Secretariat accepts no liability in this area.

Adobe is a trademark of Adobe Systems Incorporated.

Details of the software products used to create this PDF file can be found in the General Info relative to the file; the PDF-creation parameters were optimized for printing. Every care has been taken to ensure that the file is suitable for use by ISO member bodies. In the unlikely event that a problem relating to it is found, please inform the Central Secretariat at the address given below.

iTeh STANDARD PREVIEW
(standards.iteh.ai)

ISO 7619-2:2010

<https://standards.iteh.ai/catalog/standards/sist/9ff64601-e1eb-4a68-9210-9997c96c3a03/iso-7619-2-2010>



COPYRIGHT PROTECTED DOCUMENT

© ISO 2010

All rights reserved. Unless otherwise specified, no part of this publication may be reproduced or utilized in any form or by any means, electronic or mechanical, including photocopying and microfilm, without permission in writing from either ISO at the address below or ISO's member body in the country of the requester.

ISO copyright office
Case postale 56 • CH-1211 Geneva 20
Tel. + 41 22 749 01 11
Fax + 41 22 749 09 47
E-mail copyright@iso.org
Web www.iso.org

Published in Switzerland

Contents

Page

Foreword	iv
Introduction.....	v
1 Scope	1
2 Normative references	1
3 Principle.....	1
4 Apparatus	2
4.1 IRHD pocket hardness meter	2
5 Test pieces	2
5.1 General	2
5.2 Thickness	3
5.3 Surface.....	3
6 Conditioning and test temperature.....	3
7 Procedure	3
7.1 General	3
7.2 Test time.....	3
7.3 Number of measurements.....	3
8 Calibration and checking.....	4
8.1 Calibration	4
8.2 Checking using standard rubber blocks.....	4
9 Test report.....	4
Bibliography.....	5

Foreword

ISO (the International Organization for Standardization) is a worldwide federation of national standards bodies (ISO member bodies). The work of preparing International Standards is normally carried out through ISO technical committees. Each member body interested in a subject for which a technical committee has been established has the right to be represented on that committee. International organizations, governmental and non-governmental, in liaison with ISO, also take part in the work. ISO collaborates closely with the International Electrotechnical Commission (IEC) on all matters of electrotechnical standardization.

International Standards are drafted in accordance with the rules given in the ISO/IEC Directives, Part 2.

The main task of technical committees is to prepare International Standards. Draft International Standards adopted by the technical committees are circulated to the member bodies for voting. Publication as an International Standard requires approval by at least 75 % of the member bodies casting a vote.

Attention is drawn to the possibility that some of the elements of this document may be the subject of patent rights. ISO shall not be held responsible for identifying any or all such patent rights.

ISO 7619-2 was prepared by Technical Committee ISO/TC 45, *Rubber and rubber products*, Subcommittee SC 2, *Testing and analysis*.

This second edition cancels and replaces the first edition (ISO 7619-2:2004), which has been technically revised to update the references to ISO 18898 for instrument calibration and ISO 23529 for the preparation of test pieces.

ISO 7619 consists of the following parts, under the general title *Rubber, vulcanized or thermoplastic — Determination of indentation hardness*:

- Part 1: *Durometer method (Shore hardness)*
- Part 2: *IRHD pocket meter method*

Introduction

The hardness of rubber, as measured by an IRHD pocket meter or a Shore durometer, is determined from the complex response of the rubber to an applied indentation. An IRHD pocket meter is a portable hand-held durometer calibrated to measure on the IRHD scale. The measurement will depend upon:

- a) the elastic modulus of the rubber;
- b) the viscoelastic properties of the rubber;
- c) the thickness of the test piece;
- d) the geometry of the indenter;
- e) the pressure exerted;
- f) the rate of increase of pressure;
- g) the interval after which the hardness is recorded.

Because of these factors, it is inadvisable to relate results obtained using an IRHD pocket meter directly to Shore durometer hardness values, although correlations have been established for some individual rubbers and compounds.

NOTE Further information on the relationship between the durometer values and IRHD values is given in the literature^{[3][4][5]}.

<https://standards.iteh.ai/catalog/standards/sist/9ffe4601-e1eb-4a68-9210-9997c96c3a03/iso-7619-2-2010>

iTeh STANDARD PREVIEW
(standards.iteh.ai)

ISO 7619-2:2010

<https://standards.iteh.ai/catalog/standards/sist/9ffe4601-e1eb-4a68-9210-9997c96c3a03/iso-7619-2-2010>

Rubber, vulcanized or thermoplastic — Determination of indentation hardness —

Part 2: IRHD pocket meter method

WARNING — Persons using this part of ISO 7619 should be familiar with normal laboratory practice. This part of ISO 7619 does not purport to address all of the safety problems, if any, associated with its use. It is the responsibility of the user to establish appropriate safety and health practices and to ensure compliance with any national regulatory conditions.

CAUTION — Certain procedures specified in this part of ISO 7619 may involve the use or generation of substances, or the generation of waste, that could constitute a local environmental hazard. Reference should be made to appropriate documentation on safe handling and disposal after use.

1 Scope

This part of ISO 7619 specifies a method for determining the indentation hardness of vulcanized or thermoplastic rubber by means of a pocket hardness meter calibrated in IRHD. The use of such meters is primarily intended for control, not specification, purposes (for specification, see ISO 48). It is possible to increase precision by fixing the pocket hardness meter on a support.

<https://standards.itih.ai/catalog/standards/sist/9ff4601-e1eb-4a68-9210-9997c96c3a03/iso-7619-2-2010>

2 Normative references

The following referenced documents are indispensable for the application of this document. For dated references only the edition cited applies. For undated references, the latest edition of the referenced document (including any amendments) applies.

ISO 48, *Rubber, vulcanized or thermoplastic — Determination of hardness (hardness between 10 IRHD and 100 IRHD)*

ISO 18898, *Rubber — Calibration and verification of hardness testers*

ISO 23529, *Rubber — General procedures for preparing and conditioning test pieces for physical test methods*

3 Principle

The measured property is the depth of penetration of a specified indenter forced into the material under specified conditions.

4 Apparatus

4.1 IRHD pocket hardness meter

4.1.1 Pressure foot

The pressure foot (see A in Figure 1) shall be square with sides $20\text{ mm} \pm 2,5\text{ mm}$ long or circular with a diameter of $22,5\text{ mm} \pm 2,5\text{ mm}$. It shall have a central hole of diameter $2,5\text{ mm} \pm 0,5\text{ mm}$ (see Figure 1).

Dimensions in millimetres

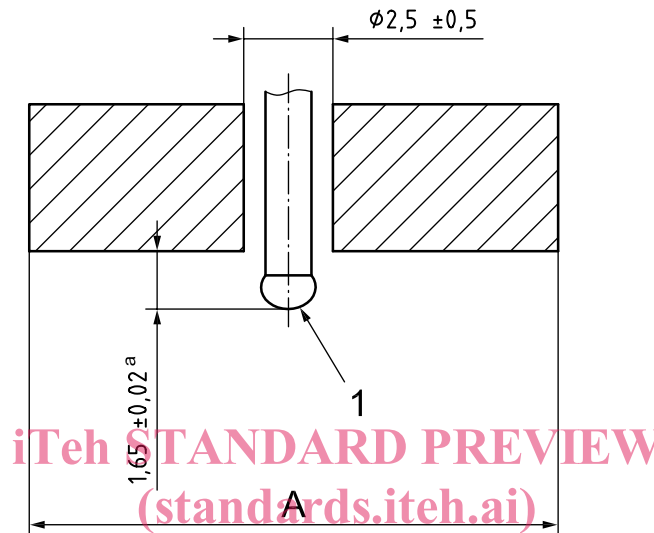

Key

1 hemispherical (diameter $1,575\text{ mm} \pm 0,025\text{ mm}$)

^a Valid at 30 IRHD.

ISO 7619-2:2010
<https://standards.iteh.ai/catalog/standards/sist/9ffe4601-e1eb-4a68-9210-9997c96c3a03/iso-7619-2-2010>

Figure 1 — Indenter for IRHD pocket meter

4.1.2 Indentor

The indentor end shall be hemispherical, with a diameter of $1,575\text{ mm} \pm 0,025\text{ mm}$ (see Figure 1).

4.1.3 Indicating device

This device allows the extent of protrusion of the indentor beyond the face of the pressure foot to be read. It shall be calibrated directly in terms of IRHD from the value 30 for the maximum protrusion of 1,65 mm to the value 100 for zero protrusion obtained by placing the pressure foot and indentor in firm contact with a flat and hard surface (e.g. glass).

4.1.4 Calibrated spring

This shall be used to apply a substantially constant force to the indentor of $2,65\text{ N} \pm 0,15\text{ N}$ over the 30 IRHD to 100 IRHD range.

5 Test pieces

5.1 General

Test pieces shall be prepared in accordance with ISO 23529.

5.2 Thickness

For the determination of hardness by pocket hardness meters, the thickness of the test piece shall be at least 6 mm.

For sheets thinner than 6 mm, the test piece may be composed of not more than three layers, none of which shall be thinner than 2 mm, in order to obtain the necessary thickness. However, determinations made on such test pieces might not agree with those made on single-thickness pieces.

For comparative-test purposes, the test pieces shall be similar.

5.3 Surface

The other dimensions of the test piece shall be sufficient to permit measurements at least 12 mm away from any edge. The surface of the test piece shall be flat over the area in contact with the pressure foot.

Satisfactory hardness determinations cannot be made on rounded, uneven or rough surfaces using pocket meters. However, their use in certain specialized applications is recognized, e.g. ISO 7267-1^[2] for the determination of the hardness of rubber-covered rolls. In such applications, the limitations to their use shall be clearly identified.

6 Conditioning and test temperature

Where practical, test pieces shall be conditioned immediately before testing for a minimum period of 1 h at one of the standard laboratory temperatures specified in ISO 23529. The same temperature shall be used throughout any single test or series of tests intended to be comparable.

7 Procedure

ISO 7619-2:2010
<https://standards.iteh.ai/catalog/standards/sist/9ff64601-e1eb-4a68-9210-9997c96c3a03/iso-7619-2-2010>

7.1 General

Place the test piece on a flat, hard, rigid surface (e.g. glass). Hold the hardness meter in position with the centre of the indenter at least 12 mm from the edges of the test piece. Apply the pressure foot to the test piece as rapidly as possible, without shock, keeping the foot parallel to the surface of the test piece and ensuring that the indenter is normal to the rubber surface.

7.2 Test time

Apply a force sufficient only to obtain firm contact between the pressure foot and the test piece and take the reading at the specified time after the pressure foot is in firm contact with the test piece. The standard test time is 3 s for vulcanized rubber and 15 s for thermoplastic rubber. Other test times may be used, provided they are stated in the test report. Rubbers of unknown types shall be treated as vulcanized.

NOTE A test time of 15 s has been introduced for thermoplastic rubber, as the hardness value continues to decrease over a longer period of time than for vulcanized rubber, this test time being the same as that specified for plastics in ISO 868^[1].

7.3 Number of measurements

Make five measurements of hardness at different positions on the test piece at least 6 mm apart and determine the median value.

If the time interval after which each reading was taken is different from 3 s, record the individual values of the indentation hardness together with the time interval after which each reading was taken, and determine the median value and the maximum and minimum values obtained.