



Designation: D 4745 – 06

# Standard Specification for Filled Compounds of Polytetrafluoroethylene (PTFE) Molding and Extrusion Materials<sup>1</sup>

This standard is issued under the fixed designation D 4745; the number immediately following the designation indicates the year of original adoption or, in the case of revision, the year of last revision. A number in parentheses indicates the year of last reapproval. A superscript epsilon ( $\epsilon$ ) indicates an editorial change since the last revision or reapproval.

## 1. Scope\*

1.1 This specification covers polytetrafluoroethylene (PTFE) filled molding compounds made with virgin PTFE resins defined in Specification D 4894, except Types I, IV, V, and VI.

NOTE 1—This specification can be used as a model for other PTFE compounds having particulate fillers that can survive the sintering temperatures of PTFE as can those listed in this specification. This specification is restricted to virgin PTFE base resin for technical reasons. Recycled or reprocessed material cannot be processed successfully.

NOTE 2—The properties measured on commercially fabricated parts may differ from the listed values for samples prepared by the procedures given in this specification, depending on part geometry and processing parameters.

NOTE 3—There is no ISO equivalent to this specification.

1.2 The values stated in SI units are to be regarded as standard.

1.3 The following statement applies to the test method portion, Section 12, of this specification: *This standard does not purport to address all of the safety concerns, if any, associated with its use. It is the responsibility of the user of this standard to establish appropriate safety and health practices and determine the applicability of regulatory limitations prior to use.* See 9.5 and Note 4 for a specific warning statement.

## 2. Referenced Documents

### 2.1 ASTM Standards:<sup>2</sup>

- D 618 Practice for Conditioning Plastics for Testing
- D 638 Test Method for Tensile Properties of Plastics
- D 792 Test Methods for Density and Specific Gravity (Relative Density) of Plastics by Displacement
- D 883 Terminology Relating to Plastics

<sup>1</sup> This specification is under the jurisdiction of ASTM Committee D20 on Plastics and is the direct responsibility of Subcommittee D20.15 on Thermoplastic Materials.

Current edition approved Dec. 1, 2006. Published December 2006. Originally approved in 1991. Last previous edition approved in 2001 as D 4745 - 01.

<sup>2</sup> For referenced ASTM standards, visit the ASTM website, www.astm.org, or contact ASTM Customer Service at service@astm.org. For *Annual Book of ASTM Standards* volume information, refer to the standard's Document Summary page on the ASTM website.

- D 1600 Terminology for Abbreviated Terms Relating to Plastics
- D 1895 Test Methods for Apparent Density, Bulk Factor, and Pourability of Plastic Materials
- D 3892 Practice for Packaging/Packing of Plastics
- D 4894 Specification for Polytetrafluoroethylene (PTFE) Granular Molding and Ram Extrusion Materials
- D 5740 Guide for Writing Material Standards in the Classification D 4000 Format
- E 11 Specification for Wire Cloth and Sieves for Testing Purposes
- E 691 Practice for Conducting an Interlaboratory Study to Determine the Precision of a Test Method
- IEEE/ASTM SI-10 Standard for Use of the International System of Units (SI): The Modern Metric System<sup>3</sup>

## 3. Terminology

3.1 *Definitions*—The terminology given in Terminology D 883 is applicable to this specification unless otherwise specified.

### 3.2 *Definitions of Terms Specific to This Standard:*

3.2.1 *bulk density, n*—the mass in kilograms per cubic metre of resin compound measured under the conditions of the test.

3.2.2 *filled compound, n*—blend of PTFE resin as the matrix and particulate fillers, generally glass, other inorganic, metallic, or polymeric materials that withstand the sintering temperature of PTFE (327 to 380°C).

3.2.3 *free-flow resins (pelletized), n*—generally made by treatment of finely divided resins to produce free-flowing agglomerates.

3.2.4 *lot, n*—one production run or a uniform blend of two or more production runs.

3.2.5 *pigmented compound, n*—a compound in which a pigment is added for colorant purposes only.

3.2.6 *standard flow resins (nonpelletized), n*—finely divided resin with an average particle size less than 100  $\mu\text{m}$ .

<sup>3</sup> Available from ASTM International Headquarters, 100 Barr Harbor Drive, West Conshohocken, PA 19428

\*A Summary of Changes section appears at the end of this standard.

**TABLE 1 TFE Compounds, Type I, Standard Flow (Nonpelletized)**

Grade	Raw Resin Bulk Density, min, g/L	Molded Parts (Molded and Sintered)					
		Specific Gravity, min	Specific Gravity, max	Tensile Strength		Elongation, min, %	
				min, MPa	min, psi		
1	15 % glass fiber	400	2.150	2.25	19.6	2840	250
2	25 % glass fiber	425	2.150	2.250	15.7	2270	200
3	35 % glass fiber	450	2.200	2.300	10.3	1500	150
4	5 % glass fiber and 5 % MoS <sub>2</sub>	350	2.150	2.300	20.7	3000	250
5	15 % glass fiber and 5 % MoS <sub>2</sub>	375	2.150	2.300	17.2	2500	200
6	10 % graphite	350	2.100	2.220	17.9	2600	225
7	15 % graphite	300	2.100	2.200	16.6	2400	100
8	25 % carbon and graphite	350	1.950	2.100	11.0	1600	80
9	32 % carbon and graphite	325	1.900	2.100	6.9	1000	50
10	40 % bronze	500	2.900	3.200	17.2	2500	175
11	60 % bronze	650	3.800	4.000	13.8	2000	140
12	55 % bronze and 5 % MoS <sub>2</sub>	700	3.500	4.000	10.3	1500	80
13	50 % stainless steel	500	3.200	3.600	17.2	2500	150

3.3 *Abbreviations*—Abbreviations are in accordance with Terminology **D 1600**. PTFE is the acronym for polytetrafluoroethylene.

#### 4. Classification

4.1 This specification covers the following two types of PTFE compounds:

4.1.1 *Type I*—Nonpelletized material, for general-purpose compression molding.

4.1.2 *Type II*—Pelletized or free-flowing material, for molding, automatic molding, or ram extrusion.

4.2 Thirteen grades of each type distinguished by the nature of the filler(s) are listed in **Tables 1-3**.

4.3 A one-line system may be used to specify materials covered by this specification. The system uses predefined cells to refer to specific aspects of this specification, as the following illustrates:

Standard Number Block	Specification			
	Type	Grade	Class	Special Notes
:	:	:	:	:
Example: Specification D 4745 – 97	II	2		

4.3.1 For this example, the line callout would be Specification D 4745 – 97, II 2, and would specify a pelletized or free-flowing filled composition of polytetrafluoroethylene that has all of the properties listed for that type, and grade in the appropriate specified properties, tables, or both, in the specification identified. A comma is used as the separator between the standard number and the type. Separators are not needed between the type, grade, and class.<sup>4</sup> A provision for special notes is included so that other information can be provided when required. An example would be in Specification D 3295 – 81a where dimensions and tolerances are specified for each AWG size within type and class. When special notes are used, they should be preceded by a comma.

<sup>4</sup> See the *ASTM Form and Style Manual*, available from ASTM Headquarters.

#### 5. Ordering Information

5.1 The filled compounds of PTFE may be ordered using the type, (see 4.1) and the grade (see reference **Table 1** and **Table 3**), or they may be ordered using the designation of the suppliers.

#### 6. Requirements

6.1 The PTFE compounds covered by this specification shall be uniform (filler and resin particles evenly distributed) and shall contain no foreign material.

6.2 The PTFE compounds shall conform to the requirements prescribed in **Tables 1-3** when tested by the procedures specified herein. **Table 1** and **Table 3** list requirements for Type I. **Table 2** and **Table 3** reference requirements for Type II.

6.3 Other PTFE compounds are commercially available, but are not described in this specification.

#### 7. Sampling

7.1 Sampling shall be statistically adequate to satisfy the requirements of **13.4**.

#### 8. Number of Tests

8.1 Routine lot inspection tests shall consist of those carried out to determine the requirements specified in **Table 1** or **Table 3** depending on type. Periodic tests shall include using all the tests to determine the requirements in **Table 3**, depending on type.

8.2 The requirements listed in **Tables 1-3**, as they apply, are sufficient to establish conformity of a material to this specification. When the number of test specimens is not stated in the test method, single determinations may be made. If more than single determinations are made on specimens from separate portions of the same sample, the results shall be averaged. The single or average result shall conform to the requirements prescribed in this specification.

#### 9. Test Specimens

9.1 Test specimens shall be cut from billets molded in accordance with the following procedures. An acceptable alternate procedure for molding the test plaque is described in Specification **D 4894**.

TABLE 2 TFE Compounds, Type II, Free-Flow (Pelletized)

Grade	Raw Resin Bulk Density, min, g/L	Molded Parts (Molded and Sintered)					
		Specific Gravity, min	Specific Gravity, max	Tensile Strength		Elongation, min, %	
				min, MPa	min, psi		
1	15 % glass fiber	625	2.150	2.25	13.8	2000	200
2	25 % glass fiber	625	2.150	2.250	12.4	1800	180
3	35 % glass fiber	650	2.200	2.300	8.3	1200	100
4	5 % glass fiber and 5 % MoS <sub>2</sub>	575	2.150	2.300	17.2	2500	220
5	15 % glass fiber and 5 % MoS <sub>2</sub>	600	2.150	2.300	13.8	2000	180
6	10 % graphite	600	2.100	2.220	13.8	2000	150
7	15 % graphite	550	2.100	2.200	10.3	1500	100
8	25 % carbon and graphite	500	1.950	2.100	8.3	1200	20
9	32 % carbon and graphite	500	1.900	2.100	6.9	1000	20
10	40 % bronze	750	2.900	3.200	13.8	2000	85
11	60 % bronze	900	3.800	4.000	10.3	1500	60
12	55 % bronze and 5 % MoS <sub>2</sub>	900	3.500	4.000	6.9	1000	60
13	50 % stainless steel	850	3.200	3.600	13.8	2000	100

TABLE 3 Required Filler Content

	Mass, %	Tolerance, ±, %
1	0 to 3	1
2	4 to 25	2
3	26 to 60	3
4	61 to 75	5

9.2 Test Billets:

9.2.1 Prior to molding, screen the material through a 2.0-mm hand sieve.

9.2.2 Preform solid test billets in a mold (see Fig. 1) having a cross-sectional area not greater than 25.8 cm<sup>2</sup> [4 in.<sup>2</sup>] and of sufficient height to contain the sample. Clearance should be sufficient to ensure escape of entrapped air during pressing. The billet length may be varied in accordance with the amount of testing to be done. A mold length of 250 mm [9.8 in.] produces a billet approximately 75 mm [2 to 3 in.] long. Powder-charge weight may be varied in accordance with the density of the material. The billet length should not exceed 75 mm [3 in.].

9.2.3 Assemble the mold. Add the resin to the mold, taking care not to fill within 13 mm [0.5 in.] of the top of the cavity. Insert the top plug and apply hand pressure, making certain that the pusher is centered in the mold. Place the mold in a hydraulic press and remove the support ring or spacers. Do not allow the two end plugs to bottom on the mold shell. Apply an initial load to the mold of 3.45 MPa [500 psi] ± 10 % and hold for 1 to 2 min. Increase the loading smoothly to the final preforming pressure in 3 to 5 min. Use 20.7 MPa [3000 psi] for compounds containing up to 4 % by weight filler. Use 34.5 MPa [5000 psi] for compounds containing 5 to 25 % by weight or less filler and 68.9 MPa [10 000 psi] for composite compounds containing more than 26 % filler. Hold under maximum pressure for 2 to 5 min. Release the pressure gradually without apparent movement of the press platens. Then open the press, remove the top pusher from the mold, and force the preform vertically out of the mold, using a continuous, smooth movement.

9.2.4 Place the preform in a sintering oven and sinter in accordance with the procedures in Table 4. Use Procedure B for compounds containing molybdenum disulfide filler.

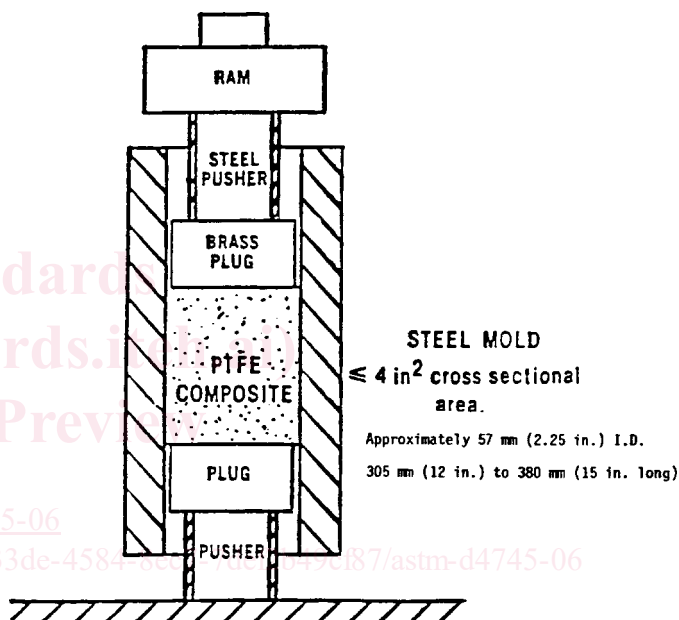

FIG. 1 Preforming of PTFE Composite Test Billet

TABLE 4 Sintering Procedures for Test Billets

	Procedure A	Procedure B
Initial temperature, °C (±) <sup>A</sup>	Ambient	Ambient
Rate of heating, °C/h [°F/h]	60 ± 5 [108 ± 9]	60 ± 5 [108 ± 10]
Hold temperature, °C [°F]	370 ± 6 [698 ± 10]	360 ± 6 [680 ± 10]
Hold time, min	240 ± 5	240 ± 5
Rate of cooling, °C/h [°F/h]	60 ± 5 [108 ± 9]	60 ± 5 [108 ± 9]
Final temperature, °C [°F] <sup>A</sup>	95 ± 6 [203 ± 10]	95 ± 6 [203 ± 10]
Time to cool to room temperature, h	24	24

<sup>A</sup> Oven can be opened safely at these temperatures.

9.3 Sectioning Test Billet:

9.3.1 Remove and discard the top and bottom 2-mm [1/16 in.] section of the billet. Obtain transverse test specimens from as near the center of the billet as possible.

9.3.2 Prepare five test specimens, 1 ± 0.25 mm [0.040 ± 0.010 in.] in thickness for the determination of tensile strength and elongation and cut a piece of suitable thickness for density measurements. This piece should be approximately cubical in