**Tractors for agriculture and forestry —
Safety —**

**Part 2:
Narrow-track and small tractors**

Tracteurs agricoles et forestiers — Sécurité —

Partie 2: Tracteurs à voie étroite et tracteurs compacts

iTeh STANDARD PREVIEW
(standards.iteh.ai)

ISO 26322-2:2010

<https://standards.iteh.ai/catalog/standards/sist/9ef46c2c-4daf-4cdf-8a02-f00c47ff975e/iso-26322-2-2010>



PDF disclaimer

This PDF file may contain embedded typefaces. In accordance with Adobe's licensing policy, this file may be printed or viewed but shall not be edited unless the typefaces which are embedded are licensed to and installed on the computer performing the editing. In downloading this file, parties accept therein the responsibility of not infringing Adobe's licensing policy. The ISO Central Secretariat accepts no liability in this area.

Adobe is a trademark of Adobe Systems Incorporated.

Details of the software products used to create this PDF file can be found in the General Info relative to the file; the PDF-creation parameters were optimized for printing. Every care has been taken to ensure that the file is suitable for use by ISO member bodies. In the unlikely event that a problem relating to it is found, please inform the Central Secretariat at the address given below.

iTeh STANDARD PREVIEW
(standards.iteh.ai)

ISO 26322-2:2010

<https://standards.iteh.ai/catalog/standards/sist/9ef46c2c-4daf-4cdf-8a02-f00c47ff975e/iso-26322-2-2010>



COPYRIGHT PROTECTED DOCUMENT

© ISO 2010

All rights reserved. Unless otherwise specified, no part of this publication may be reproduced or utilized in any form or by any means, electronic or mechanical, including photocopying and microfilm, without permission in writing from either ISO at the address below or ISO's member body in the country of the requester.

ISO copyright office
Case postale 56 • CH-1211 Geneva 20
Tel. + 41 22 749 01 11
Fax + 41 22 749 09 47
E-mail copyright@iso.org
Web www.iso.org

Published in Switzerland

Foreword

ISO (the International Organization for Standardization) is a worldwide federation of national standards bodies (ISO member bodies). The work of preparing International Standards is normally carried out through ISO technical committees. Each member body interested in a subject for which a technical committee has been established has the right to be represented on that committee. International organizations, governmental and non-governmental, in liaison with ISO, also take part in the work. ISO collaborates closely with the International Electrotechnical Commission (IEC) on all matters of electrotechnical standardization.

International Standards are drafted in accordance with the rules given in the ISO/IEC Directives, Part 2.

The main task of technical committees is to prepare International Standards. Draft International Standards adopted by the technical committees are circulated to the member bodies for voting. Publication as an International Standard requires approval by at least 75 % of the member bodies casting a vote.

Attention is drawn to the possibility that some of the elements of this document may be the subject of patent rights. ISO shall not be held responsible for identifying any or all such patent rights.

ISO 26322-2 was prepared by Technical Committee ISO/TC 23, *Tractors and machinery for agriculture and forestry*, Subcommittee SC 4, *Tractors*.

This first edition of ISO 26322-2, together with ISO 26322-1, cancels and replaces ISO 4254-3:1992, of which it constitutes a technical revision. It also incorporates requirements for tractor safety formerly given in ISO 4254-1. Additional requirements have been included in order to take account of the technical evolution of the tractors and changes in their use that have occurred since publication of the replaced International Standard.

<https://standards.iteh.ai/catalog/standards/sist/9ef46c2c-4daf-4cdf-8a02-f0c47ff975e/iso-26322-2-2010>

ISO 26322 consists of the following parts, under the general title *Tractors for agriculture and forestry — Safety*:

- *Part 1: Standard tractors*
- *Part 2: Narrow-track and small tractors*

iTeh STANDARD PREVIEW
(standards.iteh.ai)

ISO 26322-2:2010

<https://standards.iteh.ai/catalog/standards/sist/9ef46c2c-4daf-4cdf-8a02-f00c47ff975e/iso-26322-2-2010>

Tractors for agriculture and forestry — Safety —

Part 2: Narrow-track and small tractors

1 Scope

This part of ISO 26322 specifies the general safety requirements and their verification for the design and construction of narrow-track and small tractors used in agriculture and forestry. It also specifies the type of information on safe working practices, including residual risks, to be provided by the manufacturer. It provides technical means for improving the level of personal safety of operators and others involved in the course of the normal operation, maintenance and use of these tractors.

It is applicable to narrow-track tractors having at least two axles for pneumatic-tired wheels, or having tracks instead of wheels with a smallest fixed or adjustable track width of not more than 1 150 mm, and to small tractors having an unladen mass not greater than 600 kg.

NOTE Tractors having a smallest fixed or adjustable track width greater than 1 150 mm and an unladen mass greater than 600 kg are dealt with in ISO 26322-1.

It is not applicable to vibration or braking. [ISO 26322-2:2010](https://standards.iteh.ai/catalog/standards/sist/9ef46c2c-4daf-4cdf-8a02-f00c47ff975e/iso-26322-2-2010)

<https://standards.iteh.ai/catalog/standards/sist/9ef46c2c-4daf-4cdf-8a02-f00c47ff975e/iso-26322-2-2010>

2 Normative references

The following referenced documents are indispensable for the application of this document. For dated references, only the edition cited applies. For undated references, the latest edition of the referenced document (including any amendments) applies.

ISO 500-1, *Agricultural tractors — Rear-mounted power take-off types 1, 2 and 3 — Part 1: General specifications, safety requirements, dimensions for master shield and clearance zone*

ISO 500-2, *Agricultural tractors — Rear-mounted power take-off types 1, 2 and 3 — Part 2: Narrow-track tractors, dimensions for master shield and clearance zone*

ISO 3776-1, *Tractors and machinery for agriculture — Seat belts — Part 1: Anchorage location requirements*

ISO 3776-2, *Tractors and machinery for agriculture — Seat belts — Part 2: Anchorage strength requirements*

ISO 3776-3, *Tractors and machinery for agriculture — Seat belts — Part 3: Requirements for assemblies*

ISO 4252, *Agricultural tractors — Operator's workplace, access and exit — Dimensions*

ISO 5353, *Earth-moving machinery, and tractors and machinery for agriculture and forestry — Seat index point*

ISO 8759-1, *Agricultural wheeled tractors — Front-mounted equipment — Part 1: Power take-off and three-point linkage*

ISO 12003-1, *Agricultural and forestry tractors — Roll-over protective structures on narrow-track wheeled tractors — Part 1: Front-mounted ROPS*

ISO 12003-2, *Agricultural and forestry tractors — Roll-over protective structures on narrow-track wheeled tractors — Part 2: Rear-mounted ROPS*

ISO 23205:2006, *Agricultural tractors — Instructional seat*

ISO 26322-1:2008, *Tractors for agriculture and forestry — Safety requirements — Part 1: Standard tractors*

3 Terms and definitions

For the purposes of this document, the terms and definitions given in ISO 26322-1 and the following apply.

3.1

narrow-track tractor

agricultural or forestry tractor having an unladen mass greater than 600 kg and a fixed or adjustable minimum track width of the axle fitted with the larger tyres of not more than 1 150 mm, it being possible to set the track width of the axle fitted with the smaller tyres so that the overall width across those tyres is not greater than the overall width across the larger tyres, and on which, if both axles are fitted with tyres of the same size, the fixed or adjustable track width of both axles is not greater than 1 150 mm

3.2

small tractor

agricultural or forestry tractor having an unladen mass not greater than 600 kg

ITeh STANDARD PREVIEW
(standards.iteh.ai)

4 Safety requirements

ISO 26322-2:2010

4.1 Fundamental principles and design guidance

<https://standards.iteh.ai/catalog/standards/sist/9ef46c2c-4daf-4cdf-8a02-100c771b75c/iso-26322-2-2010>

The fundamental principles and design guidance given in ISO 26322-1:2008, 4.1, apply.¹⁾

4.2 Noise

For noise, the provisions of ISO 26322-1:2008, 4.2, apply.

4.3 Controls

For controls, the provisions of ISO 26322-1:2008, 4.3, apply.

4.4 Operator station

4.4.1 Boarding means

4.4.1.1 General

The provisions of ISO 26322-1:2008, 4.4.1.1, apply.

1) This includes reference to ISO 12100-1:2003, Clause 5, since replaced by ISO 12100:2010, *Safety of machinery — General principles for design — Risk assessment and risk reduction*, Clauses 4 and 5.

4.4.1.2 Steps and ladders

For steps and ladders, the provisions of ISO 26322-1:2008, 4.4.1.2, apply.

4.4.1.3 Handrails/handholds

For handrails/handholds, the provisions of ISO 26322-1:2008, 4.4.1.3, apply.

4.4.2 Operator's workplace

4.4.2.1 The operator's workplace, access and exit dimensions shall be in accordance with ISO 4252, except for Table 1, whose values shall be replaced by the values given in Table 1 below.

Table 1 — Minimum internal clearance dimensions

Distance	Minimum dimension mm
Distance from a point 90 mm below and $(140 + a_h)$ mm behind the seat index point (SIP) to any part of the cab ceiling surface, above, forward and to either side of the operator's head ^a	940 ^c
Distance from the SIP to the cabin back wall at a height between 210 mm above the SIP and the roof contour defined by the 910 mm radius and the 150 mm blend radius	$260 + a_h$
Lateral clearance at any distance between 310 mm above the SIP and the roof contour defined by the 910 mm radius, perpendicular to the vertical reference plane for a distance of $(310 + a_h)$ mm forward and $(140 + a_h)$ mm rearward from the SIP	350
Distance from the outer side of the steering-wheel rim to the cabin surface or other hand controls ^b	50
<p>^a Soft materials such as padding may penetrate into the free space up to a maximum of 50 mm.</p> <p>^b Excluding hand controls mounted on the steering column.</p> <p>^c It is intended that, at the next revision of this part of ISO 26322, this value be further evaluated, taking into consideration the development of the physical dimensions of operators and the operating environment of these tractors.</p>	

4.4.2.2 There shall be no shearing or crushing points within hand or foot reach of the operator when seated in the seat provided.

4.4.2.3 The foot reach of the operator is defined by a hemisphere of 800 mm radius centred on the seat centreline at the front edge of the cushion and extending downwards, with the seat in its central position.

The hand reach of the operator is divided into spherical volumes A and B, as shown in Figure 1. The spherical centre point of the volumes is located 60 mm in front and 580 mm above the SIP, as defined in ISO 5353 and indicated in Figure 1. Volume A is formed by a spherical radius of 550 mm, volume B is the volume between this radius and a spherical radius of 1 000 mm.

Within volume A, a minimum clearance of 120 mm between power and inertia-operated, and other adjacent parts, shall be maintained. Within volume B, a minimum clearance of 25 mm shall be maintained. Within both volumes, a minimum angle of 30° shall be maintained where parts shear against each other.

The hand and foot reach for tractors equipped with a cabin is limited to those portions of the volumes specified, lying within the cab.

These requirements do not apply to any points behind a plane located at an angle of 45° to the rear and running transverse to the travel direction through a point located 230 mm behind the SIP (see Figure 1).

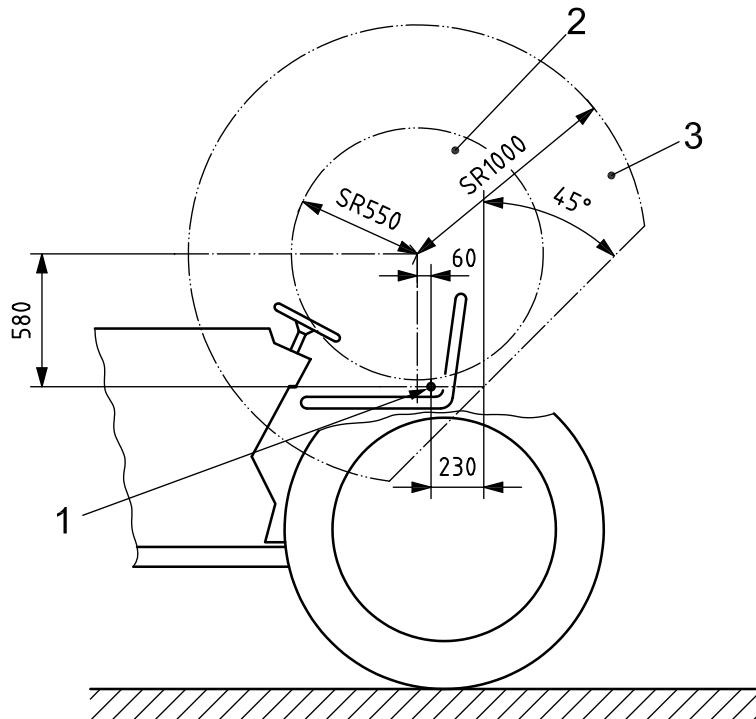

iTeh STANDARD PREVIEW
(standards.iteh.ai)

ISO 26322-2:2010

<https://standards.iteh.ai/catalog/standards/sist/9ef46c2c-4daf-4cdf-8a02-100e-272727272727>

Figure 100e Operator's hand reach

Key

- 1 SIP
- 2 volume A
- 3 volume B

4.4.3 Operator's seat

A seat shall be provided which will adequately support the operator in all working and operating modes. Information on the seat adjustment shall be provided in the operator's manual. Additionally, two-point seat belts (lap belts) in accordance with ISO 3776-1, ISO 3776-2 and ISO 3776-3 shall be provided on narrow-track tractors.

4.4.4 Instructional seat

An instructional seat, if installed, shall be in accordance with ISO 23205. The exception to this is the case of small tractors without ROPS (roll-over protective structures), for which ISO 23205:2006, 4.7, does not apply.

4.4.5 Cab material burning rate

For the cab material burning rate, the provisions of ISO 26322-1:2008, 4.4.5, apply.

4.5 Power take-off (PTO)

Rear-mounted PTOs shall be in accordance with ISO 500-1 or ISO 500-2, as declared by the manufacturer. Front-mounted PTOs shall be in accordance with ISO 8759-1. Additionally, any components of the tractor that transmit power to the PTO, that are not addressed in ISO 500-1, ISO 500-2 or ISO 8759-1, shall be guarded by location (see ISO 26322-1:2008, 4.1.2), safety distances or with guard(s).

4.6 Strength requirements for guards and barriers

For the strength of guards and barriers, the provisions of ISO 26322-1:2008, 4.6, apply.

4.7 Electrical equipment

For electrical equipment, the provisions of ISO 26322-1:2008, 4.7, apply.

4.8 Hydraulic components and fittings

For hydraulic components and fittings, the provisions of ISO 26322-1:2008, 4.8, apply.

4.9 Ballast weights

For ballast weights, the provisions of ISO 26322-1:2008, 4.9, apply.

4.10 Levelling adjustments — Rear and front linkages

For levelling adjustments of rear and front linkages, the provisions of ISO 26322-1:2008, 4.10, apply.

4.11 Fuel systems

For the fuel system, the provisions of ISO 26322-1:2008, 4.11, apply.

4.12 Roll-over protection

iTeh STANDARD PREVIEW
(standards.iteh.ai)

4.12.1 A roll-over protection system meeting the requirements of either ISO 12003-1 or ISO 12003-2 shall be installed on each tractor having an unladen mass greater than 600 kg.

<https://standards.iteh.ai/catalog/standards/sist/9ef46c2c-4daf-4cdf-8a02->

4.12.2 In addition, the provisions of ISO 26322-1, 4.12.2, apply.

4.13 Falling objects protection

For falling objects protection, the provisions of ISO 26322-1, 4.13, apply.

4.14 Hot surfaces

For hot surfaces, the provisions of ISO 26322-1:2008, 4.14, apply.

4.15 Exhaust gases

For exhaust gases, the provisions of ISO 26322-1:2008, 4.15, apply.

5 Information for use

5.1 Operator's manual

For the operator's manual, the provisions of ISO 26322-1:2008, 5.1, apply.

5.2 Safety and instructional signs

For safety and instructional signs, the provisions of ISO 26322-1:2008, 5.2, apply.