International Standard



787/18

INTERNATIONAL ORGANIZATION FOR STANDARDIZATION • МЕЖДУНАРОДНАЯ ОРГАНИЗАЦИЯ ПО СТАНДАРТИЗАЦИИ • ORGANISATION INTERNATIONALE DE NORMALISATION

**General methods of test for pigments and extenders —
Part 18 : Determination of residue on sieve —
Mechanical flushing procedure**

Méthodes générales d'essai des pigments et matières de charge — Partie 18 : Détermination du refus sur tamis — Méthode mécanique avec liquide d'entraînement

ITh STANDARD PREVIEW

Second edition — 1983-02-15 (standards.iteh.ai)

[ISO 787-18:1983](#)

<https://standards.iteh.ai/catalog/standards/sist/b28328ec-744c-4bf3-9613-2e1293f53b19/iso-787-18-1983>

UDC 667.622 : 620.1 : 621.928

Ref. No. ISO 787/18-1983 (E)

Descriptors : paints, pigments, determination, sieve residues.

Price based on 4 pages

Foreword

ISO (the International Organization for Standardization) is a worldwide federation of national standards bodies (ISO member bodies). The work of developing International Standards is carried out through ISO technical committees. Every member body interested in a subject for which a technical committee has been authorized has the right to be represented on that committee. International organizations, governmental and non-governmental, in liaison with ISO, also take part in the work.

Draft International Standards adopted by the technical committees are circulated to the member bodies for approval before their acceptance as International Standards by the ISO Council.

International Standard ISO 787/18 was developed by Technical Committee ISO/TC 35, *Paints and varnishes*, and was circulated to the member bodies in November 1980.

It has been approved by the member bodies of the following countries:

Austria	Ireland	Poland
Belgium	Israel	Portugal
Brazil	Italy	Romania
Canada	Kenya	South Africa, Rep. of
China	Korea, Dem. P. Rep. of	Spain
Czechoslovakia	Korea, Rep. of	Sweden
Egypt, Arab Rep. of	Mexico	Switzerland
Germany, F. R.	Netherlands	United Kingdom
Hungary	Norway	USSR

The member body of the following country expressed disapproval of the document on technical grounds :

France

This International Standard cancels and replaces ISO 787/XVIII-1973, of which it constitutes a technical revision.

The purpose of this International Standard is to establish a series of general test methods for pigments and extenders which are suitable for all or many of the individual pigments and extenders for which specifications might be required. In such cases, a cross-reference to the general method should be included in the International Standard relating to that pigment or extender, with a note of any detailed modifications which might be needed in view of the special properties of the product in question.

Technical Committee ISO/TC 35, *Paints and varnishes*, decided that all the general methods should be published as they become available, as parts of a single International Standard, in order to emphasize the relationship of each to the whole series.

The Technical Committee also decided that, where two or more procedures were widely used for determining the same or a similar characteristic of a pigment or extender, there would be no objection to including more than one of them in the ISO series. In such cases it will, however, be essential to state clearly in a specification which method is to be used and in the test report, which method has been used.

Parts of the series already published are as follows :

<https://standards.iteh.ai/catalog/standards/sist/b28328ec-744c-4bf3-9613-209353100000/iso-787-16-1986>

- Part 1 : Comparison of colour of pigments
- Part 2 : Determination of matter volatile at 105 °C
- Part 3 : Determination of matter soluble in water — Hot extraction method
- Part 4 : Determination of acidity or alkalinity of the aqueous extract
- Part 5 : Determination of oil absorption value
- Part 7 : Determination of residue on sieve — Water method — Manual procedure
- Part 8 : Determination of matter soluble in water — Cold extraction method
- Part 9 : Determination of pH value of an aqueous suspension
- Part 10 : Determination of density — Pyknometer method
- Part 11 : Determination of tamped volume and apparent density after tamping
- Part 13 : Determination of water-soluble sulphates, chlorides and nitrates
- Part 14 : Determination of resistivity of aqueous extract
- Part 15 : Comparison of resistance to light of coloured pigments of similar types
- Part 16 : Comparison of relative tinting strength (or equivalent colouring value) and colour on reduction in linseed stand oil using the automatic muller
- Part 17 : Comparison of lightening power of white pigments
- Part 18 : Determination of residue on sieve — Mechanical flushing procedure
- Part 19 : Determination of water-soluble nitrates — Salicylic acid method
- Part 20 : Comparison of ease of dispersion — Oscillatory shaking method
- Part 21 : Comparison of heat stability of pigments using a stoving medium
- Part 22 : Comparison of resistance to bleeding of pigments
- Part 23 : Determination of density (using a centrifuge to remove entrained air)
- Part 24 : Determination of relative tinting strength of coloured pigments and relative scattering power of white pigments — Photometric method

iTeh STANDARD PREVIEW

This page intentionally left blank
(standards.iteh.ai)

ISO 787-18:1983

<https://standards.iteh.ai/catalog/standards/sist/b28328ec-744c-4bf3-9613-2e1293f53b19/iso-787-18-1983>

General methods of test for pigments and extenders — Part 18 : Determination of residue on sieve — Mechanical flushing procedure

0 Introduction

This document is a part of ISO 787, *General methods of test for pigments and extenders*.

1 Scope and field of application

1.1 This part of ISO 787 specifies a general method for determining the residue on a sieve from a sample of pigment or extender dispersed in water, using a mechanical flushing procedure. This method can also be applied to the examination of other powders or granules which are insoluble in water. It is neither applicable to hydrophobic nor pelletized pigments and extenders.

1.2 ISO 787/7 specifies a general method of test for determining the residue on a sieve from a sample of pigment or extender dispersed in water, using a manual procedure.

1.3 For most pigments and extenders, these two test methods will give different results, and it is therefore essential to state clearly in a specification which method is to be used, and in the test report, which method has been used.

NOTE — When either of these general methods is applicable to a given pigment or extender, only a cross-reference to it should be included in the International Standard relating to that pigment or extender, with a note of any detailed modification which may be needed in view of the special properties of the material under consideration. Only when neither of these general methods is applicable to a particular material a special method for determination of residue on sieve should be specified.

2 References

ISO 565, *Test sieves — Woven metal wire cloth, perforated plate and electroformed sheet — Nominal sizes of openings*.

ISO 787/7, *General methods of test for pigments and extenders — Part 7 : Determination of residue on sieve — Water method — Manual procedure*.

ISO 842, *Raw materials for paints and varnishes — Sampling*.

3 Definition

residue on sieve (R) : The coarse particles which remain on a sieve of a specified nominal aperture when a test is performed in accordance with this International Standard.

4 Principle

In the test apparatus, the pigment or extender under test, dispersed in water, is brought into centrifugal motion by a system of rotating jets of water. The water flushes the fine particles through the sieve, the coarse particles being retained on the sieve. The residue on the sieve is dried and weighed.

5 Materials

5.1 **Filtered tap water**, at a pressure of 300 ± 20 kPa above atmospheric.

5.2 **Wetting agents**, such as ethanol 95 % (V/V) or sulphonates, etc., for pigments and extenders that are difficult to wet with water. The selection of an appropriate wetting agent shall be agreed between the parties, and the wetting agent used shall be stated in the test report.

6 Apparatus

Ordinary laboratory apparatus and

6.1 **Mechanical flushing apparatus** (see the figure) consisting of the following items.

6.1.1 **Container**.

6.1.2 **Cover**, with protective hood, driving motor, hollow shaft with two nozzles with an internal diameter of $1 \pm 0,2$ mm, head with three nozzles of diameter $1 \pm 0,2$ mm, water supply connection, filling funnel, handle and overflow.

NOTE — With the specified pressure and internal diameter of the nozzles the water flow will be about 5 l/min. It is recommended that

the internal diameter of the nozzles should be periodically examined. Calcareous deposits should be dissolved by chemical substances which do not attack the material of the nozzles. The cleaning should not be performed by mechanical means.

6.1.3 Sieve, consisting of a frame of metal or plastics material with a wire gauze of phosphor-bronze or stainless steel.

The nominal mesh aperture shall be selected from the principal sizes specified in ISO 565 and shall be stated in the test report.

NOTES

- 1 Sieves may also be used in which three breaker lugs for dispersal of agglomerates project into the plane of the sieve.
- 2 Sieves of nominal mesh aperture of 45 µm are frequently used. It is recommended that the mesh apertures of the sieve should be periodically examined to check whether the mesh aperture of the sieve has been damaged, for example by the water jet or by heat. The sieve should be discarded if the mesh apertures have been affected.
- 3 If a sieve with a plastics frame is used, care should be taken that the softening point of the plastics material is well above the temperature used for drying the residue. Sieves with a plastics frame should be heated at 105 °C to constant mass before being used for the first time.

6.1.4 Sieve holder.

6.2 Oven, capable of being maintained at 105 ± 2 °C.

6.3 Balance, accurate to at least 0,1 mg.

6.4 Desiccator, containing an efficient desiccant.

7 Sampling

Take a representative sample of the material to be tested as described in ISO 842.

8 Procedure

Carry out the determination in duplicate.

8.1 Test portion

Weigh, to the nearest 0,1 %, into a beaker of suitable capacity, a quantity of the sample, m_0 , such that a sufficient residue on the sieve (6.1.3) is obtained. Generally, a test portion of 5 to 50 g is necessary, but in the case of products yielding a very low residue on the sieve a greater test portion, up to 300 g, should be used.

8.2 Preparation of the dispersion

Disperse the test portion (8.1) in a suitable quantity of water in a beaker by stirring with a glass rod to give a free-flowing

suspension. If the test portion is not readily wetted by water, use a wetting agent (5.2).

NOTE — A slowly rotating paddle stirrer may be used, but do not use high power stirrers as these may cause the de-aggregation of pigment particles.

8.3 Determination

8.3.1 Adjust the flow of the water of the mechanical flushing apparatus (6.1) so that the water pressure is 300 ± 20 kPa above atmospheric, and switch on the motor. Transfer the suspension quantitatively, by way of the funnel (see the figure), to the apparatus and rinse the beaker and funnel with water. Record the time when the fine particles have almost completely passed through the sieve as indicated by the noise of the water passing through the nozzles becoming louder, hissing sharply and then remaining constant, while at the same time the water running through the sieve appears to be clear.

Continue flushing for a further 10 min (see note 1) in order to break agglomerates by the now fully active water jet and to rinse the last fine particles through the sieve (see note 2).

NOTES

- 1 For some pigments a flushing duration of 10 min is not necessary. With such pigments the required duration should be determined by preliminary experiments and if a period shorter than 10 min is used this should be stated in the test report.
- 2 If the flushing water is very hard, it is advisable to give the apparatus a final rinse with distilled water in order to prevent the formation of deposits of calcium salts on the sieve on drying.

8.3.2 Switch off the motor, and then stop the water flow. Remove the sieve from the test apparatus and dry it in the oven (6.2) at 105 ± 2 °C (see the note) for 1 h. Allow the sieve and residue to cool in the desiccator (6.4) and weigh to the nearest 0,1 mg (m_1). Remove the residue from the sieve using a fine brush and weigh the empty sieve to the nearest 0,1 mg (m_2).

NOTE — If the melting point of the residue on the sieve is lower than 110 °C, a more suitable drying temperature should be used and this should be stated in the test report.

8.3.3 If the duplicate determinations differ by more than 0,1 % absolute, repeat the procedure. If the two further determinations still differ by more than 0,1 % absolute, state all four values in the test report, and check the product for in-homogeneity.

8.4 Examination of the residue

Inspect the residue for the presence of incompletely dispersed pigment or extender and, if present, repeat the whole procedure (clause 8) using an alternative dispersing agent agreed between the parties.

If the residue contains extraneous matter, report its presence and nature.

iTeh STANDARD PREVIEW
 (standard not for sale)
<https://standards.iteh.ai/catalog/standards/sist/88403238-7402-4012-9012-2e1293f53b19/iso-787-18-1983>

9 Expression of results

Calculate the residue on sieve (mechanical flushing procedure) by the equation

$$R = \frac{(m_1 - m_2)}{m_0} \times 100$$

where

R is the residue on sieve, expressed as a percentage by mass;

m_0 is the mass, in grams, of the test portion;

m_1 is the mass, in grams, of the sieve with residue;

m_2 is the mass, in grams, of the empty sieve.

Report the mean of the duplicate determinations if they agree to within 0,1 % absolute. If not, see 8.3.3. If the result with the 100 g test portion is less than 0,01 % this should be stated in the test report as "less than 0,01 %".

10 Test report

The test report shall contain at least the following information :

- a) the type and identification of the product tested;
- b) a reference to this International Standard (ISO 787/18);
- c) the result of the test as indicated in clause 9;
- d) the nominal mesh aperture of the sieve used;
- e) the mass of the test portion;
- f) if used, the type and quantity of the wetting agent;
- g) a description of the type and condition of the residue on sieve (for example extraneous matter);
- h) any deviation, by agreement or otherwise, from the procedure specified (see note 1 to 6.1.3, note 1 to 8.3.1 and note to 8.3.2);
- j) the date of the test.

iTeh STANDARD PREVIEW (standards.iteh.ai)

[ISO 787-18:1983](https://standards.iteh.ai/catalog/standards/sist/b28328ec-744c-4bf3-9613-2e1293f53b19/iso-787-18-1983)

<https://standards.iteh.ai/catalog/standards/sist/b28328ec-744c-4bf3-9613-2e1293f53b19/iso-787-18-1983>

Dimensions in millimetres

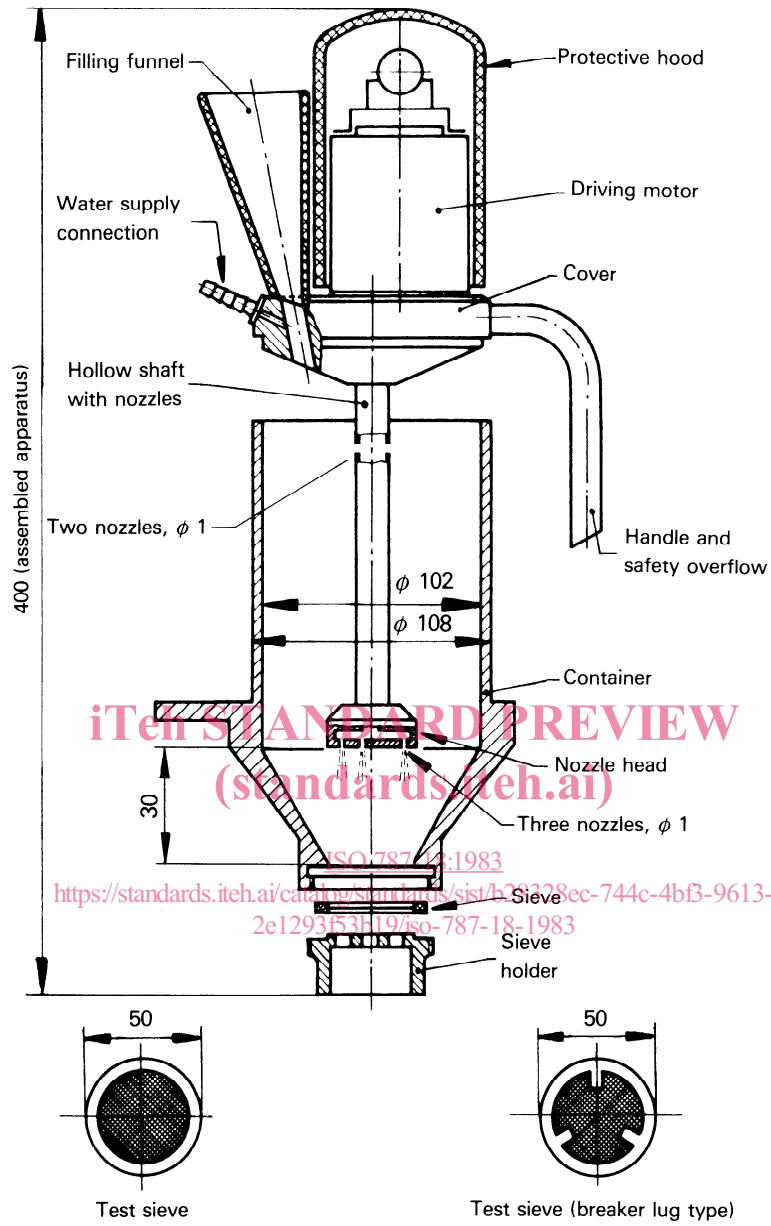

Figure — Mechanical flushing apparatus