



Designation: E672 – 87 (Reapproved 2006)

Standard Specification for Disposable Glass Micropipets¹

This standard is issued under the fixed designation E672; the number immediately following the designation indicates the year of original adoption or, in the case of revision, the year of last revision. A number in parentheses indicates the year of last reapproval. A superscript epsilon (ϵ) indicates an editorial change since the last revision or reapproval.

This standard has been approved for use by agencies of the Department of Defense.

1. Scope

1.1 This specification covers two different types of disposable micropipets, calibrated “to contain,” used in measuring microlitre volumes of liquids.

1.2 The values stated in SI units are to be regarded as the standard.

1.3 The following precautionary caveat pertains only to paragraph 9.1.1 of this specification. *This standard does not purport to address all of the safety concerns, if any, associated with its use. It is the responsibility of the user of this standard to establish appropriate safety and health practices and determine the applicability of regulatory limitations prior to use.*

2. Referenced Documents

2.1 ASTM Standards:²

E438 Specification for Glasses in Laboratory Apparatus

2.2 ISO Standard:³

R-1769 Color Coding for Pipets

3. Terminology

3.1 *Definitions of Terms Specific to This Standard:*

3.1.1 *accuracy*—the closeness of agreement between the nominal value and the mean volume, obtained by applying the test procedure specified in 9.4.1. It is quantified by the inaccuracy of the mean (bias).

3.1.2 *disposable micropipet*—such micropipets will only be expected to provide their specified performance during their original use or operation.

NOTE 1—The descriptions of “accuracy” and “repeatability” apply only in cases where the distributions are Gaussian.

3.1.3 *repeatability*—the closeness of agreement between the individual volumes obtained by applying the test procedure specified in 9.4.2. It is quantified by the imprecision.

4. Classification

4.1 This specification covers two different pipet designs as follows:

4.1.1 *Type I*—Disposable micropipets with calibration line and color coding (see Fig. 1 and Table 1).

4.1.2 *Type II*—Disposable micropipets void of markings (see Fig. 2 and Table 2).

NOTE 2—Type I pipets were originally specified by the Department of Defense under MIL-P-36722.

5. Materials and Manufacture

5.1 The pipets made to these specifications shall be fabricated from borosilicate glass, Type I, Class A or B or soda lime glass, Type II, in accordance with Specification E438.

6. Dimensions and Permissible Variations

6.1 *Design*—Pipets shall be of one piece construction in accordance with Table 1 and Table 2 for shape, dimensions, and permissible variations. Any cross-section of the pipet, taken in a plane perpendicular to the longitudinal axis, shall be circular.

6.2 *Capacity*—The pipet capacity shall be stated on the package label, expressed as μL (microlitre); this shall be known as the stated capacity, V_1 , in making subsequent calculations. The expected deviation from the stated capacity shall be expressed as accuracy and coefficient of variation and shall be tested for capacity as specified in 9.1. The unit, microlitre, μL , may be considered as equivalent to 0.001 cm^3 .

¹ This specification is under the jurisdiction of ASTM Committee E41 on Laboratory Apparatus and is the direct responsibility of Subcommittee E41.01 on Apparatus.

Current edition approved Nov. 1, 2006. Published December 2006. Originally approved in 1978. Last previous edition approved in 2001 as E672 – 87 (2001) ^{ϵ} . DOI: 10.1520/E0672-87R06.

² For referenced ASTM standards, visit the ASTM website, www.astm.org, or contact ASTM Customer Service at service@astm.org. For Annual Book of ASTM Standards volume information, refer to the standard’s Document Summary page on the ASTM website.

³ Available from American National Standards Institute (ANSI), 25 W. 43rd St., 4th Floor, New York, NY 10036, http://www.ansi.org.

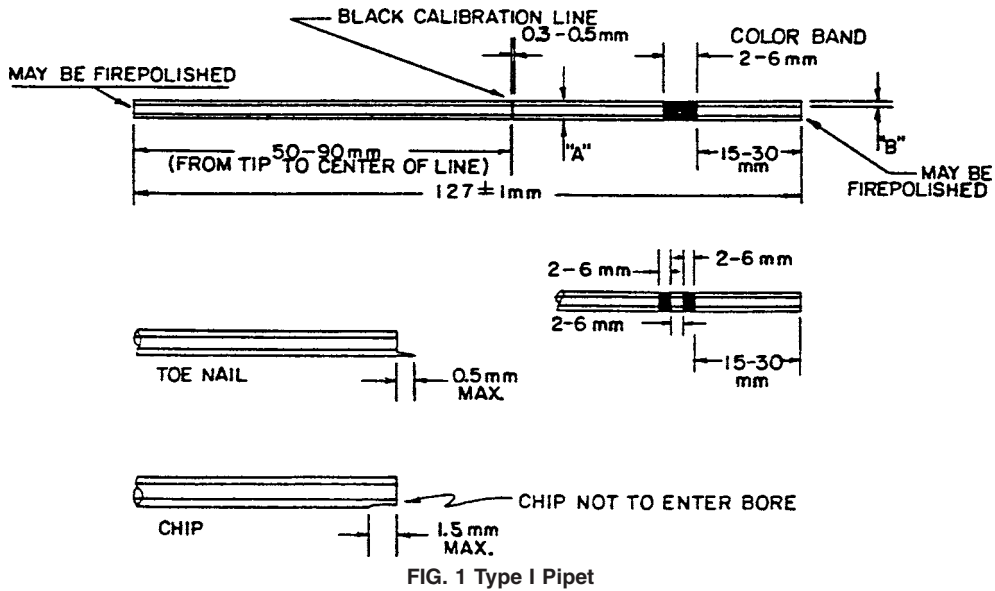

FIG. 1 Type I Pipet

TABLE 1 Dimensions for Type I Pipet

Stated Capacity, μL	Color Code	Minimum Di- ameter A, mm	Minimum Wall B, mm	Maximum Volumetric Deviation	
				Accuracy, %	Coefficient of Variation, %
5	white	1.0	0.35	±1.0	<1.5
10	orange	1.0	0.25	±0.5	<1.0
20	black	1.1	0.25	±0.5	<1.0
25	2 white	1.1	0.25	±0.5	<1.0
50	green	1.3	0.20	±0.5	<1.0
100	blue	1.6	0.20	±0.5	<1.0
200	red	2.2	0.20	±0.5	<1.0

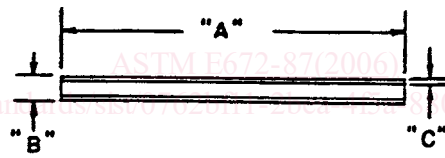

FIG. 2 Type II Pipet

6.2.1 Accuracy (see 4.1)—The accuracy shall be determined as specified in 9.4 and shall be within the limits given in Table 1 and Table 2.

6.2.2 Coefficient of Variation (see section 4.2)—The coefficient of variation shall be determined as specified in 9.4 and shall be within the limits given in Table 1 and Table 2.

6.3 Capacity Mark—Pipets in Fig. 1 shall have a capacity line that is calibrated “to contain” a volume of liquid at 20°C. The capacity line shall be 0.3 to 0.5 mm wide and shall completely encircle the pipet in a plane perpendicular to its longitudinal axis.

6.4 Identification Markings:

6.4.1 Type I—The pipets in Fig. 1 shall be identified for capacity by a color code marking on each pipet consisting of one or two color bands (see Table 1). For a code consisting of one band, the band shall be from 2 to 6 mm wide; for a code consisting of two bands, each band shall be 2 to 6 mm wide and separated with a space of 2 to 6 mm. The color code band, or bands, shall completely encircle the pipet in a plane perpendicular to its longitudinal axis. The location of color band, or