



Designation: D6369 – 99(Reapproved 2006)

Standard Guide for Design of Standard Flashing Details for EPDM Roof Membranes¹

This standard is issued under the fixed designation D6369; the number immediately following the designation indicates the year of original adoption or, in the case of revision, the year of last revision. A number in parentheses indicates the year of last reapproval. A superscript epsilon (ϵ) indicates an editorial change since the last revision or reapproval.

1. Scope

1.1 This guide covers the design of details for typical conditions encountered in new ballasted, mechanically attached or fully adhered ethylene propylene diene terpolymer (EPDM) sheet roof systems.

1.2 This guide illustrates general details for typical conditions that may be encountered on an EPDM sheet roofing system. The guide will assist the designer in preparing details for each specific condition that may occur on a project.

1.3 The values stated in SI units are to be regarded as standard. The conventional units given in parentheses are provided for information purposes only.

1.4 *This standard does not purport to address all of the safety concerns, if any, associated with its use. It is the responsibility of the user of this standard to establish appropriate safety and health practices and determine the applicability of regulatory limitations prior to use.*

2. Referenced Documents

2.1 *ASTM Standards:*²

D1079 Terminology Relating to Roofing and Waterproofing

3. Terminology

3.1 *Definitions*— For definitions of terms used in this guide and not listed below, see Terminology **D1079**.

3.2 *ballasted sheet roofing, n*—a system which incorporates a loose laid vulcanized EPDM sheet over an accepted substrate and is held in place with either stone ballast, pavers, or a combination thereof.

3.3 *fully adhered sheet roofing, n*—a system which incorporates a vulcanized EPDM sheet fully adhered over a secured and accepted substrate.

¹ This guide is under the jurisdiction of ASTM Committee **D08** on Roofing and Waterproofing and is the direct responsibility of Subcommittee **D08.18** on Nonbituminous Organic Roof Coverings.

Current edition approved Dec. 1, 2006. Published December 2006. Originally approved in 1999. Last previous edition approved in 1999 as D6369 – 99. DOI: 10.1520/D6369-99R06.

² For referenced ASTM standards, visit the ASTM website, www.astm.org, or contact ASTM Customer Service at service@astm.org. For *Annual Book of ASTM Standards* volume information, refer to the standard's Document Summary page on the ASTM website.

3.4 *mechanically attached sheet roofing, n*—a system which incorporates a mechanically fastened vulcanized EPDM sheet over a secured and accepted substrate.

4. Significance and Use

4.1 This guide illustrates general details for typical conditions that may be encountered on an EPDM sheet roofing system.

4.2 This guide does not address all requirements associated with the installation of EPDM membrane flashing, such as membrane cleaning and surface preparation, fastener spacing, adhesive application and other seaming requirements which may vary by membrane system supplier.

4.3 Insulation, fastener types, protection mats, stone ballast, pavers, and requirements for perimeter attachment are not covered by this guide. The designer shall review the project requirements and consult the membrane system supplier, building insurer, and local building codes for specific requirements.

5. Drawings

5.1 This guide is not all-inclusive. The designer shall detail all typical and special conditions on the project. Particular attention shall be given to transitions in plane and intersection of different details. The membrane system supplier or system applicator shall provide shop drawings of each condition to confirm field conditions and to verify their understanding of the design intent.

5.2 Insulation, protection mats, stone ballast and pavers have been omitted for clarity.

5.3 Treated wood blocking shall be installed to provide attachment for accessory items such as gravel stops, metal sleeves, etc.

6. Penetrations

6.1 Flashing at penetrations shall accommodate differential movement between the deck and penetration (that is, pipe, conduit, column or drain).

6.1.1 Where “H” or “T” column sections occur, install blocking between flanges to facilitate installation of flashing. Weld sloping steel hoods to column. Extend vertical leg of hood a minimum 100 mm (4 in.) over flashing.

6.1.2 Set cast iron drains with the top of the flange level with or slightly below the surrounding deck area. When insulation is installed below the sheet membrane provide a minimum 900 by 900 mm (36 by 36 in.) transition sump. Do not run field or factory seams within 600 mm (24 in.) of drain flange edge.

7. Expansion Joints

7.1 Expansion joints are designed to permit independent movement of structural elements on each side of the joint. Expansion joint curbs and flashings shall be designed to accommodate this movement. Expansion joints shall be raised a minimum 200 mm (8 in.) above the roof membrane.

8. Explanatory Notes

8.1 *Perimeter Terminations*—The most common perimeter terminations are shown in Fig. 1. Extend sheet roofing membrane down the building face covering the joint between the wood blocking and exterior building finish a minimum 25 mm (1 in.). Install the gravel stop as specified by the designer or manufacturer. Where sheet metal gravel stops are installed, surfaces of the metal shall be primed with the manufacturer's recommended primer prior to application of the EPDM flashing.

8.1.1 Where the perimeter terminates at a gutter, extend the EPDM field membrane behind the gutter. Flash the gutter or gravel stop flange. Alternately, install a perforated gravel guard on ballasted systems.

8.2 *Intersection of Horizontal and Vertical Planes*—The intersection of the horizontal and vertical planes are shown in Fig. 2. Mechanically fasten a 150 mm (6 in.) wide reinforced EPDM strip to the substrate as indicated. Adhere the EPDM membrane to the strip extending vertically a minimum 200 mm (8 in.). Alternately, mechanically fasten the EPDM sheet onto the horizontal or vertical substrate. Apply an EPDM sheet as flashing to the vertical surface at a minimum height of 200 mm (8 in.) extending onto the horizontal surfaces a minimum 75 mm (3 in.) for vulcanized or non-vulcanized sheets.

8.3 *Flashing Vent Stacks*—Two methods for flashing vent stacks are shown in Fig. 3. Extend flashings a minimum 200 mm (8 in.) vertically. Where required, extend prefabricated flashing boot by field wrapping vent stack with non-vulcanized EPDM.

8.4 *Sump Transition*— Provide a smooth sump transition from the top of the insulation to the drain flange as shown in Fig. 4. The membrane shall extend over the drain flange and terminate a minimum 13 mm (½ in.) beyond the drain clamping ring attachment points. Apply water seal to drain flange prior to membrane installation. Install the clamping ring to provide uniform compression on the water seal. Do not run factory or field seams within 600 mm (24 in.) of drain flange edge.

8.5 *Membrane Installation at Parapets* —At parapets (not exceeding 600 mm (24 in.) in height) the membrane shall extend over the top surface and down the parapet face as shown in Fig. 5. Where wood blocking is installed, the membrane

shall lap the joint between the wood blocking and parapet surface a minimum 25 mm (1 in.).

8.6 *Expansion Joints*— As shown in Fig. 6, expansion joints shall be raised above the roof membrane a minimum 200 mm (8 in.). A compressible tube or proprietary formed member is used to permit the membrane to flex. An EPDM hammock is installed to support the joint insulation and tube. If the expansion joint curb is constructed of wood blocking, then the top surfaces shall be beveled to provide a positive slope away from the joint. An alternate method is to install a prefabricated or metal expansion joint cover to the top of the expansion joint.

8.7 *Scuppers*—Scuppers shall be fabricated from sheet metal with soldered or sealed seams as shown in Fig. 7. The flanges shall be set in water seal and flashed. Seal the exterior portion of the scupper to the vertical surfaces.

8.8 *Membrane Termination on Vertical Surface*—Where the membrane terminates on a vertical surface (see Fig. 8), it shall be secured with fasteners a maximum 200 mm (8 in.) outside circumference or a metal termination bar that is fastened a maximum 200 mm (8 in.) outside circumference. Extend membrane under the cap flashing a minimum 75 mm (3 in.). Surface mounted metal counterflashings, flashings or termination bars shall be used in concrete surfaces only.

8.9 *Raised Curbs*— Skylight and ventilator covers and other similar items shall be installed on a raised curb as shown in Fig. 9. The curb can be prefabricated or constructed of wood blocking. If a prefabricated curb is utilized, the EPDM membrane shall extend under the flange of the curb and the curb secured to the substrate. Alternately, if the curb is constructed of wood blocking, mechanically fasten the EPDM membrane to the horizontal or vertical substrate. Apply an EPDM sheet to the vertical surface at a minimum height of 200 mm (8 in.) extending onto the horizontal surfaces a minimum 75 mm (3 in.) for vulcanized or non-vulcanized sheets.

8.10 *Multiple Roof Penetrations* —Where the roof is penetrated with multiple piping or conduits, they shall be made weathertight by utilizing a metal hood secured to a prefabricated or wood curb as shown in Fig. 10. The curb shall be flashed as indicated in 8.9. The piping should be sloped downward to prevent water entry into the hood.

8.11 *Flashing Hot Pipes or Flues* —Hot pipes or flues shall be flashed with a metal sleeve and hood as shown in Fig. 11. Extend the EPDM membrane under the horizontal flange of the sleeve and attach the flange to the substrate. Apply an EPDM sheet to the vertical surface of the sleeve (a minimum height of 200 mm (8 in.)). Extend the sheet onto the horizontal surfaces a minimum 75 mm (3 in.) for vulcanized or non-vulcanized sheets.

8.12 *"H" or "I" Column Sections*—As shown in Fig. 12, where "H" or "I" column sections occur, install blocking of either steel or wood between flanges to facilitate installation of flashing. Weld sloping steel hood to column, extending the vertical leg a minimum 100 mm (4 in.) over flashing. Alternately, install a sheet metal cap flashing to the vertical leg.

9. Keywords

9.1 EPDM; expansion joint; flashing; parapets; roof drain

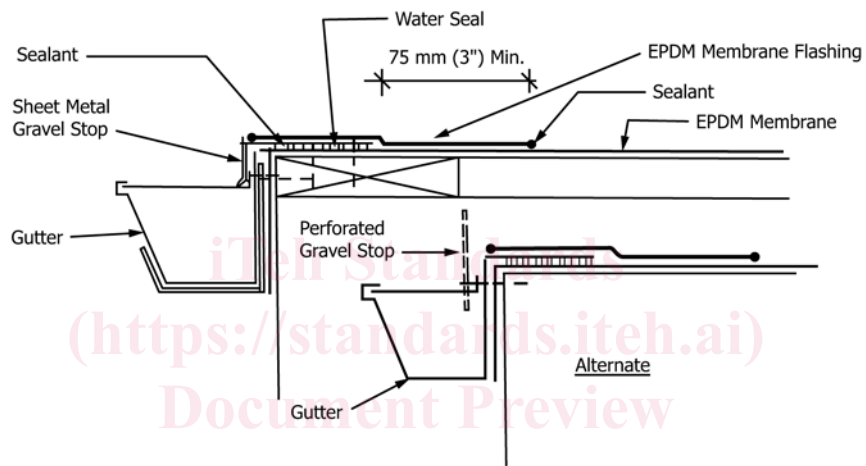
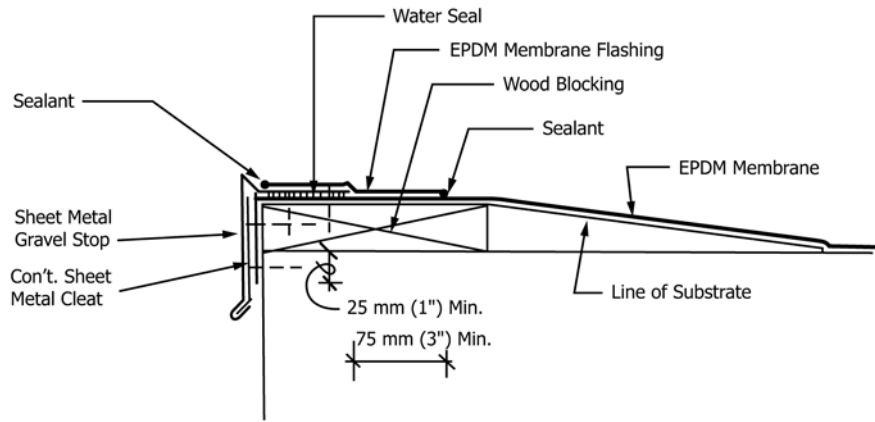

ASTM D6369-99(2006)

<https://standards.iteh.ai/catalog/standards/sist/6167f116-9fde-4f64-98be-6e79b7465281/astm-d6369-992006>

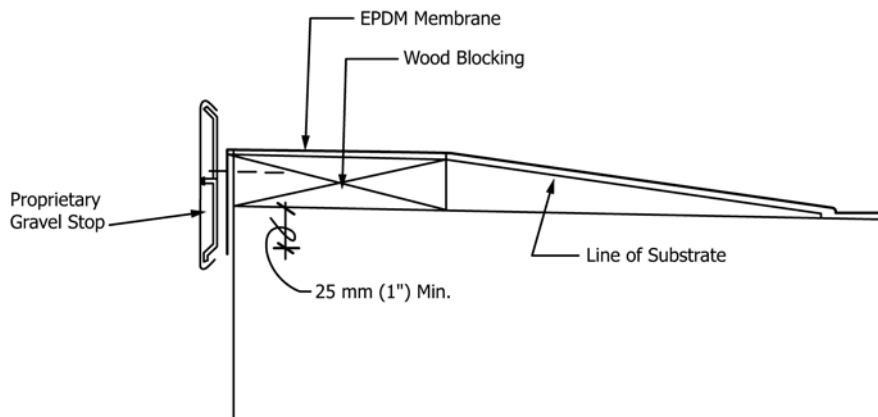

FIG. 1 Common Perimeter Terminations

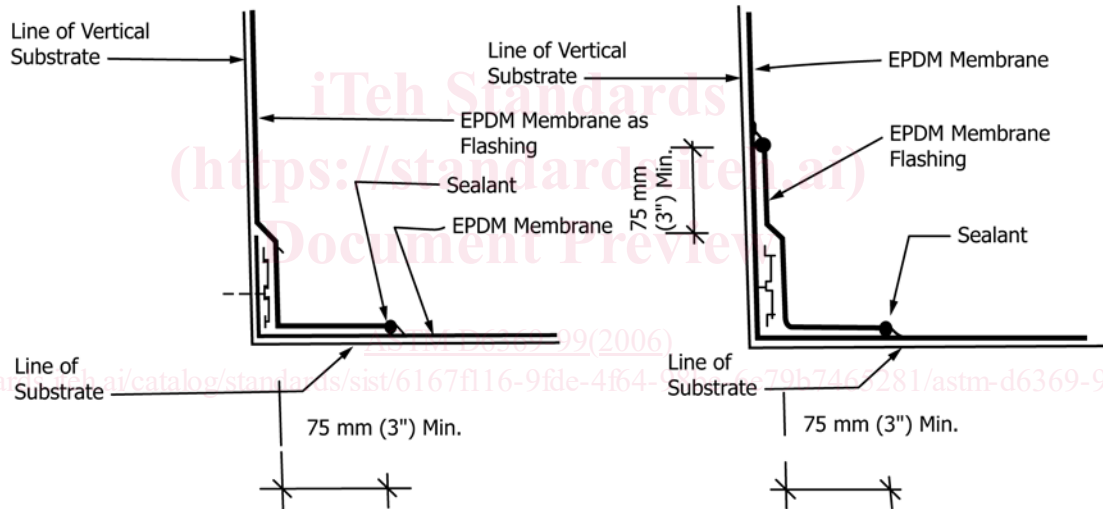
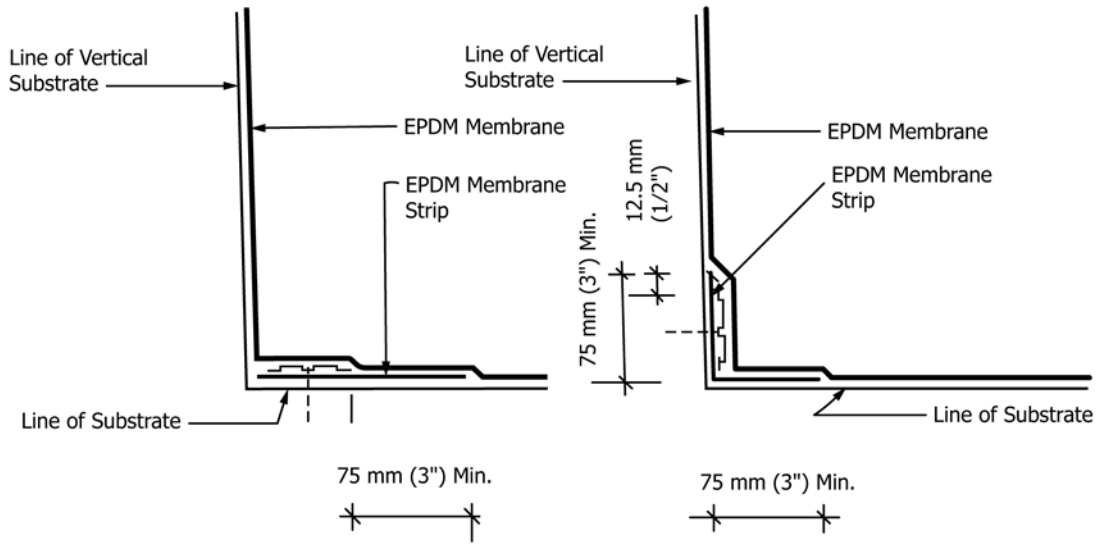

FIG. 2 Intersection of Horizontal and Vertical Planes

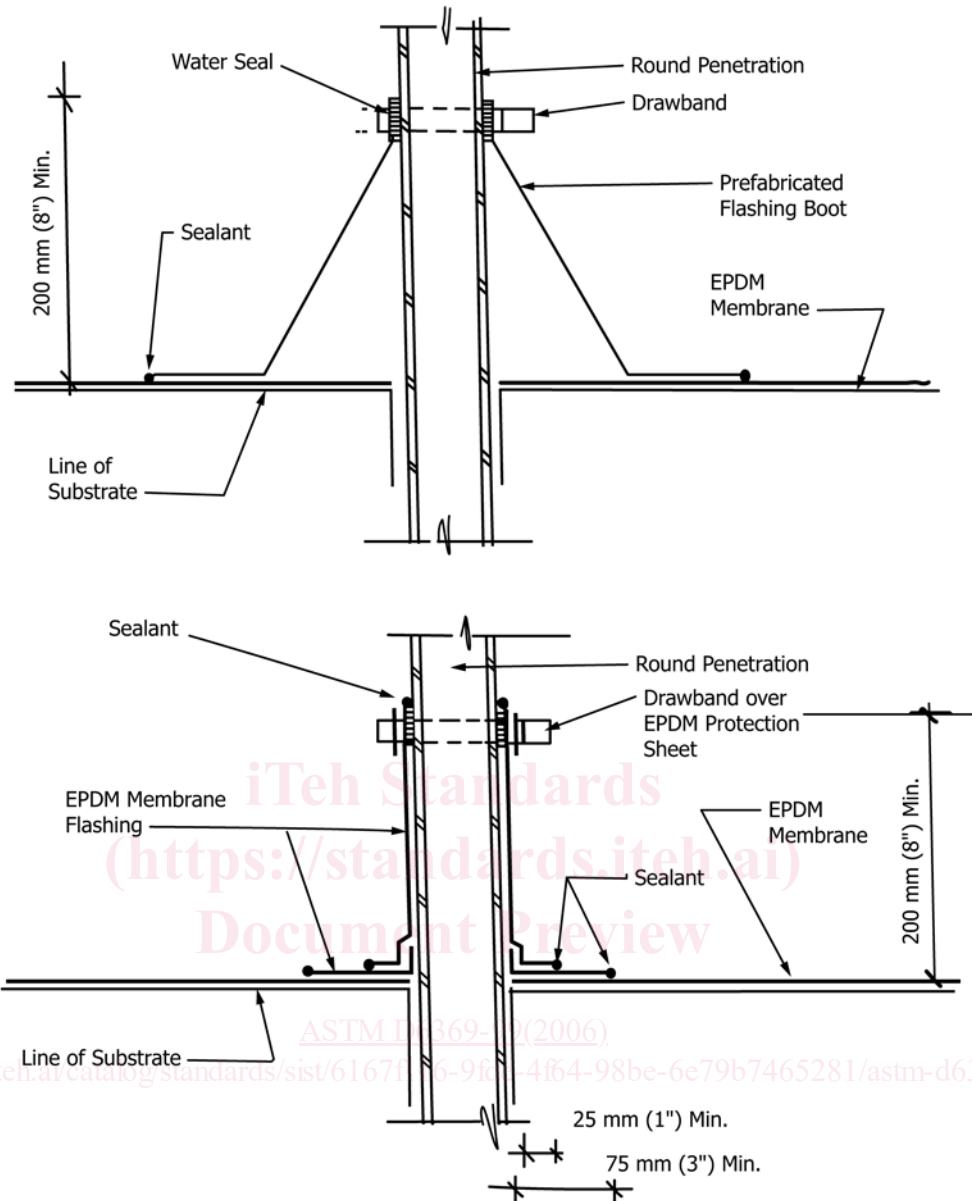
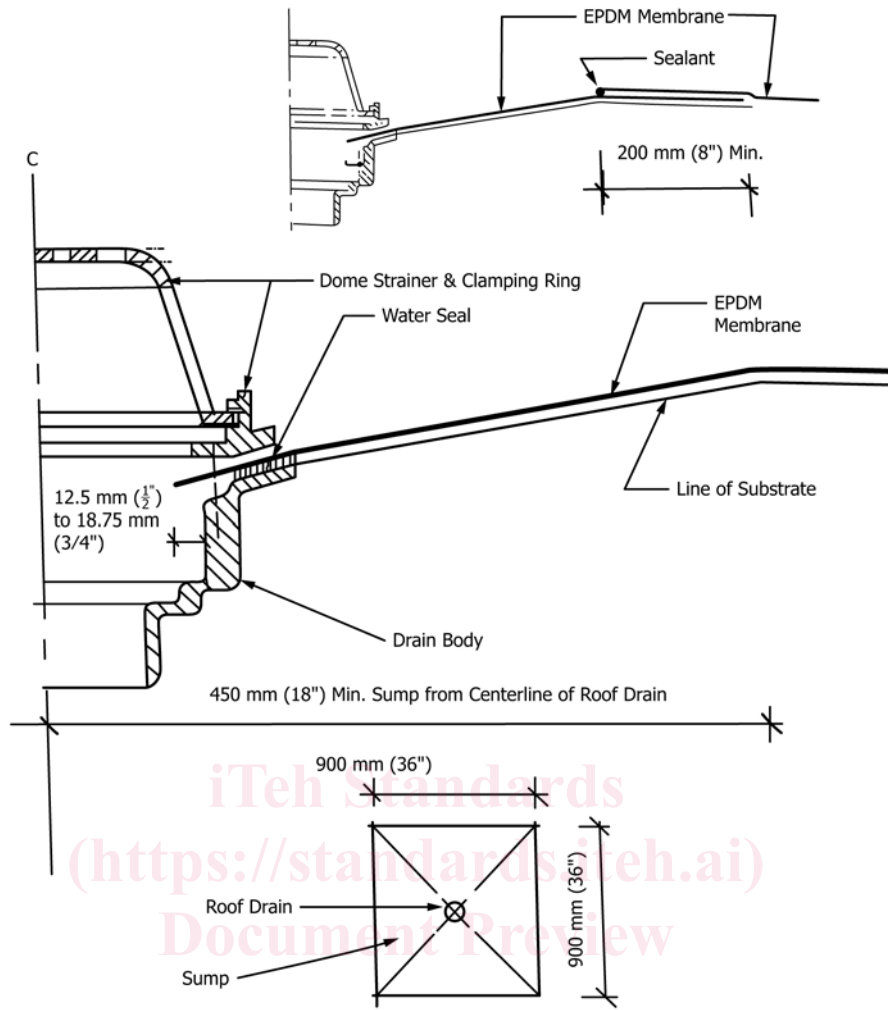

FIG. 3 Flashing Vent Stacks



ASTM FIG. 4 Sump Transition

<https://standards.itech.ai/catalog/standards/sist/6167f116-9fde-4f64-98be-6e79b7465281/astm-d6369-992006>