**Resilient and laminate floor coverings —
Determination of indentation and residual
indentation —**

**Part 2:
Short-term residual indentation of
resilient floor covering**

iTeh STANDARD PREVIEW
(standards.iteh.ai)

*Revêtements de sol résilients et stratifiés — Détermination du
poinçonnement et du poinçonnement rémanent —*

*Partie 2: Poinçonnement rémanent de courte durée des revêtements de
sol résilients*

<https://standards.iteh.ai/catalog/standards/sist/74bd9eaf-0f19-4b9f-868b-d0d09cc447d7/iso-24343-2-2011>



iTeh STANDARD PREVIEW (standards.iteh.ai)

ISO 24343-2:2011

<https://standards.iteh.ai/catalog/standards/sist/74bd9eaf-0f19-4b9f-868b-d0d09cc447d7/iso-24343-2-2011>



COPYRIGHT PROTECTED DOCUMENT

© ISO 2011

All rights reserved. Unless otherwise specified, no part of this publication may be reproduced or utilized in any form or by any means, electronic or mechanical, including photocopying and microfilm, without permission in writing from either ISO at the address below or ISO's member body in the country of the requester.

ISO copyright office
Case postale 56 • CH-1211 Geneva 20
Tel. + 41 22 749 01 11
Fax + 41 22 749 09 47
E-mail copyright@iso.org
Web www.iso.org

Published in Switzerland

Foreword

ISO (the International Organization for Standardization) is a worldwide federation of national standards bodies (ISO member bodies). The work of preparing International Standards is normally carried out through ISO technical committees. Each member body interested in a subject for which a technical committee has been established has the right to be represented on that committee. International organizations, governmental and non-governmental, in liaison with ISO, also take part in the work. ISO collaborates closely with the International Electrotechnical Commission (IEC) on all matters of electrotechnical standardization.

International Standards are drafted in accordance with the rules given in the ISO/IEC Directives, Part 2.

The main task of technical committees is to prepare International Standards. Draft International Standards adopted by the technical committees are circulated to the member bodies for voting. Publication as an International Standard requires approval by at least 75 % of the member bodies casting a vote.

Attention is drawn to the possibility that some of the elements of this document may be the subject of patent rights. ISO shall not be held responsible for identifying any or all such patent rights.

ISO 24343-2 was prepared by Technical Committee ISO/TC 219, *Floor coverings*.

ISO 24343 consists of the following parts, under the general title *Resilient and laminate floor coverings — Determination of indentation and residual indentation*:

- *Part 1: Residual indentation*
- *Part 2: Short-term residual indentation of resilient floor covering*
- *Part 3: Indentation of resilient semi-flexible/vinyl composition tiles*

ISO 24343-2:2011

<https://standards.iteh.ai/catalog/standards/sist/74bd9eaf-0f19-4b9f-868b-d0d09cc447d7/iso-24343-2-2011>

iTeh STANDARD PREVIEW
(standards.iteh.ai)

ISO 24343-2:2011

<https://standards.iteh.ai/catalog/standards/sist/74bd9eaf-0f19-4b9f-868b-d0d09cc447d7/iso-24343-2-2011>

Resilient and laminate floor coverings — Determination of indentation and residual indentation —

Part 2: Short-term residual indentation of resilient floor covering

1 Scope

This part of ISO 24343 describes a method for determining the short-term indentation and residual indentation produced in a resilient floor covering after the application and removal of a constant load.

2 Terms and definitions

For the purposes of this document, the following terms and definitions apply.

2.1

indentation

difference between the initial thickness and the thickness measured after removal of the load

2.2

residual indentation

difference between the initial thickness and the thickness measured after removal of the load and a specified recovery period

2.3

thickness

distance between two parallel plates where the floor covering is inserted under a specific load

iTeh STANDARD PREVIEW
(standards.iteh.ai)

[ISO 24343-2:2011](https://standards.iteh.ai/catalog/standards/sist/74bd9eaf-0f19-4b9f-868b-d0d09cc447d7/iso-24343-2-2011)

<https://standards.iteh.ai/catalog/standards/sist/74bd9eaf-0f19-4b9f-868b-d0d09cc447d7/iso-24343-2-2011>

3 Principle

A test piece is subjected to a static loading, the thickness being measured before loading, after removal of the load and after a specified recovery period.

4 Apparatus

4.1 Indenter, a straight, steel cylinder of diameter as specified below with a hemispherical foot.

Diameter of the indenter: $(19,05 \pm 0,01)$ mm; weight of the indenter: $(0,45 \pm 0,05)$ kg.

4.2 Rigid, horizontal platform, of minimum diameter 35 mm.

4.3 Device, by means of which a force of 22,7 kg can be smoothly applied. The frame shall not deform by more than 0,05 mm measured in the direction of the axis under the maximum force.

4.4 Comparator, for measuring the depth of indentation to $\pm 0,025$ mm.

4.5 Apparatus for measuring the thickness of the test piece to 0,01 mm.

Diameter of the flat foot: $(3,50 \pm 0,02)$ mm ; mass applied $(0,085 \pm 0,003)$ kg.

4.6 Stopwatch.

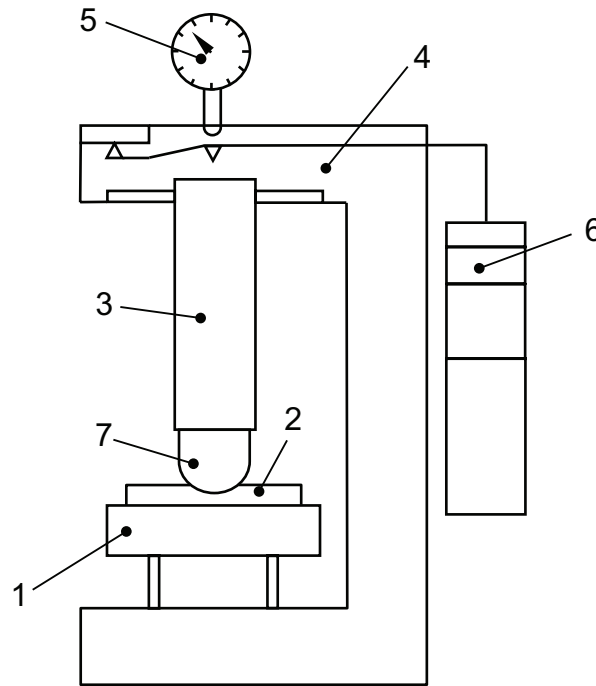

- Key**
- 1 horizontal platform
 - 2 test piece
 - 3 annula weight
 - 4 lever arm
 - 5 comparator
 - 6 dead weight
 - 7 indenter

iTeh STANDARD PREVIEW
(standards.iteh.ai)

<https://standards.iteh.ai/catalog/standards/sist/74bd9eaf-0f19-4b9f-868b-d0d09cc447d7/iso-24343-2-2011>

Figure 1 — Example of a device to apply force on an indenter

5 Atmosphere for conditioning and testing

Condition the test piece at a temperature of $(23 \pm 2) ^\circ\text{C}$ and a relative humidity of $(50 \pm 5) \%$ for a minimum of 24 h. Maintain these conditions when carrying out the test.

6 Sampling and selection of specimens

Take a representative sample from the available material. Take three test pieces with dimensions at least 50 mm by 50 mm cut from a roll or different tiles or planks.

7 Test procedure

- 7.1 Mark the place of measurement and measure the initial thickness of the test piece, t_0 , at its centre to 0,01 mm, using the appropriate mass specified in 4.5.
- 7.2 Zero comparator on base (horizontal platform).
- 7.3 Place the test piece on the platform.

7.4 Place the indenter on the marked spot and gently apply the total force specified in 4.3 and start the stopwatch within 2 s.

7.5 Record the depth of indentation after (15 ± 1) s to 0,01 mm, t_1 .

7.6 Record the depth of indentation after (300 ± 2) s to 0,01 mm, t_2 , and remove the force and the test piece from the platform.

7.7 After a further (150 ± 1) m, measure the final thickness of the test piece, t_3 , at the marked position, using the appropriate apparatus in 4.5.

7.8 Repeat the test on the remaining test pieces. Calculate the mean value from the measurements taken and express the result to 0,01 mm.

8 Calculation and expression of results

Calculate the indentation at (15 ± 1) s, $t_0 - t_1$, for each test piece.

Calculate the indentation at (300 ± 2) s, $t_0 - t_2$, for each test piece.

Calculate the residual indentation, $t_0 - t_3$, for each test piece.

9 Precision statement

A round robin test shall be conducted to determine the precision of this test method.

10 Test report

The test report shall contain the following information:

- a) a statement that the tests were performed in accordance with this part of ISO 24343, i.e. ISO 24343-2;
- b) complete identification of the product tested, including type, source, colour, and manufacturer's reference numbers;
- c) history of the sample;
- d) the mean value for the initial thickness to the nearest 0,02 mm;
- e) the mean value for the depth of indentation at 15 s to the nearest 0,02 mm;
- f) the mean value for the depth of indentation at 300 s to the nearest 0,02 mm;
- g) the mean value for residual indentation at 150 m to the nearest 0,02 mm;
- h) any deviation from this part of ISO 24343, which could have affected the results.

Bibliography

- [1] ASTM F 1914, Standard Test Methods for Short-Term Indentation and Residual Indentation of Resilient Floor Covering
- [2] JIS A 1454, Test methods — Resilient floorcoverings

iTeh STANDARD PREVIEW
(standards.iteh.ai)

[ISO 24343-2:2011](https://standards.iteh.ai/catalog/standards/sist/74bd9eaf-0f19-4b9f-868b-d0d09cc447d7/iso-24343-2-2011)

<https://standards.iteh.ai/catalog/standards/sist/74bd9eaf-0f19-4b9f-868b-d0d09cc447d7/iso-24343-2-2011>

iTeh STANDARD PREVIEW
(standards.iteh.ai)

ISO 24343-2:2011

<https://standards.iteh.ai/catalog/standards/sist/74bd9eaf-0f19-4b9f-868b-d0d09cc447d7/iso-24343-2-2011>