



Designation: D 3907 - 92

AMERICAN SOCIETY FOR TESTING AND MATERIALS  
1916 Race St. Philadelphia, Pa 19103  
Reprinted from the Annual Book of ASTM Standards. Copyright ASTM  
If not listed in the current combined index, will appear in the next edition.

## Standard Method for Testing Fluid Catalytic Cracking (FCC) Catalysts by Microactivity Test<sup>1</sup>

This standard is issued under the fixed designation D 3907; the number immediately following the designation indicates the year of original adoption or, in the case of revision, the year of last revision. A number in parentheses indicates the year of last reapproval. A superscript epsilon ( $\epsilon$ ) indicates an editorial change since the last revision or reapproval.

### 1. Scope

1.1 This test method covers determining the activity of equilibrium or laboratory-deactivated fluid catalytic cracking (FCC) catalysts, or both. This is evaluated on the basis of weight percent conversion of gas oil in a microactivity unit. The selectivity of FCC catalysts can be determined using Test Method D 5154.

1.2 The values stated in SI units are to be regarded as standard. The values given in parentheses are provided for information only.

1.3 *This standard does not purport to address all of the safety problems, if any, associated with its use. It is the responsibility of the user of this standard to establish appropriate safety and health practices and determine the applicability of regulatory limitations prior to use.*

### 2. Referenced Documents

#### 2.1 ASTM Standards:

D 2887 Test Method for Boiling Range Distribution of Petroleum Fractions by Gas Chromatography<sup>2</sup>

D 5154 Test Method for Determining the Activity and Selectivity of Fluid Catalytic Cracking (FCC) Catalysts by Microactivity Test<sup>3</sup>

E 105 Practice for Probability Sampling of Materials<sup>4</sup>

E 177 Practice for Use of the Terms Precision and Bias in ASTM Test Methods<sup>4</sup>

E 456 Terminology Relating to Quality and Statistics<sup>4</sup>

E 691 Practice for Conducting an Interlaboratory Study to Determine the Precision of a Test Method<sup>4</sup>

### 3. Terminology

#### 3.1 Descriptions of Terms Specific to This Standard:

3.1.1 *ASTM standard feed*—a specific batch of gas oil that is used as feedstock in the described method. This standard feed can be obtained from the National Institute of Standards and Technology (NIST).<sup>5</sup>

3.1.2 *ASTM reference catalysts*—a set of equilibrium fluid cracking catalysts with conversions within the useful range of this method is used to improve the reproducibility

of test results between different laboratories. Samples of the ASTM reference catalysts can be obtained from NIST.

3.1.3 *measured conversion*—is calculated as the difference between the weight of feed used and the weight of unconverted material, divided by the weight of feed used, times 100 %. The unconverted material is defined as all liquid product with a boiling point above 216°C (421°F).

3.1.4 *ASTM consensus mean conversion*—each reference catalyst has a consensus mean conversion value assigned to it by Committee D-32 (see 11.2).

3.1.5 *conversion calibration curve*—a calibration curve can be obtained by plotting the consensus mean conversion values for the ASTM reference catalysts (see 11.2) versus the individual laboratory-measured conversion for the same catalysts.

### 4. Summary of Test Method

4.1 A sample of cracking catalyst in a fixed-bed reactor is contacted with gas oil (ASTM standard feed). Cracked liquid products are analyzed for unconverted material and the conversion is calculated.

4.2 A corrected conversion value can be obtained from the measured conversion and the conversion calibration curve.

### 5. Significance and Use

5.1 The microactivity test provides data to assess the relative performance of FCC catalyst. Because results are affected by catalyst pretreatment, feedstock characteristics, test equipment, and operating parameters, adherence to this test method is a prerequisite for correct interpretation of results. Apparatus, test conditions, and analytical procedures actually used should closely resemble those described in this method.

5.2 Caution should be used in interpreting results above 80 weight % conversion due to the significance of overcracking.

### 6. Apparatus

6.1 *Flow Chart*—The flow chart is given in Fig. 1. During 75 s, gas oil from a syringe is forced over 4 g of catalyst in a fixed-bed reactor. Liquid products are collected in a receiver and kept at a wet ice temperature.

6.2 *Syringe*, 2.5 mL is used for oil addition. It should be equipped with a multiport, high-pressure valve to allow nitrogen and oil entry to the reactor through a common feed line.

6.3 *Syringe Heater*—Heat syringe to  $40 \pm 5^\circ\text{C}$  ( $104 \pm 9^\circ\text{F}$ ) using a heat lamp or resistance heater or any other suitable means.

<sup>1</sup> This test method is under the jurisdiction of ASTM Committee D-32 on Catalysis and is the direct responsibility of Subcommittee D32.04 on Catalytic Properties.

Current edition approved Jan. 15, 1992. Published March 1992. Originally published as D 3907 - 80. Last previous edition D 3907 - 87.

<sup>2</sup> Annual Book of ASTM Standards, Vol 05.02.

<sup>3</sup> Annual Book of ASTM Standards, Vol 05.03.

<sup>4</sup> Annual Book of ASTM Standards, Vol 14.02.

<sup>5</sup> National Institute of Standards and Technology (NIST), Gaithersburg, MD 20899.

## D 3907

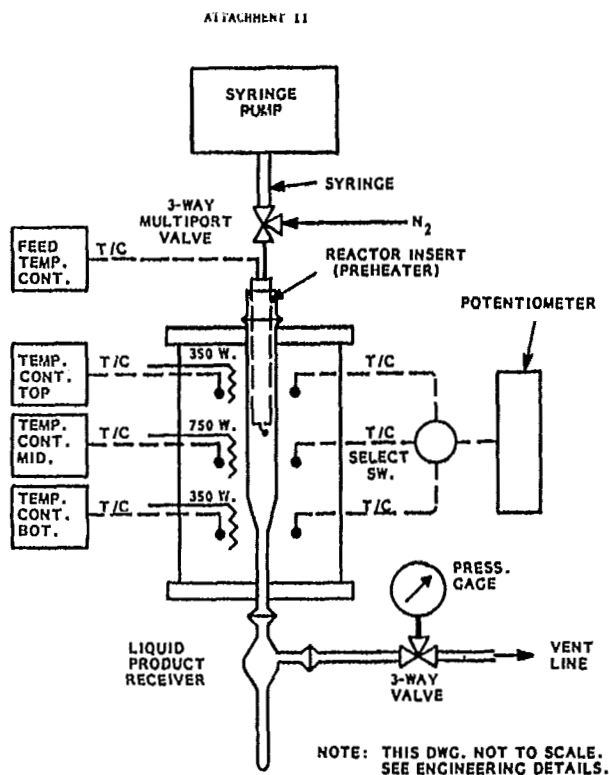

NOTE—This drawing, not to scale. For engineering details, see other drawings.

FIG. 1 Micro-Activity Flow Chart

6.4 *Syringe Pump*—A syringe pump that can deliver uniform flow of  $1.33 \pm 0.03$  g of gas oil in  $75 \pm 1$  s.

6.5 *Furnace*—A three-zone furnace is used: middle zone 150-mm (6-in.) length and top and bottom zones 75-mm (3-in.) length. The catalyst bed is positioned in the middle zone. The temperature controllers of the three zones are calibrated to achieve a constant temperature  $482 \pm 1^\circ\text{C}$  ( $900 \pm 2^\circ\text{F}$ ) over the whole length of the catalyst bed (actual bed temperature).

6.6 *Reactor and Insert*—A glass or stainless steel reactor of 15.6 mm internal diameter is used. Dimensions are shown in Fig. 2. Details of the reactor insert are shown in Figs. 2 and 3.<sup>6</sup>

6.7 *Liquid Product Collection System*—Liquid product is collected in the receiver shown in Fig. 4.

6.8 *Analytical Balance and Weights*—The balance used to weigh the sample, the receiver, and the syringe shall have a precision of 1 mg. Analytical weights shall be precision grade or calibrated against a set of certified standard weights.

6.9 *Chromatographic Equipment*—The gas chromatographic equipment specified in Test Method D 2887 is suggested for the analysis of liquid product. A flame ionization detector is recommended.

## 7. Sampling

7.1 If a sampling procedure is desired, Practice E 105 is recommended.

<sup>6</sup> General dimensions are given in SI units. Dimensions given in SAE, U.S. Standard gage sizes for sheet, tubing, and wire are considered standard. In general, the closest metric equivalent should be adequate for proper functioning.

## 8. Sample Preparation

8.1 Dry samples or decoke, or both, by heating a shallow (less than 10 mm thick) bed of catalyst in a porcelain crucible as follows:

- $120 \pm 20^\circ\text{C}$  ( $248 \pm 36^\circ\text{F}$ ) for 1 h
- $120^\circ\text{C}$  ( $248^\circ\text{F}$ ) to  $590^\circ\text{C}$  ( $1094^\circ\text{F}$ ) approximately 1 h
- $590 \pm 20^\circ\text{C}$  ( $1094 \pm 36^\circ\text{F}$ ) for 3 h

8.2 Sufficient air should be available in the furnace to burn the sample free of coke. Insufficient decoking is indicated by a difference in color of the top and bottom layers. The hot crucible is cooled in a desiccator to prevent moisture pickup.

## 9. Procedure

### 9.1 Reactor Preparation:

9.1.1 Rinse the feed line with acetone or other suitable solvent and dry with air. Periodic cleaning of the insert is recommended by an air purge at  $482^\circ\text{C}$  ( $900^\circ\text{F}$ ) for 1 h, at least once every 12 tests.

9.1.2 Wash the reactor and product receiver thoroughly with acetone or other suitable solvent and dry. If necessary, burn out any coke deposited in the reactor by heating in air at  $482^\circ\text{C}$  ( $900^\circ\text{F}$ ) prior to washing.

9.1.3 Insert a plug of quartz or borosilicate glass wool (about 20-mm length) into the reactor. Add  $4.00 \pm 0.05$  g of catalyst in a free-flowing manner. Tap the reactor *lightly* to ensure good radial distribution (do not pack). Position another plug of quartz or glass wool (about 6-mm length) above the catalyst bed. Do not tamp wool plugs excessively.

9.1.4 Inspect the reactor feed tube insert to be sure it is free of deposits and the tip of the thermocouple (see Fig. 3, Detail 2) is bent under the tip of the syringe needle. (This is necessary to control the oil preheat temperature accurately.) Place the insert in the reactor and adjust, if necessary, so that the insert needle is between 10 to 50 mm above the catalyst bed. Place the reactor in the furnace that has been preheated to  $482^\circ\text{C}$  ( $900^\circ\text{F}$ ) and connect the nitrogen purge line directly to the reactor feed line. Purge with 30 sccm/min of nitrogen for at least 30 min.

9.1.5 Make electrical connections on the integral oil feed preheater and connect the thermocouple to the recorder.

### 9.2 Preparation of Syringe and Liquid Product Receiver:

9.2.1 Fill the syringe with ASTM standard feed and invert to allow air to rise.

NOTE: 1—The ASTM standard feed is very viscous at  $<30^\circ\text{C}$ ; therefore, loading the syringe and removal of air bubbles can be facilitated by preheating the oil to  $40 \pm 5^\circ\text{C}$  ( $104 \pm 9^\circ\text{F}$ ).

9.2.2 Remove the air bubbles. The syringe should contain a small amount of oil in excess of the nominal volume to be charged.

9.2.3 After the syringe is filled and the valve is in correct position, blow excess oil out of the valve and clean the outside of the syringe.

9.2.4 Weigh the syringe assembly and record the weight.

9.2.5 Disconnect the nitrogen from the reactor feed line, install the syringe, and connect the nitrogen to the syringe valve. Make sure the valve is in the nitrogen flow position. Place a thermocouple (detects temperature of syringe) on the syringe body. Set the syringe temperature at  $40 \pm 5^\circ\text{C}$  ( $104 \pm 9^\circ\text{F}$ ).