



Designation: D5118/D5118M – 05a<sup>ε1</sup>

## Standard Practice for Fabrication of Fiberboard Shipping Boxes<sup>1</sup>

This standard is issued under the fixed designation D5118/D5118M; the number immediately following the designation indicates the year of original adoption or, in the case of revision, the year of last revision. A number in parentheses indicates the year of last reapproval. A superscript epsilon ( $\epsilon$ ) indicates an editorial change since the last revision or reapproval.

*This standard has been approved for use by agencies of the Department of Defense.*

<sup>ε1</sup> NOTE—Section references in subsection 6.2.1.11(2) and 6.4.2.1(1) were editorially corrected in January 2007.

### 1. Scope

1.1 This practice covers the fabrication of new fiberboard boxes, liners and sleeves.

1.2 This practice points out the factors and components that must be controlled in the manufacture of corrugated and solid fiberboard boxes, liners and sleeves.

1.3 This practice does not cover the adequacy of fiberboard containers under all conditions of exposure to atmosphere, handling, shipping and storage.

1.4 The values stated in either inch-pound units or SI units are to be regarded separately as standard. Within the text, the SI units are shown in brackets. The values stated in each system are not exact equivalents; therefore, each system must be used independently of the other. Combining values from the two systems may result in non-conformance with the standard.

1.5 *This standard does not purport to address all of the safety concerns, if any, associated with its use. It is the responsibility of the user of this standard to establish appropriate safety and health practices and determine the applicability of regulatory limitations prior to use.*

### 2. Referenced Documents

#### 2.1 ASTM Standards:<sup>2</sup>

**D685 Practice for Conditioning Paper and Paper Products for Testing**

**D996 Terminology of Packaging and Distribution Environments**

**D1974 Practice for Methods of Closing, Sealing, and Reinforcing Fiberboard Boxes**

**D2658 Test Method for Determining Interior Dimensions of Fiberboard Boxes (Box Gage Method)**

**D3950 Specification for Strapping, Nonmetallic (and Joining Methods)**

**D3951 Practice for Commercial Packaging**

**D3953 Specification for Strapping, Flat Steel and Seals**

**D4727/D4727M Specification for Corrugated and Solid Fiberboard Sheet Stock (Container Grade) and Cut Shapes**

2.2 *Federal Specifications:*<sup>3</sup>

CID A-A-59692 Adhesives, Water-Resistant (For Closure of Fiberboard Boxes)

**FED-STD-123 Marking for Shipment (Civil Agencies)**

**MIL-STD-129 Military Marking for Shipment and Storage**

2.3 *Code of Federal Regulations:*<sup>3</sup>

Title 49

2.4 *Other Publications:*

**National Motor Freight Classification**<sup>4</sup>

**Uniform Freight Classification**<sup>5</sup>

Federal Food, Drug and Cosmetic Act<sup>6</sup>

### 3. Terminology

3.1 Definitions of terms relating to packaging are found in Terminology **D996**.

### 4. Significance and Use

4.1 Corrugated and solid fiberboard boxes, sleeves and liners are used to unitize products into packages of size and shape suitable for manual or mechanical handling and to protect the contents against environmental, handling, shipping, and storage conditions.

4.2 This practice covers some of the basic constructions and styles of commercially available fiberboard packaging used to unitize and protect contents.

4.3 *Use of Other Specifications*—Nothing in this practice shall be construed to prohibit the use of boxes of special design

<sup>1</sup> This practice is under the jurisdiction of ASTM Committee **D10** on Packaging and is the direct responsibility of Subcommittee **D10.27** on Paper and Paperboard Products.

Current edition approved Oct. 1, 2005. Published November 2005. Originally approved in 1990. Last previous edition approved in 2005 as D5118/D5118M – 05. DOI: 10.1520/D5118\_D5118M-05AE01.

<sup>2</sup> For referenced ASTM standards, visit the ASTM website, www.astm.org, or contact ASTM Customer Service at service@astm.org. For *Annual Book of ASTM Standards* volume information, refer to the standard's Document Summary page on the ASTM website.

<sup>3</sup> Available from Standardization Documents, Order Desk, Bldg. 4, Section D, 700 Robbins Ave., Philadelphia, PA 19111-5094, attn: NPODS.

<sup>4</sup> Available from National Motor Freight Classification, Inc., 2200 Mill Road, Alexandria, VA 22314.

<sup>5</sup> Available from National Railroad Freight Committee, 151 Ellis Street, N.E., Suite 260, Atlanta, GA 30335-6021.

<sup>6</sup> Available from the Superintendent of Documents, US Government Printing Office, Washington, DC 20402.

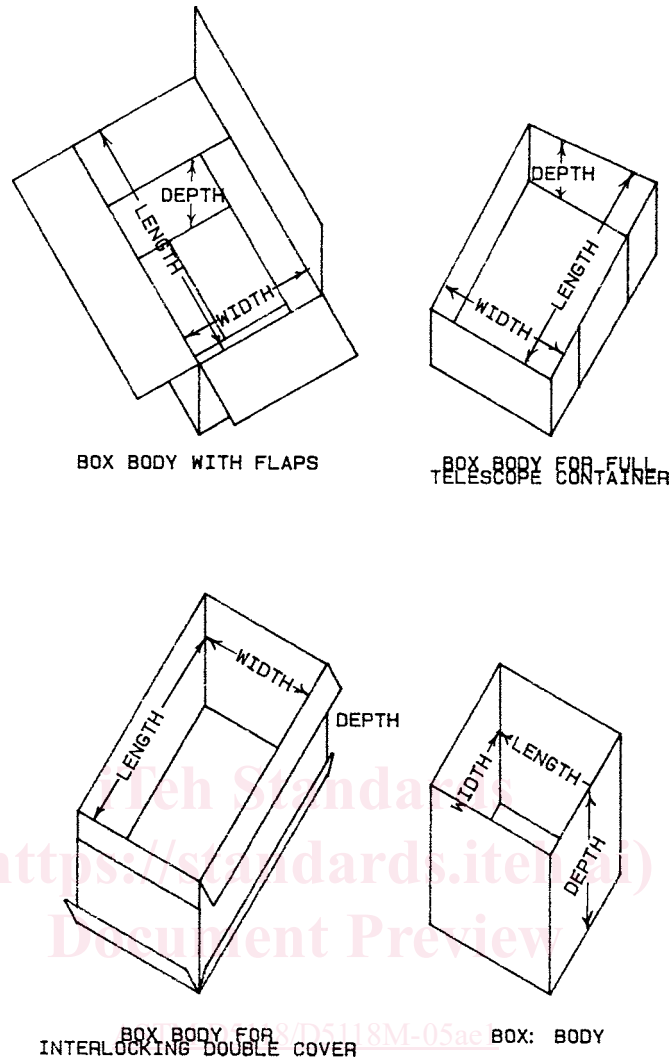

FIG. 1 Fiberboard Box Dimensioning

<https://standards.iteh.ai/catalog/standards/sist/5118-05ae/astm-d5118-d5118m-05ae1>

or of fiberboard packages identified by package number in the current **Uniform Freight Classification** and **National Motor Freight Classification** when in the experience and judgement of the purchaser, the nature of the articles or material to be shipped justifies such boxes or packages. Some commodities may require less protection while other commodities may require better boxes than are specified herein. Containers for explosives and dangerous articles must also comply with regulations for the Transport of Hazardous Materials (CFR Title 49).

## 5. Styles

5.1 Fiberboard boxes covered by this practice may be of the following styles:

- 5.1.1 *RSC/0201*<sup>7</sup>—Regular slotted box (Fig. 8).
- 5.1.2 *OSC/0202*<sup>7</sup>—Overlap slotted box (Fig. 9).
- 5.1.3 *FOL/0203*<sup>7</sup>—Full overlap slotted box (Fig. 10).

<sup>7</sup> Available from European Federation of Manufacturers of Corrugated Board (FEFCO), 37 Rue d'Amsterdam, 75008, Paris, France. Also known as the International Box Code System, that is, in RSC/0201, RSC stands for regular slotted container and 0201 is the international box code number for the RSC.

- 5.1.4 *SFF/0206*<sup>7</sup>—Special full flap slotted box (Fig. 11).
  - 5.1.5 *CSSC/0204*<sup>7</sup>—Center special slotted box (Fig. 12).
  - 5.1.6 *CSOSC/0205*<sup>7</sup>—Center special overlap slotted box (Fig. 12).
  - 5.1.7 *HSCC/0312*<sup>7</sup>—Half slotted box with cover (Fig. 13).
  - 5.1.8 *DBLCC/0310*<sup>7</sup>—Double cover box (Fig. 14).
  - 5.1.9 *IC/0325*<sup>7</sup>—Interlocking double cover box (Fig. 15).
  - 5.1.10 *FTC/0301*<sup>7</sup>—Full telescope box (Fig. 16).
  - 5.1.11 *FTHS/0320*<sup>7</sup>—Full telescope half slotted box (Fig. 18).
  - 5.1.12 *OPF/0401*<sup>7</sup>—One piece folder (Fig. 19).
  - 5.1.13 *FPF/0410*<sup>7</sup>—Five panel folder (Fig. 20).
  - 5.1.14 *TS*—Rigid Box/0600 Series—Bliss Style Box (Fig. 17).
  - 5.1.15 *TSC*—Tongue and slot closure box (Fig. 21).
  - 5.1.16 *TS*—Triple Slide Box (Fig. 22).
- 5.2 Other styles may also be applicable (see 8.1.3).

## 6. Requirements

### 6.1 Materials:

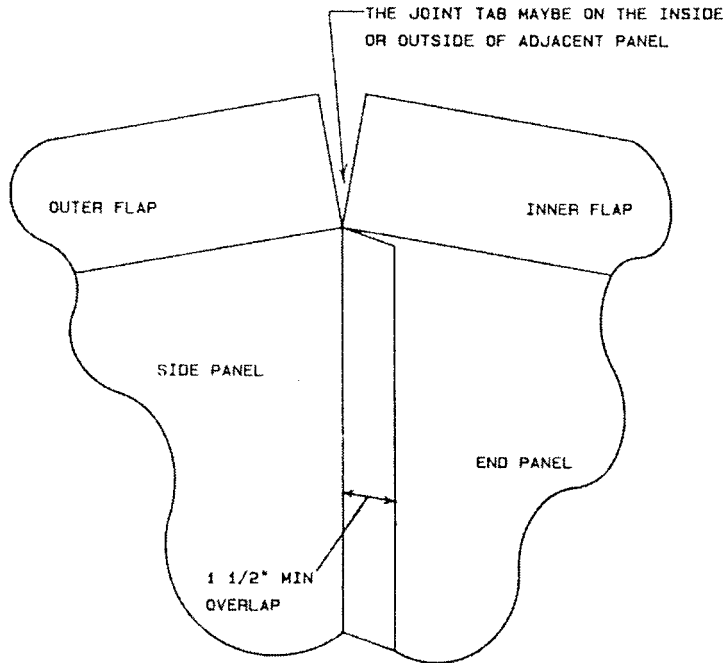

**NOTE:** The joint tab may be integral with end or side panels.

FIG. 2 Box, Fiberboard; Detail of Manufacturer's Joint Construction for Class Weather Resistant and WWVR Boxes

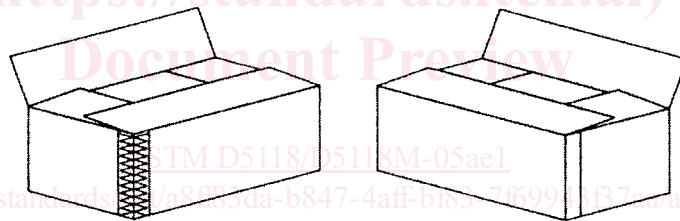

**TAPED**  
See 6.1.2.4.  
Refer to 6.4.1.1(2) & 6.4.2.1(2)  
for Manufacturer's Joint  
Information

**STITCHED (INSIDE OR OUT)**  
See 6.1.2.3.  
Refer to 6.4.1.1(1) & 6.4.2.1(1)  
for Manufacturer's Joint  
Information

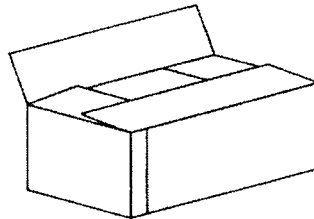

**GLUED (INSIDE OR OUT)**  
See 6.1.2.1 & 6.1.2.2.  
Refer to 6.4.1.1 for Manufacturer's Joint Information

FIG. 3 Box, Fiberboard; Details of Manufacturer's Joint Types

6.1.1 Fiberboard shall conform to type, class, variety, and grade of Specification **D4727/D4727M** unless otherwise speci-

fied. Flute structure shall be as specified in Specification **D4727/D4727M** (see 8.1.2).

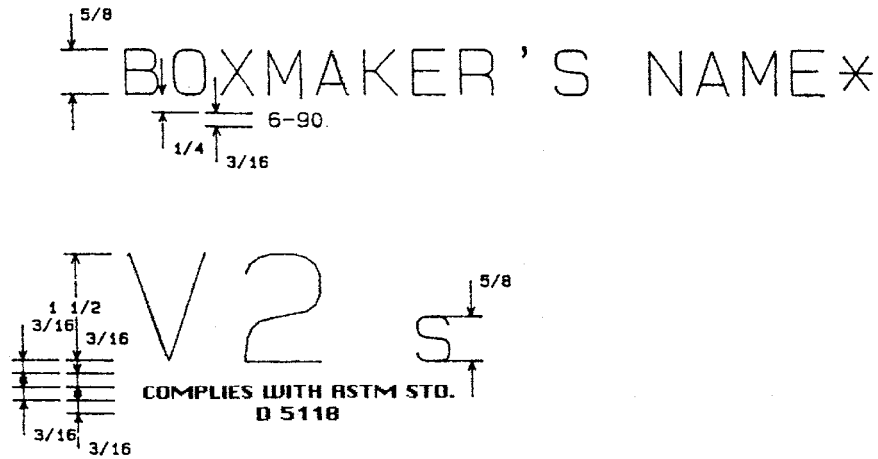

NOTE 1—Dimension and cube can be boxmaker's certificate, round or rectangular as applicable and may be located on the box where it is customarily placed.

NOTE 2—Dimensions and cube other than specified in MIL-STD-129 shall be printed only on government procured boxes.

FIG. 4 Compliance Marking for Class Weather-Resistant and WWVR Boxes

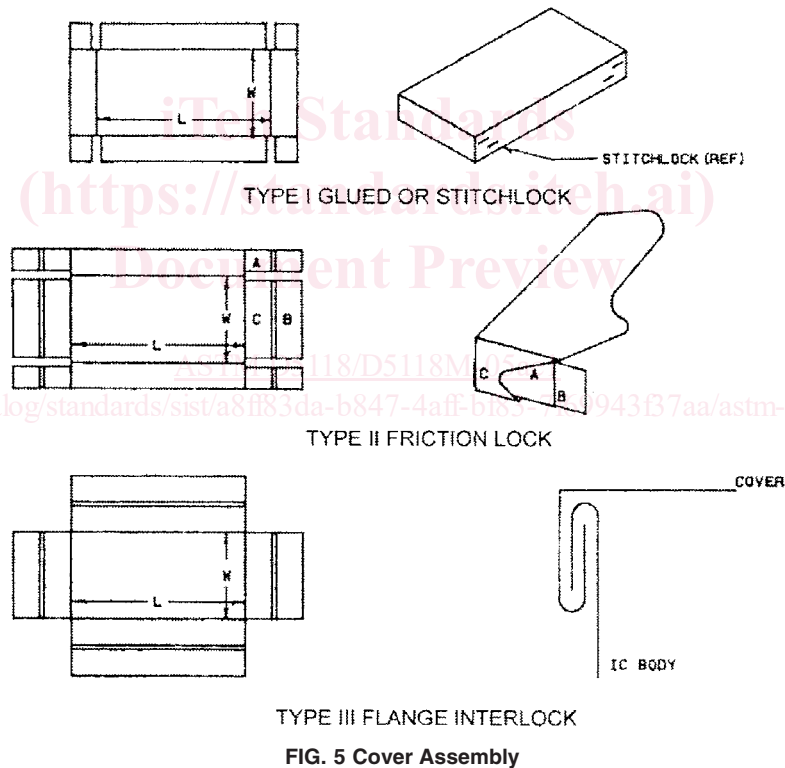

TYPE III FLANGE INTERLOCK

FIG. 5 Cover Assembly

6.1.2 Manufacturer's joints shall be secured by one of the following materials: (The joint is that seam of a box where the ends of the box blank are joined.)

6.1.2.1 *Cold adhesive* shall conform to CID-A-A-59692 and as specified herein. When boxes are used for packaging or packing food and the adhesive used may contact or be in proximity to the food, the adhesive shall comply with the Federal Food, Drug and Cosmetic Act and regulations promulgated thereunder.

6.1.2.2 *Hot melt adhesives* can be used when gross weight does not exceed 65 lb [30 kg], by overlapping the sides of box

forming the joint not less than 1 1/4 in. [32 mm] and by firmly gluing this joint with hot melt adhesive consisting of 100 % solids contents of thermal-plastic materials, which will maintain bond at temperatures ranging from -20°F [-29°C] to +165°F [+74°C] above zero.

6.1.2.3 *Metal fasteners* shall be commercially preformed staples or staples formed from commercial steel stitching wire. All metal fasteners shall have commercially applied coating of zinc or copper wash.

6.1.2.4 *Manufacturer's joint tapes* shall be of the following constructions:

SLEEVE JOINTS MAY BE  
STITCHED, STAPLED OR GLUED.  
(SEE 6.2.2.1 & 6.4.1.2)

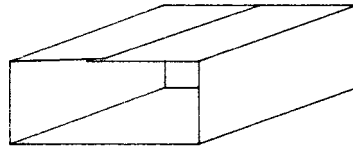

MFG JOINT IN CENTER

SEE FIG 1A FOR STITCHING  
PATTERN (WHEN SPECIFIED)

OVERLAP ON BOTH  
STYLES SHALL BE  
1 1/2" MINIMUM

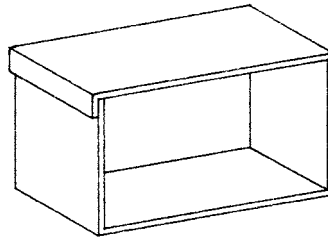

SLEEVES MUST BE A

CLOSE FIT ON BOX

(SEE 6.2.2.1)

FIG. 6 Box, Fiberboard; SL—Sleeve

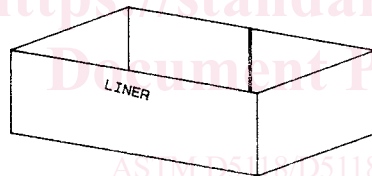

LINER PARTIALLY  
INSERTED INTO BOX

FIG. 7 Box, Fiberboard; L—Liner

(1) For boxes not exceeding 65 lb [30 kg] gross weight sealing strips must not be less than 2 in. [51 mm] wide, and must comply with one of the following requirements:

(a) Two thicknesses of sulphate paper, total basis weight not less than 80 lb [130 g/m<sup>2</sup>] combined with a water-resistant compound and reinforced with not less than double strand nylon fiber not less than 210 denier forming a pattern with strands not more than 1/2 in. [13 mm] apart.

(b) Cloth having crosswise (filler) threads having a minimum tearing strength of 40 Elemendorf units. Inside and

outside strips of sulphate paper not less than 2 in. [51 mm] wide; outside strip having a basis weight of not less than 60 lb [100 g/m<sup>2</sup>] having a bursting strength of not less than 60 psi [414 kPa]; inside strip having a basis weight not less than 40 lb [65 g/m<sup>2</sup>], and a bursting strength of not less than 40 psi [275 kPa].

(2) For boxes exceeding 65 lb [30 kg] gross weight, sealing strips must be not less than 3 in. [76 mm] wide, unless otherwise provided, and must comply with one of the following requirements:

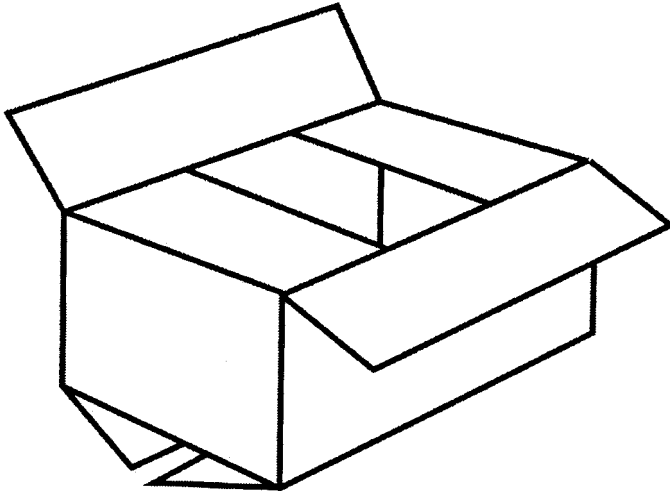

FIG. 8 Box, Fiberboard; RSC—Regular Slotted Box (0201)

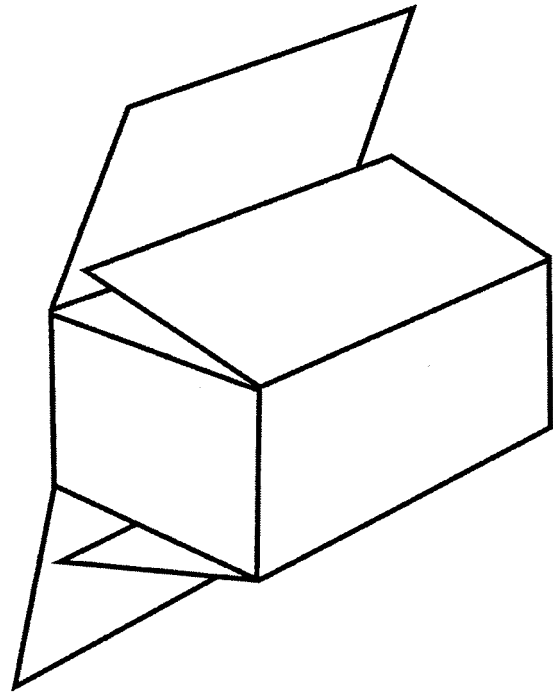

FIG. 10 Box, Fiberboard; FOL—Full Overlap Slotted Box (0203)

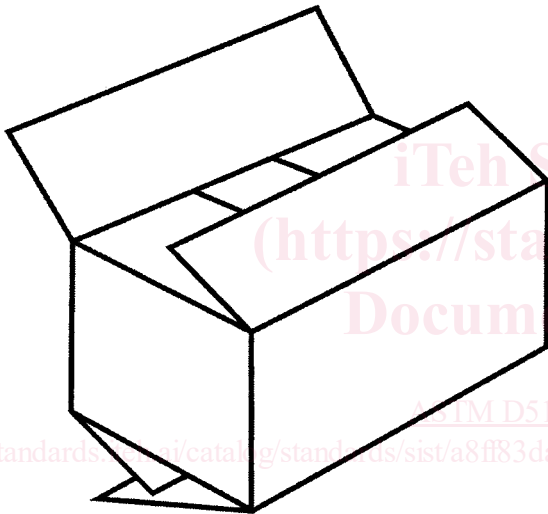

FIG. 9 Box, Fiberboard; OSC—Overlap Slotted Box (0202)

(a) One thickness of sulphate paper, the fibers of which are integrally bonded and reinforced with rubber, basis weight not less than 175 lb [285 g/m<sup>2</sup>], embossed and varnished. Two thicknesses of sulphate paper, total basis weight not less than 80 lb [130 g/m<sup>2</sup>], reinforced in the cross direction with alternating bands of 840 denier and 420 denier nylon, not less than 4 bands every 2 in. [51 mm]. One thickness of sulphate paper having a basis weight not less than 70 lb [114 g/m<sup>2</sup>] reinforced in the cross direction with alternating bands of 840 denier and 420 denier nylon, not less than 4 bands every 2 in. [51 mm], nylon bands firmly adhered to the surface of the paper by means of a water-resistant compound.

NOTE 1—Kraft tape basis weights are calculated as a ream weight of 500 sheets of 24 in. [610 mm] by 36 in. [915 mm] paper. The base stocks are 90 lb [41 kg], 120 lb [55 kg] or 140 lb [64 kg] kraft ream weight. These convert to 30 lb/1000 ft<sup>2</sup> [150 g/m<sup>2</sup>], 40 lb/1000 ft<sup>2</sup> [195 g/m<sup>2</sup>], and 47 lb/1000 ft<sup>2</sup> [230 g/m<sup>2</sup>] kraft liner board equivalents.

(b) Two thicknesses of sulphate paper, total basis weight not less than 80 lb [130 g/m<sup>2</sup>] combined with a water-resistant

compound and with reinforcing as follows:

—With glass, rayon, or glass and rayon fibers combined, running crosswise of tape not more than 3/8 in. [10 mm] apart, the rayon fibers to be not less than 1100 denier.

—With glass fibers in a diamond pattern the sides of which, parallel to each other, are formed by a cluster of yarn not less than two per inch as measured in the machine direction. Each cluster shall be formed of at least two 150-1/0 threads or the equivalent in weight of 75-1/0 yarn.

(c) Two thicknesses of sulphate paper, one 30 lb [50 g/m<sup>2</sup>] basis weight and the other 60 lb [98 g/m<sup>2</sup>] basis weight reinforced with cotton or linen fibers.

(d) Two or more thicknesses of sulphate paper, total basis weight not less than 150 lb [244 g/m<sup>2</sup>] and having a bursting strength of not less than 150 psi [1034 kPa], all plies firmly glued together not less than 1/4 in. [6 mm] wide along both edges. Cloth having crosswise (filled) threads having a minimum tearing strength of 70 Elemendorf units. Inside and outside strips of sulphate paper not less than 2 in. [50.0 mm] wide, each having a basis weight not less than 90 lb [147 g/m<sup>2</sup>], and having a bursting strength of not less than 90 psi [621 kPa].

6.2 Boxes shall be designed for type, class, variety, and grade as set forth in Specification D4727/D4727M, Tables 1 and 2, and styles specified herein (see 5.1, 5.2 and 6.2.1).

6.2.1 Style:

6.2.1.1 The style of box or folder shall be as specified (see 8.1.3). The location of the openings shall be determined by the specified dimensions, which shall always be furnished in the order of length, width, and depth (see 6.3 and Fig. 1 and Fig. 15).

6.2.1.2 Regular Slotted (RSC/0201)—This box shall meet the requirements of Fig. 8. The box shall be scored and slotted