



SLOVENSKI STANDARD

SIST ISO 789-3:1997

01-maj-1997

Kmetijski traktorji - Preskusne metode - 3. del: Premer obračalnega kroga in kroga, ki ga opiše skrajna zunanja točka traktorja

Agricultural tractors -- Test procedures -- Part 3: Turning and clearance diameters

Tracteurs agricoles -- Méthodes d'essai -- Partie 3: Diamètres de braquage et de dégagement

ITeH STANDARD PREVIEW
(standards.iteh.ai)

Ta slovenski standard je istoveten z: ^{SIST ISO 789-3:1997} **ISO 789-3:1993**
<https://standards.iteh.ai/catalog/standards/sist/60572188-9580-43e1-9f9f-3bad0ca9a61a/sist-iso-789-3-1997>

ICS:

65.060.10 Kmetijski traktorji in prikolice Agricultural tractors and
trailed vehicles

SIST ISO 789-3:1997

en

iTeh STANDARD PREVIEW
(standards.iteh.ai)

[SIST ISO 789-3:1997](#)

<https://standards.iteh.ai/catalog/standards/sist/60572188-9580-43e1-9f9f-3bad0ca9a61a/sist-iso-789-3-1997>

INTERNATIONAL
STANDARD

ISO
789-3

Second edition
1993-08-15

Agricultural tractors — Test procedures —

Part 3:

Turning and clearance diameters

iTeh STANDARD PREVIEW

(standards.iteh.ai)
Tracteurs agricoles — Méthodes d'essai —

Partie 3: Diamètres de braquage et de dégagement

SIST ISO 789-3:1997

<https://standards.iteh.ai/catalog/standards/sist/60572188-9580-43e1-9f9f-3bad0ca9a61a/sist-iso-789-3-1997>



Reference number
ISO 789-3:1993(E)

Foreword

ISO (the International Organization for Standardization) is a worldwide federation of national standards bodies (ISO member bodies). The work of preparing International Standards is normally carried out through ISO technical committees. Each member body interested in a subject for which a technical committee has been established has the right to be represented on that committee. International organizations, governmental and non-governmental, in liaison with ISO, also take part in the work. ISO collaborates closely with the International Electrotechnical Commission (IEC) on all matters of electrotechnical standardization.

Draft International Standards adopted by the technical committees are circulated to the member bodies for voting. Publication as an International Standard requires approval by at least 75 % of the member bodies casting a vote.

International Standard ISO 789-3 was prepared by Technical Committee ISO/TC 23, *Tractors and machinery for agriculture and forestry*, Subcommittee SC 2, *Common tests*.

ISO 789 consists of the following parts, under the general title *Agricultural tractors — Test procedures*:

- Part 1: *Power tests for power take-off*
- Part 2: *Rear three-point linkage lifting capacity*
- Part 3: *Turning and clearance diameters*
- Part 4: *Measurement of exhaust smoke*
- Part 5: *Partial power PTO — Non-mechanically transmitted power*
- Part 6: *Centre of gravity*
- Part 7: *Axle power determination*
- Part 8: *Engine air cleaner*
- Part 9: *Power tests for drawbar*

© ISO 1993

All rights reserved. No part of this publication may be reproduced or utilized in any form or by any means, electronic or mechanical, including photocopying and microfilm, without permission in writing from the publisher.

International Organization for Standardization
Case Postale 56 • CH-1211 Genève 20 • Switzerland

Printed in Switzerland

— *Part 10: Measurement of hydraulic power — Tractor/implement interface*

— *Part 11: Steering capability — Wheeled tractors*

Annex A forms an integral part of this part of ISO 789.

iTeh STANDARD PREVIEW **(standards.iteh.ai)**

[SIST ISO 789-3:1997](https://standards.iteh.ai/catalog/standards/sist/60572188-9580-43e1-9f9f-3bad0ca9a61a/sist-iso-789-3-1997)

<https://standards.iteh.ai/catalog/standards/sist/60572188-9580-43e1-9f9f-3bad0ca9a61a/sist-iso-789-3-1997>

iTeh STANDARD PREVIEW
(standards.iteh.ai)

This page intentionally left blank

[SIST ISO 789-3:1997](#)

<https://standards.iteh.ai/catalog/standards/sist/60572188-9580-43e1-9f9f-3bad0ca9a61a/sist-iso-789-3-1997>

Agricultural tractors — Test procedures —

Part 3: Turning and clearance diameters

1 Scope

This part of ISO 789 specifies a method of determining the turning and clearance diameters of wheeled agricultural tractors.

It applies to wheeled agricultural tractors having at least two axles fitted with pneumatic tyres.

2 Definitions

For the purposes of this part of ISO 789, the following definitions apply.

2.1 agricultural tractor: Self-propelled wheeled machine having at least two axles, particularly designed to pull, push, carry and operate implements used for agricultural work (including forestry work), which may be provided with a detachable loading platform.

2.2 track (tread) of wheeled tractor: Distance at ground level between two vertical planes passing through the centreline of ground contact of the tyres parallel to the median plane of the tractor with the wheels in the straight ahead position. (See figure 1.)

In the case of dual wheels it is the distance at ground level between two planes passing through the centreline of the dual wheels.

2.3 wheelbase: Distance at ground level between two vertical planes passing through the centres of the front wheels and the rear wheels with tractor and wheels in the same straight ahead position. (See figure 1.)

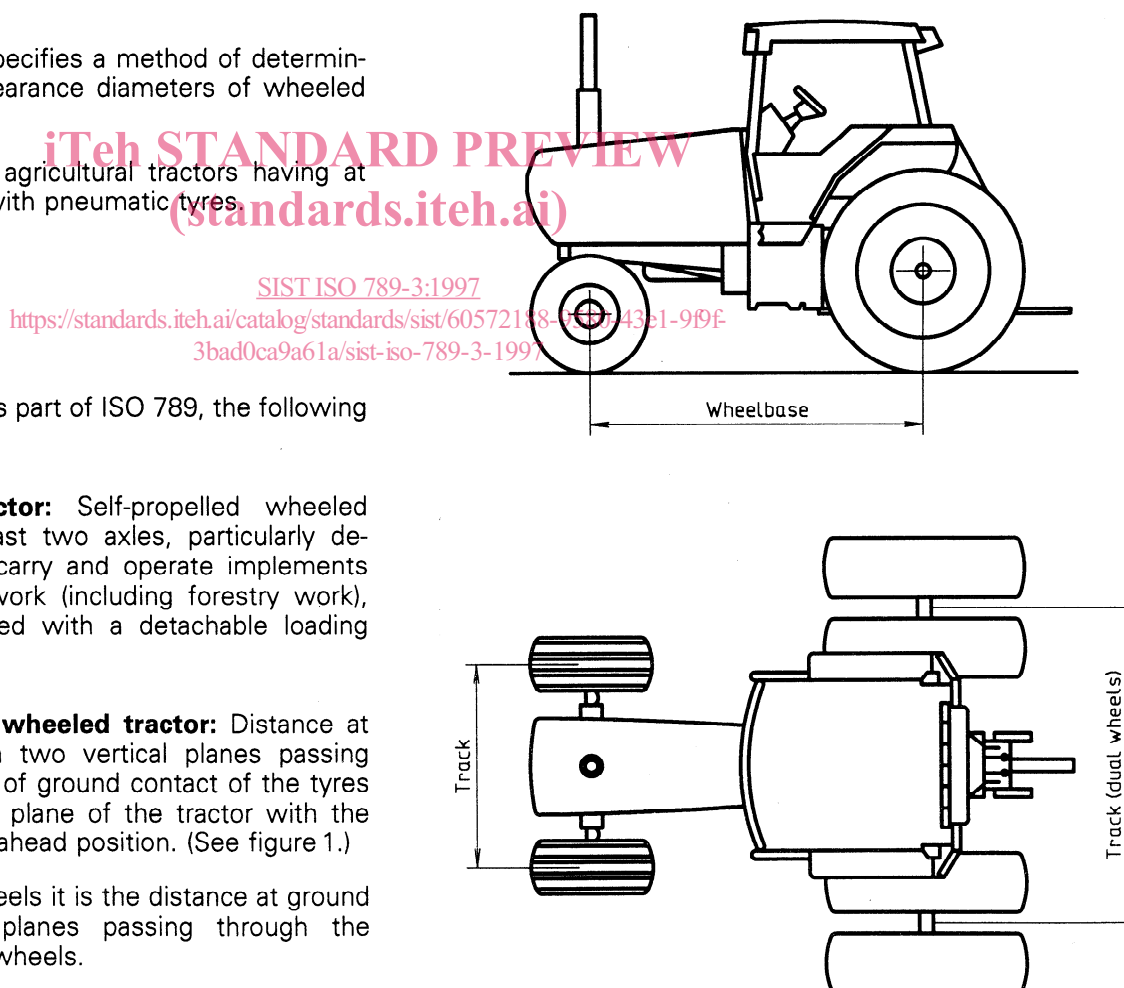

Figure 1 — Track (tread) and wheelbase of wheeled tractor

ISO 789-3:1993(E)

In the case of a tractor equipped with a rear tandem, it is the distance between two vertical planes passing through the centres of the front wheel and the vertical plane midway between the wheel centres of the two axles of the tandem.

2.4 turning diameter: Diameter of the circular path described by the centre of tyre contact with the surface of the test site of the wheel describing the largest circle when the tractor is executing its sharpest practicable turn under the test conditions described in clause 5. (See figure 2.)

2.5 clearance diameter: Diameter of the smallest circle which will enclose the outermost points of projection of the tractor and its equipment while executing its sharpest practicable turn. (See figure 2.)

3 Apparatus

3.1 Tape measure, of length greater than the turning and clearance diameters to be measured, having a tolerance within $\pm 0,5\%$.

3.2 Plumb-line, if required, for measuring clearance diameters.

4 General requirements

4.1 Test area

The test area shall be a compacted or paved dry surface affording good tyre adhesion, capable of displaying legible markings, and resistant to defacement by turning machines. The test surface shall be visually flat, with no more than 3 % grade in any direction.

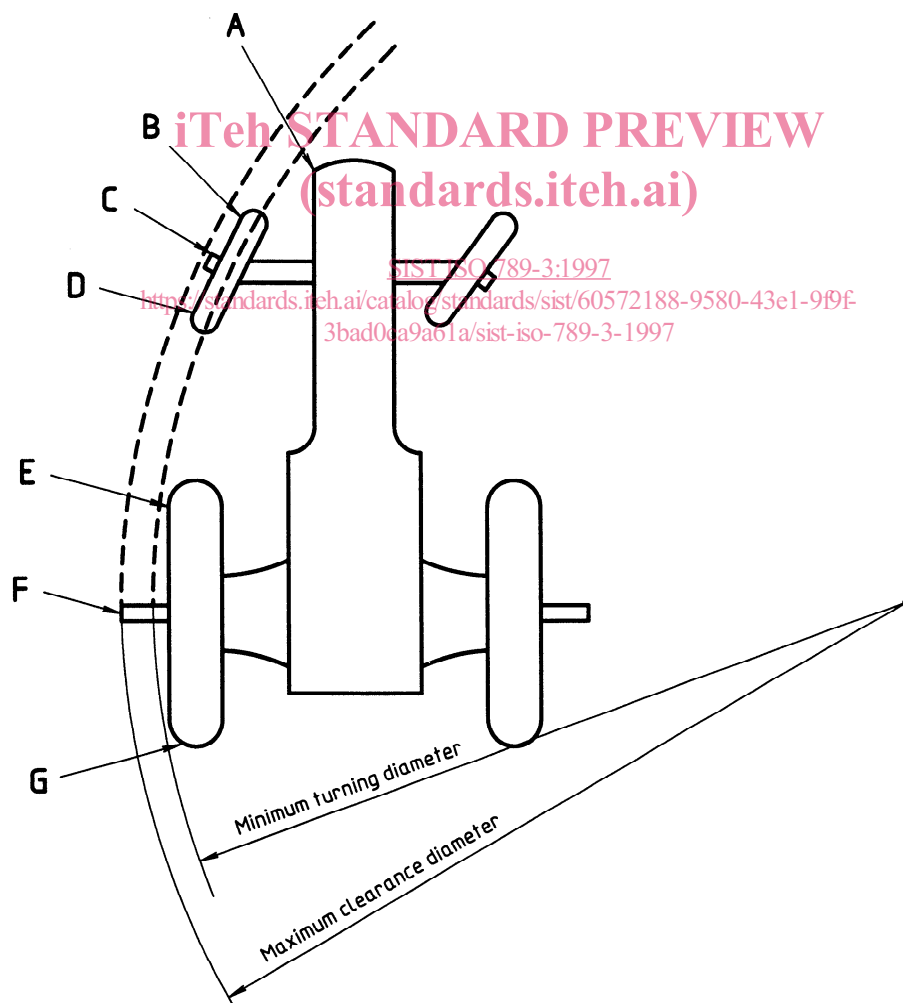

Figure 2 — Tractor turning configurations

4.2 Tractor test requirements

4.2.1 Tyre and wheel equipment

The tractor to be tested shall be in its operating state, and the attachments with which it is equipped and their positions shall be noted.

The tyre, wheel and fender equipment shall be that commonly used in the country for which the tractor is intended, i.e. as specified by the manufacturer, and shall be stated in the test report. Generally dual wheeled tractors or tractors with added ballast should not be tested unless it is the only specification presented by the manufacturer. Tyre pressures, tractor ballast and use of duals on front or rear shall be recorded in the test report. If steering and/or axle oscillation stops and fenders are part of standard equipment then these shall be positioned according to the manufacturer's instructions.

4.2.2 Track (tread) setting

A track (tread) setting of $1\ 500\ \text{mm} \pm 25\ \text{mm}$ shall be used. If this is not possible, the nearest setting specified by the manufacturer shall be used. Additional measurement may be made at other track settings specified by the manufacturer. Front and rear track settings shall be as nearly as possible the same and shall be recorded.

4.2.3 Other settings

Tractors which have all wheels steerable, or which incorporate devices for disconnecting either or both axles, shall be tested in each operating condition in which the tractor is intended to be used.

Results shall be recorded for each operating condition.

Tractors which have more than one powered axle, and which have devices for disconnecting the power to any of the axles, shall be tested in each operating condition in which the tractor is intended to be used.

Results shall be recorded for each operating condition.

5 Procedure

5.1 Right-hand turn, without brakes

5.1.1 Drive the tractor slowly forward while making its sharpest possible right-hand turn, that is, with the steering kept on full right-hand lock, at a speed not exceeding 2 km/h for at least one complete turn, until it is established that the minimum turning circle is being described.

5.1.2 Continue to drive the tractor slowly forward on the same lock for a further complete turn, at a speed not exceeding 2 km/h. At short regular intervals around the turn, mark on the ground those points coinciding with the centre of the tyre-to-ground contact area of the outermost wheel. Make the marks immediately behind this contact area and determine the position of each mark by visually projecting vertically downwards from the centre of the tyre tread width at points on the tyre circumference situated as close as possible to the ground.

The marking may be done with or without stopping the tractor. The broken circle formed by the marks on the ground is the turning circle.

5.1.3 During the turn described in 5.1.2, stop the tractor and drop a plumb-line to the ground from the outermost point of the tractor (that is from the point of the tractor describing the largest circle). Clearly mark the point on the ground beneath the plumb-line: this point lies on the tractor clearance circle.

5.1.4 Measure the diameter of the turning circle (see 5.1.2) at a minimum of three places spaced approximately equally around the circle. Calculate the average value of the diameter measured and report it as the "minimum turning diameter, right-hand, without brakes". Alternatively, the diameter of the turning circle may be calculated as shown in figure 3 and reported in the same way.

5.1.5 Measure and record the radial distance between the point on the tractor clearance circle (see 5.1.3) and the circumference of the tractor turning circle (see 5.1.2). Add twice this dimension to the minimum turning diameter and report the result as the "minimum clearance diameter, right-hand, without brakes".

5.2 Left-hand turn, without brakes

Repeat the procedures described in 5.1 with the tractor driven forward while making its sharpest possible left-hand turn, that is, with the steering kept on full left-hand lock. Report the results as the "minimum turning/clearance diameter, left-hand, without brakes".

5.3 Right-hand turn, with brakes

Where applicable, repeat the procedure described in 5.1 with the inside non-steered wheel brake applied with a pedal effort sufficient to lock the wheel, subject to a maximum of 60 daN.

Report the results as the "minimum turning/clearance diameter, right-hand, with brakes".