



Designation: D6511 – 06

Standard Test Methods for Solvent Bearing Bituminous Compounds¹

This standard is issued under the fixed designation D6511; the number immediately following the designation indicates the year of original adoption or, in the case of revision, the year of last revision. A number in parentheses indicates the year of last reapproval. A superscript epsilon (ϵ) indicates an editorial change since the last revision or reapproval.

1. Scope

1.1 These test methods cover procedures for sampling and testing solvent bearing bituminous compounds for use in roofing and waterproofing.

1.2 The test methods appear in the following order:

| | Section |
|---|---------|
| Sampling | 4 |
| Uniformity | 5 |
| Weight per gallon | 6 |
| Nonvolatile content | 7 |
| Solubility | 8 |
| Ash content | 9 |
| Water content | 10 |
| Consistency | 11 |
| Behavior at 60°C (140°F) | 12 |
| Pliability at -0°C (32°F) | 13 |
| Aluminum content | 14 |
| Reflectance of aluminum roof coatings | 15 |
| Strength of laps of rolled roofing adhered with roof adhesive | 16 |
| Adhesion to damp, wet, or underwater surfaces | 17 |
| Mineral stabilizers and bitumen | 18 |
| Mineral matter | 19 |
| Volatile organic content | 20 |

1.3 The values stated in SI units are to be regarded as the standard. The values given in parentheses are for information only.

1.4 *This standard does not purport to address all of the safety concerns, if any, associated with its use. It is the responsibility of the user of this standard to establish appropriate safety and health practices and determine the applicability of regulatory limitations prior to use.*

2. Referenced Documents

2.1 *ASTM Standards:*²

- [C670 Practice for Preparing Precision and Bias Statements for Test Methods for Construction Materials](#)
- [D4 Test Method for Bitumen Content](#)
- [D88 Test Method for Saybolt Viscosity](#)

¹ These test methods are under the jurisdiction of ASTM Committee D08 on Roofing and Waterproofing and are the direct responsibility of Subcommittee D08.05 on Solvent-Bearing Bituminous Compounds for Roofing and Waterproofing.

Current edition approved Dec. 1, 2006. Published January 2007. Originally approved in 2000. Last previous edition approved in 2000 as D6511 – 00. DOI: 10.1520/D6511-06.

² For referenced ASTM standards, visit the ASTM website, www.astm.org, or contact ASTM Customer Service at service@astm.org. For *Annual Book of ASTM Standards* volume information, refer to the standard's Document Summary page on the ASTM website.

[D95 Test Method for Water in Petroleum Products and Bituminous Materials by Distillation](#)

[D140 Practice for Sampling Bituminous Materials](#)

[D146 Test Methods for Sampling and Testing Bitumen-Saturated Felts and Woven Fabrics for Roofing and Waterproofing](#)

[D224 Specification for Smooth-Surfaced Asphalt Roll Roofing \(Organic Felt\)³](#)

[D249 Specification for Asphalt Roll Roofing \(Organic Felt\) Surfaced with Mineral Granules³](#)

[D562 Test Method for Consistency of Paints Measuring Krebs Unit \(KU\) Viscosity Using a Stormer-Type Viscometer](#)

[D1475 Test Method For Density of Liquid Coatings, Inks, and Related Products](#)

[D2369 Test Method for Volatile Content of Coatings](#)

[D2824 Specification for Aluminum-Pigmented Asphalt Roof Coatings, Nonfibered, Asbestos Fibered, and Fibered without Asbestos](#)

[D4017 Test Method for Water in Paints and Paint Materials by Karl Fischer Method](#)

[E1 Specification for ASTM Liquid-in-Glass Thermometers](#)

[E145 Specification for Gravity-Convection and Forced-Ventilation Ovens](#)

[E200 Practice for Preparation, Standardization, and Storage of Standard and Reagent Solutions for Chemical Analysis](#)

3. Significance and Use

3.1 These tests are useful in sampling and testing solvent bearing bituminous compounds to establish uniformity of shipments.

4. Sampling

4.1 Determine the number of containers sampled to represent a shipment in accordance with Practice [D140](#).

4.2 Open the original containers and examine them for uniformity of contents. Record the degree of separation, if any, into portions of appreciably different consistency, such as thick or thin layers, sedimentation or coagulation, etc. Also, note any difficulty encountered in stirring to a uniform condition.

4.3 Take the samples for laboratory examination from the original containers immediately after stirring to a uniform

³ Withdrawn. The last approved version of this historical standard is referenced on www.astm.org.

condition. Restir individual or combined samples immediately before taking out portions for tests.

5. Uniformity

5.1 *Procedure*—Examine the contents of a full container of not less than 1 L or 1 qt in volume that has stood undisturbed for 72 h.

5.2 *Report*—Make a notation of any separation or settlement of suspended matter that cannot be overcome by moderate agitation.

6. Weight-per-Gallon/Specific Gravity

6.1 Apparatus:

6.1.1 *Weight-per-Gallon Cup*, with lid, stainless steel, calibrated to contain 83.3 g of water at $25 \pm 0.5^\circ\text{C}$ ($77 \pm 1^\circ\text{F}$).

6.1.2 *Balance*, accurate to 0.01 g.

6.1.3 *Water Bath*, constant temperature, maintained at $25 \pm 0.5^\circ\text{C}$ ($77 \pm 1^\circ\text{F}$).

6.2 Procedure:

6.2.1 Stir the sample, and place in the 25°C (77°F) water bath until the sample temperature reaches $25 \pm 0.5^\circ\text{C}$ ($77 \pm 1^\circ\text{F}$). Time required for temperature equilibration depends on sample size and configuration.

6.2.2 Condition cup and lid to $25 \pm 0.5^\circ\text{C}$ ($77 \pm 1^\circ\text{F}$). Weigh the weight-per-gallon cup with lid to the nearest 0.01 g and record as tare weight.

6.2.3 Remove the sample from the bath, and stir until homogeneous. Avoid trapping air in the sample during stirring.

6.2.4 Carefully fill the weight-per-gallon cup with the sample avoiding the entrapment of air. Jar or vibrate the cup until no further change in volume occurs.

6.2.5 Immediately place the lid on the weight-per-gallon cup and remove, with a clean rag or paper, the excess sample oozing through the orifice in the lid.

6.2.6 When the lid is placed on tightly, clean the weight-per-gallon cup carefully, weigh on the balance to the nearest 0.01 g, and record as weight of sample and tare.

6.3 Calculations:

6.3.1 Calculate the weight-per-gallon of the sample as follows:

$$D = (B - A)/10 \quad (1)$$

where:

A = tare weight of weight-per-gallon cup, g,

B = weight of sample and tare g, and

D = weight-per-gallon of sample, lb/gal. To convert units to kg/m^3 , multiply D by 119.83.

6.3.2 Calculate the specific gravity of the sample as follows:

$$SG = D/8.33 \quad (2)$$

where:

SG = specific gravity,

D = weight-per-gallon of sample calculation from 6.3.1, and

8.33 = weight-per-gallon of water at $25 \pm 0.5^\circ\text{C}$ ($77 \pm 1^\circ\text{F}$).

6.4 Report:

6.4.1 Report the weight-per-gallon of the sample in pounds-per-gallon to the nearest 0.1 lb at 25°C (77°F).

6.4.2 Report the specific gravity of the sample to the nearest hundredth at 25°C (77°F).

7. Nonvolatile Content

7.1 Apparatus:

7.1.1 *Metal Dish*, flat-bottom, having a diameter of 65 mm (2.5 in.) with walls 10 mm ($\frac{5}{8}$ in.) high.

7.1.2 *Oven*, forced draft, conforming to Specification E145, Type III B, for asphalt products, or a standard convection oven for coal tar products.

7.1.3 *Balance*, capable of weighing 50 g to within ± 0.01 g.

7.2 *Procedure*—Weigh 10 ± 1.00 g in the tared metal dish to the nearest 0.01 g. Dry the dish and its contents in a forced draft oven at $163 \pm 3^\circ\text{C}$ ($325 \pm 5^\circ\text{F}$) for asphalt products or 105 to 110°C (221 to 230°F) in standard convection oven for coal tar products until the residue shows a loss of not more than 0.05 g on successive hourly weighings (approximately 4 h), after cooling in a desiccator.

7.3 *Calculation*—Calculate the percent nonvolatile content R_f , from the mass of the dry residue and the mass of the original sample, as follows:

$$R_f = (R/S) \times 100 \quad (3)$$

where:

R = mass of dry residue, g, and

S = mass of sample, g.

7.4 *Report*—Record the average of two determinations.

8. Solubility of Residue in Carbon Disulfide or Trichloroethylene

8.1 *Apparatus*—See Test Method D4.

8.2 *Procedure*—Determine the matter soluble in carbon disulfide or trichloroethylene on a representative portion of the nonvolatiles (Section 7), in accordance with Test Method D4.

8.3 *Calculation*—Calculate the percent solubility in carbon disulfide or trichloroethylene S_f from the mass of the residue and the mass of the original sample as follows:

$$S_f = (R/S) \times 100 \quad (4)$$

where:

R = mass of insoluble residue, g, and

S = mass of sample, g.

8.4 *Report*—Percent by weight of the residue that was soluble in the carbon disulfide or trichloroethylene.

9. Ash Content

9.1 Apparatus:

9.1.1 *Porcelain Crucible*, 30-cm³ capacity, or equivalent.

9.1.2 *Balance*, capable of weighing 50 g to within ± 0.01 g.

9.1.3 *Muffle Furnace*, capable of maintaining a temperature of $593 \pm 2.5^\circ\text{C}$ ($1100 \pm 10^\circ\text{F}$).

9.2 *Procedure*—Thoroughly mix the dry residue from the determination of residue by evaporation (store the residue in a desiccator at all times prior to this test) (Section 7) and weigh 3 ± 0.5 g to the nearest 0.01 g in a previously ignited and tared crucible. Incinerate the contents inside a muffle furnace at a temperature of 600°C (1110°F) to constant weight. (**Warning**—This incineration will produce black smoke. This procedure should be carried out under a fume hood.)

9.3 *Calculation*—Calculate the ash thus obtained, A_r , as percent of the residue by evaporation as follows:

$$A_r = (A/S) \times 100 \quad (5)$$

9.4 *Report*—Ash as a percentage of the residue by evaporation.

10. Water Content

10.1 *Apparatus*—See Test Method D95.

10.2 *Procedure*—Determine water content in accordance with Test Method D95.

10.3 *Calculation*—Calculate the water in the sample, as mass percent, as follows:

$$\text{Water, \%} = \frac{V (0.99707)}{W \times 100} \quad (6)$$

where:

V = volume of water in trap (ml), and

W = mass of sample (gm).

Volatile water-soluble material, if present, may be measured as water.

10.4 *Report*—Report as mass percent of the sample.

11. Consistency

11.1 *Asphalt Roof Coatings:*

11.1.1 *Summary of Test Method*—Consistency is determined using the stormer viscometer and the rate of shear reported in terms of the time required for 100 revolutions of the rotor produced by a specified load (compare with Test Method D562).

11.1.2 *Apparatus:*

11.1.2.1 *Standard Stormer Viscometer.*

11.1.2.2 *Water Bath-Test Cup Assembly*, without central baffle or thermometer holder.

11.1.2.3 *Rotor*, propeller-type (see Fig. 1).

11.1.2.4 *Slotted Weights*, and a suitable hanger.

11.1.2.5 *Thermometer*—ASTM stormer viscosity thermometer having a range from 20 to 70°C, and conforming to the requirements for Thermometer 49C as prescribed in Specification E1.

11.1.2.6 *Stop Watch.*

11.1.3 *Preparation of Apparatus:*

11.1.3.1 Place the stormer viscometer on a table or shelf high enough to permit the weight to drop about 1 m (40 in.), or

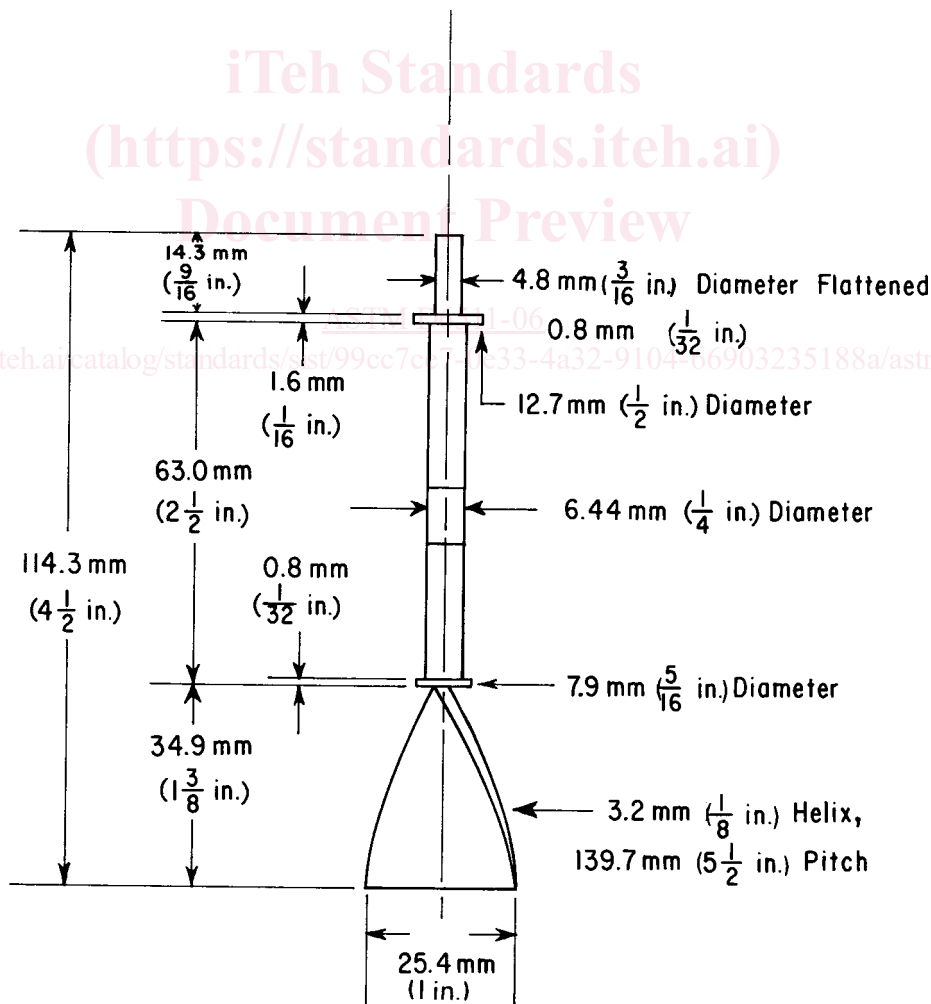

NOTE 1—All dimensions are subject to a tolerance of ± 0.1 mm (± 0.004 in.). Material: nickel-plated brass or stainless steel.

FIG. 1 Propeller-Type Rotor for Use with Stormer Viscometer

sufficient distance to produce about 125 revolutions of the rotor. Insert the shaft of the propellar-type rotor in the chuck as far as it will go and secure it with the set screw.

11.1.3.2 Raise the water bath-test cup assembly until the bottom of the test cup just touches the bottom of the rotor blade; then, lower the assembly 6 mm ($\frac{1}{4}$ in.). Tighten the set screw on the position collar, if available, while the collar is in contact with the bracket and the assembly, and use this setting to position the cup for all test runs. Using the set screws in the rim of the bath holder, adjust the water bath-test cup assembly so that the cup and rotor are visually concentric.

11.1.3.3 For convenience in weight adjustment, attach a slotted metal can cover approximately 50 mm (2 in.) in diameter to the hanger to support the slotted weights required.

11.1.4 Calibration:

11.1.4.1 Use a 94.85 % by weight aqueous glycerin solution as a calibration standard. Determine the initial concentration of reagent grade glycerin by accurately measuring its specific gravity (see [Appendix X1](#)), and then add additional water to make up the desired total of 5.15 % by weight water.

11.1.4.2 Determine the weight on the viscometer cord (approximately 100 g) required to produce 100 revolutions of the rotor in the glycerin calibration standard at $25 \pm 0.2^\circ\text{C}$ in 18.0 ± 0.2 s, this is the standardizing load. Check the calibration periodically, particularly after prolonged use of the instrument, and recalibrate as necessary.

11.1.5 Procedure:

11.1.5.1 Remove the test cup and fill it with the sample to a level that will extend 6 mm ($\frac{1}{4}$ in.) above the top of the rotor blade. Agitate the sample in the cup thoroughly to remove any trapped air bubbles. Place the test cup in the water bath, and then move the assembly up into test position against the preset collar.

11.1.5.2 Add 450 g to the standardizing load determined in [11.1.4.2](#). This will be the test load or driving weight.

11.1.5.3 Adjust the temperature of the sample and the entire test assembly to $25 \pm 0.2^\circ\text{C}$. To expedite reaching equilibrium, raise the driving weight and release the brake to provide agitation. When the water bath test cup, sample, and rotor have all reached $25 \pm 0.2^\circ\text{C}$, remove the thermometer.

11.1.5.4 Raise the driving weight on the cord so that it nearly touches the pulley. With stop watch in hand, release the brake and observe the moving pointer. After 8 to 10 revolutions have been made, time the next 100 revolutions. Take the average of at least three determinations and record as the Stormer consistency in s/100 revolutions. Record the driving weight.

11.1.5.5 Consistencies of up to approximately 100 s/100 revolutions shall be determined directly by timing 100 revolutions. For higher consistencies, when timing 100 revolutions might unduly prolong the test, calculate the time required for 100 revolutions from direct measurement of the time required for no less than 25 revolutions.

11.1.6 *Report*—Time required for 100 revolutions using 450-g test load (driving weight) in addition to the standardizing load.

11.2 Aluminum-Pigmented Asphalt Roof Coatings:

11.2.1 *Apparatus*—Use the apparatus and equipment specified in Test Method [D562](#), Procedure A.

11.2.2 Procedure:

11.2.2.1 *Testing D2824 Type I Coating*—Thoroughly mix the sample and fill a 500-ml (1-pt) container to within 20 mm ($\frac{3}{4}$ in.) of the top. Stir the coating carefully to remove any trapped air bubbles. Maintain the temperature of the sample and the test assembly at $25 \pm 0.2^\circ\text{C}$ ($77 \pm 0.3^\circ\text{F}$), and start the test within 1 h after filling the container. Place the container on the platform of the viscometer so that the paddle-type rotor is immersed just to the mark on its shaft, and turn the rotor through approximately 100 revolutions in 25 to 30 s before starting the test. Then determine the time required for 100 revolutions with a 100-g load in addition to the standardizing load from a running start, that is, permit the rotor to make at least 10 revolutions before timing the next 100.

11.2.2.2 *Testing D2824 Type II or Type III Coating*—Follow the procedure in [11.2.2.1](#), except use the propeller-type rotor (see [Fig. 1](#)) with a 300-g load in addition to the standardizing load.

11.2.3 *Report*—Time required for 100 revolutions using 300-g test load (driving weight) in addition to the standardizing load.

11.3 Viscosity of Asphalt Primer:

11.3.1 *Saybolt Furol Viscosity*—Test Method [D88](#).

12. Behavior at 60°C (140°F)

12.1 Preparation and Apparatus:

12.1.1 For solvent-based roof cement prepare two test specimens by troweling cement through masks centered over two steel panels. The masks shall have openings 75 by 125 mm (3 by 5 in.) and shall be 2.4 mm ($\frac{3}{32}$ in.) $\pm 10\%$ thick. The panels shall be 150 by 150 mm (6 by 6 in.); 30 to 28 gage (0.32 to 0.40 mm) nominal thickness; capable of being bent smoothly and uniformly through 180° over a 25 mm (1 in.) diameter mandrel; and shall be free of oil and scale.

12.1.2 For coating, prepare two test specimens with each base by brushing roof coating on two 150 by 150 mm (6 by 6 in.) steel panels and two pieces of smooth surface asphalt roll roofing, each covered by a 0.8 mm ($\frac{1}{32}$ in.) $\pm 10\%$ thick mask with a 75 by 125-mm (3 by 5-in.) opening in the center. The steel panels shall conform to requirements of [12.1.1](#). The smooth surface asphalt roofing roll shall conform to the requirements of Specification [D224](#).

12.2 Procedure:

12.2.1 Immediately after troweling the cement or brushing the coating on the test panels, remove the mask and embed a thread in each coating across the 3-in. (75-mm) dimension, parallel to and no more than 50 mm (2 in.) from one edge of the coating. Measure the distance of the thread from the edge of each test panel to the nearest 0.8 mm ($\frac{1}{32}$ in.).

12.2.2 Expose the test panels horizontally in a well ventilated area for 60 min at $23 \pm 2^\circ\text{C}$ ($73.4 \pm 3.6^\circ\text{F}$), but not in direct sunlight.

12.2.3 Suspend the panels vertically with the thread closest to the top edge in an oven at $62 \pm 2^\circ\text{C}$ ($140 \pm 3.6^\circ\text{F}$). After 5h, remove the test panels from the oven and examine for any sign of blistering. Then, measure to the nearest 0.8 mm ($\frac{1}{32}$ in.) the distance of the thread from the edge of each panel again to