



Designation: E801 – 06

Standard Practice for Controlling Quality of Radiological Examination of Electronic Devices¹

This standard is issued under the fixed designation E801; the number immediately following the designation indicates the year of original adoption or, in the case of revision, the year of last revision. A number in parentheses indicates the year of last reapproval. A superscript epsilon (ϵ) indicates an editorial change since the last revision or reapproval.

This standard has been approved for use by agencies of the Department of Defense.

1. Scope

1.1 This practice relates to the radiological examination of electronic devices for internal discontinuities, extraneous material, missing components, crimped or broken wires, and defective solder joints in cavities, in the encapsulating materials, or the boards. Requirements expressed in this practice are intended to control the quality and repeatability of the radiological images and are not intended for controlling the acceptability or quality of the electronic devices imaged.

NOTE 1—Refer to the following publications for pertinent information on methodology and safety and protection: Guides E94 and E1000, and “General Safety Standard for Installation Using Non-Medical X Ray and Sealed Gamma Ray Sources, Energies Up to 10 MeV Equipment Design and Use,” *Handbook No. 114*.²

1.2 If a nondestructive testing agency as described in Practice E543 is used to perform the examination, the testing agency should meet the requirements of Practice E543.

1.3 *This standard does not purport to address all of the safety concerns, if any, associated with its use. It is the responsibility of the user of this standard to establish appropriate safety and health practices and determine the applicability of regulatory limitations prior to use.*

2. Referenced Documents

2.1 ASTM Standards:³

E94 Guide for Radiographic Examination

E543 Specification for Agencies Performing Nondestructive Testing

E1000 Guide for Radioscopy

E1255 Practice for Radioscopy

¹ This practice is under the jurisdiction of ASTM Committee E07 on Nondestructive Testing and is the direct responsibility of Subcommittee E07.01 on Radiology (X and Gamma) Method.

Current edition approved Dec. 1, 2006. Published January 2007. Originally approved in 1981. Last previous edition approved in 2001 as E801 - 01. DOI: 10.1520/E0801-06.

² Available from National Institute of Standards and Technology (NIST), 100 Bureau Dr., Stop 1070, Gaithersburg, MD 20899-1070, <http://www.nist.gov>.

³ For referenced ASTM standards, visit the ASTM website, www.astm.org, or contact ASTM Customer Service at service@astm.org. For *Annual Book of ASTM Standards* volume information, refer to the standard's Document Summary page on the ASTM website.

E1316 Terminology for Nondestructive Examinations

3. Terminology

3.1 *Definitions*—Refer to Terminology E1316, Section D.

4. Direction of Radiation

4.1 When not otherwise specified, the direction of the central beam of radiation shall be as perpendicular ($\pm 5\%$) as possible to the surface of the film or detector.

5. Image Quality Indicators (IQI's)

5.1 The quality of all levels of radiological examination shall be determined by IQI's conforming to the following specifications:

5.1.1 The IQI's shall be fabricated of clear acrylic plastic with steel covers, lead spheres, gold or tungsten wires, and lead numbers. The steel covers serve as shims.

5.1.1.1 The IQI's shall conform to the requirements of Fig. 1.

5.1.1.2 The IQI's shall be permanently identified with the appropriate IQI number as shown in Fig. 1. The number shall be affixed by mounting a 0.125-in. (3.18-mm) tall lead number on the flat bottom of a 0.250-in. (6.35-mm) diameter hole. The identification number shall be located as shown in Fig. 1 and shall be of sufficient contrast to be clearly discernible in the radiological image.

5.1.1.3 Each semiconductor IQI will have a serial number permanently etched or engraved on it. Each serial number will be traceable to the calibration image supplied by the manufacturer. The manufacturer shall radiograph the IQI with lead markers identifying the serial number. See Fig. 2.

6. Application of the Image Quality Indicator (IQI)

6.1 The application of the IQI's shall be made in such a manner as to simulate as closely as possible the device being examined. To accomplish this objective, a set of eight IQI's is provided. These provide a range of cover thickness (of steel shim stock) that is radiologically equivalent to the range of devices from glass diodes or plastic-encapsulated circuits (number one) to large power or hybrid circuit devices (number eight). Wire size increases with shim stock thickness because

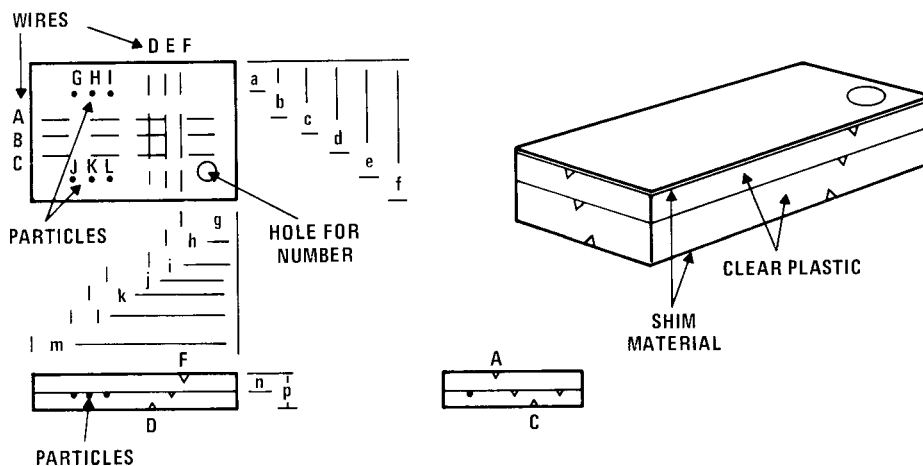

FIG. 1 Image Quality Indicator for Electron Devices

Dimensions, in. (mm)					
a.	0.187 (4.750)	f.	1.00 (25.40)	k.	1.125 (28.575)
b.	0.375 (9.525)	g.	0.375 (9.525)	l.	1.313 (33.350)
c.	0.500 (12.700)	h.	0.500 (12.700)	m.	1.50 (38.10)
d.	0.625 (15.875)	i.	0.625 (15.875)	n.	0.125 (3.175)
e.	0.813 (20.650)	j.	0.938 (23.825)	p.	0.250 (6.350)

Particle Diameter, in. (mm)	
G.	0.015(0.381)
H.	0.010(0.254)
I.	0.008(0.203)
J.	0.006(0.152)
K.	0.004(0.102)
L.	0.002(0.051)

Shim and Wire Specifications

IQI Number	Shim Thickness, in. (mm)	Wire Diameters, in. (mm)					
		A	B	C	D	E	F
1	0 0	0.002 (0.051)	0.001 (0.025)	0.0005 (0.0127)	0.0005 (0.0127)	0.001 (0.025)	0.002 (0.051)
2	0.002 (0.051)	0.002 (0.051)	0.001 (0.025)	0.0005 (0.0127)	0.0005 (0.0127)	0.001 (0.025)	0.002 (0.051)
3	0.005 (0.127)	0.002 (0.051)	0.001 (0.025)	0.0005 (0.0127)	0.0005 (0.0127)	0.001 (0.025)	0.002 (0.051)
4	0.007 0.178	0.002 (0.051)	0.001 (0.025)	0.0005 (0.0127)	0.0005 (0.0127)	0.001 (0.025)	0.002 (0.051)
5	0.010 (0.254)	0.003 (0.076)	0.002 (0.051)	0.001 (0.025)	0.001 (0.025)	0.002 (0.051)	0.003 (0.076)
6	0.015 (0.381)	0.003 (0.076)	0.002 (0.051)	0.001 (0.025)	0.001 (0.025)	0.002 (0.051)	0.003 (0.076)
7	0.025 (0.635)	0.005 (0.127)	0.003 (0.076)	0.002 (0.051)	0.002 (0.051)	0.003 (0.076)	0.005 (0.127)
8	0.035 (0.889)	0.005 (0.127)	0.003 (0.076)	0.002 (0.051)	0.002 (0.051)	0.003 (0.076)	0.005 (0.127)

NOTE 1—Use additional layers of shim material as required. The layers shall be 1 by 1.625 in. (25.4 by 41.275 mm). The additional shim material shall be identified by the placement of lead numbers which denote the thickness immediately adjacent to the IQI during exposure, or as an alternative, documented on the radiographic technique.

NOTE 2—Tolerance is ± 0.001 in. (0.025 mm) where dimensions are 0.000 and ± 0.003 in. (0.076 mm) where dimensions are 0.00.

NOTE 3—Bond materials together with cyanoacrylic or equivalent fast-drying epoxy.

NOTE 4—Particle holes are 0.031 in. (0.787 mm) nominal diameter.

NOTE 5—Tolerance on particle diameter is + 0.0003 in. (0.0076 mm).

NOTE 6—Wire grooves are 0.007 in. (0.178 mm) depth with 90° inclusive angle.

NOTE 7—The number hole is 0.25 in. (0.635 mm) nominal diameter and 0.125 in. (0.318 mm) deep.

higher power devices that have thicker coverings normally use larger interconnecting wires than small signal devices that use thin coverings. Particle size is normally independent of device type, so these remain constant.

6.2 The IQI used shall be the one with a radiographic density or grey level nearest to that of the electronic device being examined. The radiographic density or grey level is measured on an area of the IQI image that contains no wire or