



Standard Specification for Gong, Sound Signaling¹

This standard is issued under the fixed designation F957; the number immediately following the designation indicates the year of original adoption or, in the case of revision, the year of last revision. A number in parentheses indicates the year of last reapproval. A superscript epsilon (ϵ) indicates an editorial change since the last revision or reapproval.

This standard has been approved for use by agencies of the Department of Defense.

1. Scope

1.1 This specification covers gongs for use on ships 100 m or more in length, as required by International Regulations (see [Appendix X1](#)).

1.2 For consistency with International Regulations, all measurements are in SI units.

2. Referenced Documents

2.1 *ASTM Standards*:²

[A167 Specification for Stainless and Heat-Resisting Chromium-Nickel Steel Plate, Sheet, and Strip](#)

[A276 Specification for Stainless Steel Bars and Shapes](#)

[D3951 Practice for Commercial Packaging](#)

2.2 *American Welding Society Standard*:³

AWS D1.1 Structural Welding Code

2.3 *Federal Specifications*:⁴

[PPP-B-576](#) Box, Wood, Cleated, Veneer, Paper Overlaid

[PPP-B-585](#) Boxes, Wood, Wirebound

[PPP-B-591](#) Boxes, Fiberboard, Wood-cleated

[PPP-B-601](#) Boxes, Wood, Cleated Plywood

[PPP-B-621](#) Boxes, Wood, Nailed and Lock Corner

2.4 *Military Standard*:⁴

[MIL-STD-129](#) Marking for Shipment and Storage

3. Ordering Information

3.1 Orders for gongs under this specification shall include the following information:

3.1.1 ASTM designation and year of issue.

3.1.2 Number of gongs.

¹ This specification is under the jurisdiction of ASTM Committee F25 on Ships and Marine Technology and is the direct responsibility of Subcommittee F25.07 on General Requirements.

Current edition approved Dec. 1, 2006. Published January 2007. Originally approved in 1985. Last previous edition approved in 2001 as F957 – 91 (2001). DOI: 10.1520/F0957-91R06.

² For referenced ASTM standards, visit the ASTM website, www.astm.org, or contact ASTM Customer Service at service@astm.org. For *Annual Book of ASTM Standards* volume information, refer to the standard's Document Summary page on the ASTM website.

³ Available from American Welding Society (AWS), 550 NW LeJeune Rd., Miami, FL 33126, http://www.aws.org.

⁴ Available from Standardization Documents Order Desk, DODSSP, Bldg. 4, Section D, 700 Robbins Ave., Philadelphia, PA 19111-5098, http://www.dodssp.daps.mil.

3.1.3 Packaging and marking, if other than commercial.

4. Materials and Manufacture

4.1 *Materials*:

4.1.1 The gong cylinder, brackets, clapper rod, “U” bracket, washers, and clapper support pin shall be of stainless steel, in accordance with Specification [A167](#), UNS number S31600.

4.1.2 The clapper mass shall be of cast alloy steel in accordance with Specification [A276](#), UNS S31600.

4.1.3 The support bolt, nut, flat washer, and cotter pins shall be of stainless steel compatible with the other materials.

4.2 *Welding*:

4.2.1 Welding shall be of the type and sizes shown in [Fig. 1](#) and [Fig. 2](#), and in accordance with Standard AWS D1.1.

4.3 *Manufacture*:

4.3.1 [Fig. 1](#) shows the general arrangement of the assembled gong, as well as details of the gong cylinder. [Fig. 2](#) shows details of the brackets, clapper, and miscellaneous fittings.

4.3.2 The gong cylinder may be made from two pieces welded together, instead of one piece. Two piece construction shall be annealed to remove residual stresses.

4.3.3 Sharp corners and edges of the cylinder shall be broken.

4.3.4 The two brackets shall be welded together before being welded to the cylinder. The flanged ends of the brackets may be left straight and not shaped to the cylinder.

4.3.5 The clapper mass shall be welded to the clapper rod before forming the second eye.

4.4 *Extra Parts*:

4.4.1 Two extra supporting nuts and flat washers shall be furnished with each gong.

5. Acoustic Requirements

5.1 The sound characteristics shall produce a sound pressure level of not less than 110 dB at a distance of 1 m.

6. Dimensions and Tolerances

6.1 Dimensions shall conform to [Fig. 1](#) and [Fig. 2](#).

6.2 Tolerances shall be as follows:

6.2.1 Up to 10 mm: ± 1 mm.

6.2.2 10 mm to 50 mm: ± 2 mm.

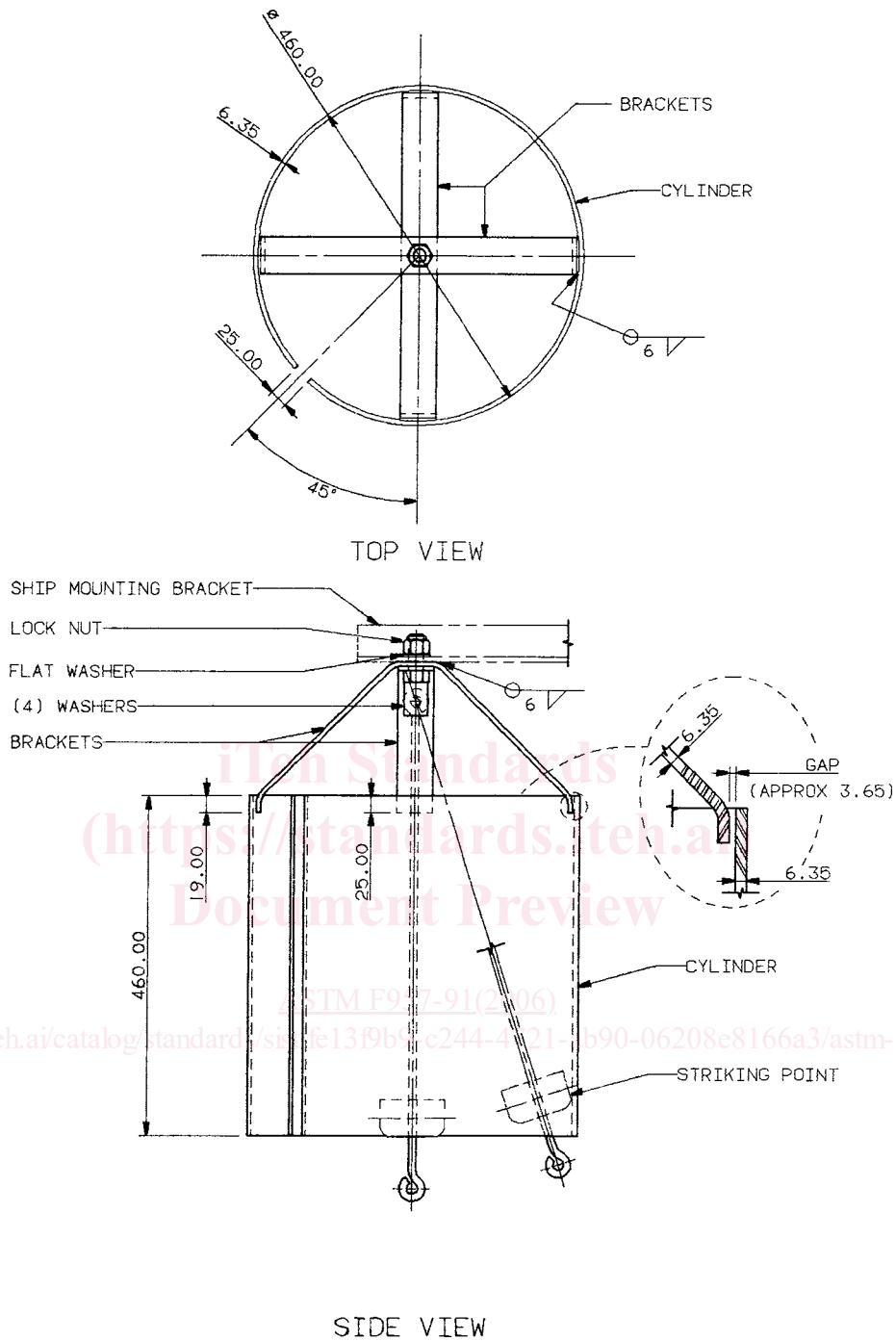

NOTE—All dimensions in millimetres.
FIG. 1 Assembly of Gong

6.2.3 Over 50 mm: ± 3 mm.

7. Workmanship, Finish, and Appearance

7.1 Gongs shall be free from cracks, burrs, sharp cutting edges, and other defects affecting their life, appearance, and serviceability.

8. Sampling

8.1 For orders of 1 or 2 gongs, each gong shall be inspected and tested.

8.2 For orders of 3 to 10 gongs, 2 gongs shall be selected at random. If any one of them fails to meet requirements, then all gongs in the order shall be inspected and tested.

8.3 For orders of more than 10 gongs, they shall be separated into groups of 10 (or fraction thereof) for sampling purposes.

9. Inspection and Testing

9.1 *Responsibility*—Unless otherwise specified in the purchase order, the manufacturer shall be responsible for the