



**SLOVENSKI STANDARD**  
**SIST EN 13190:2002**  
**01-junij-2002**

---

**Kazalni termometri**

Dial thermometers

Zeigerthermometer

Thermometres a cadran

**ITEH STANDARD PREVIEW**  
**(standards.iteh.ai)**

**Ta slovenski standard je istoveten z: EN 13190:2001**

[SIST EN 13190:2002](https://standards.iteh.ai/catalog/standards/sist/79af2fe3-7d13-4af2-b034-9f3edb76a9ab/sist-en-13190-2002)

<https://standards.iteh.ai/catalog/standards/sist/79af2fe3-7d13-4af2-b034-9f3edb76a9ab/sist-en-13190-2002>

**ICS:**

17.200.20	Instrumenti za merjenje temperature	Temperature-measuring instruments
-----------	-------------------------------------	-----------------------------------

**SIST EN 13190:2002**

**en**

**iTeh STANDARD PREVIEW**  
**(standards.iteh.ai)**

SIST EN 13190:2002

<https://standards.iteh.ai/catalog/standards/sist/79af2fe3-7d13-4af2-b034-9f3edb76a9ab/sist-en-13190-2002>

EUROPEAN STANDARD  
NORME EUROPÉENNE  
EUROPÄISCHE NORM

**EN 13190**

November 2001

ICS 17.200.20

English version

**Dial thermometers**

Thermomètres à cadran

Zeigerthermometer

This European Standard was approved by CEN on 28 September 2001.

CEN members are bound to comply with the CEN/CENELEC Internal Regulations which stipulate the conditions for giving this European Standard the status of a national standard without any alteration. Up-to-date lists and bibliographical references concerning such national standards may be obtained on application to the Management Centre or to any CEN member.

This European Standard exists in three official versions (English, French, German). A version in any other language made by translation under the responsibility of a CEN member into its own language and notified to the Management Centre has the same status as the official versions.

CEN members are the national standards bodies of Austria, Belgium, Czech Republic, Denmark, Finland, France, Germany, Greece, Iceland, Ireland, Italy, Luxembourg, Netherlands, Norway, Portugal, Spain, Sweden, Switzerland and United Kingdom.

**(standards.iteh.ai)**

SIST EN 13190:2002

<https://standards.iteh.ai/catalog/standards/sist/79af2fe3-7d13-4af2-b034-9f3edb76a9ab/sist-en-13190-2002>



EUROPEAN COMMITTEE FOR STANDARDIZATION  
COMITÉ EUROPÉEN DE NORMALISATION  
EUROPÄISCHES KOMITEE FÜR NORMUNG

**Management Centre: rue de Stassart, 36 B-1050 Brussels**

**iTeh STANDARD PREVIEW**  
**(standards.iteh.ai)**

SIST EN 13190:2002

<https://standards.iteh.ai/catalog/standards/sist/79af2fe3-7d13-4af2-b034-93edb76a9ab/sist-en-13190-2002>

**iTeh STANDARD PREVIEW**  
**(standards.iteh.ai)**

SIST EN 13190:2002

<https://standards.iteh.ai/catalog/standards/sist/79af2fe3-7d13-4af2-b034-93edb76a9ab/sist-en-13190-2002>

**iTeh STANDARD PREVIEW**  
**(standards.iteh.ai)**

SIST EN 13190:2002

<https://standards.iteh.ai/catalog/standards/sist/79af2fe3-7d13-4af2-b034-93edb76a9ab/sist-en-13190-2002>

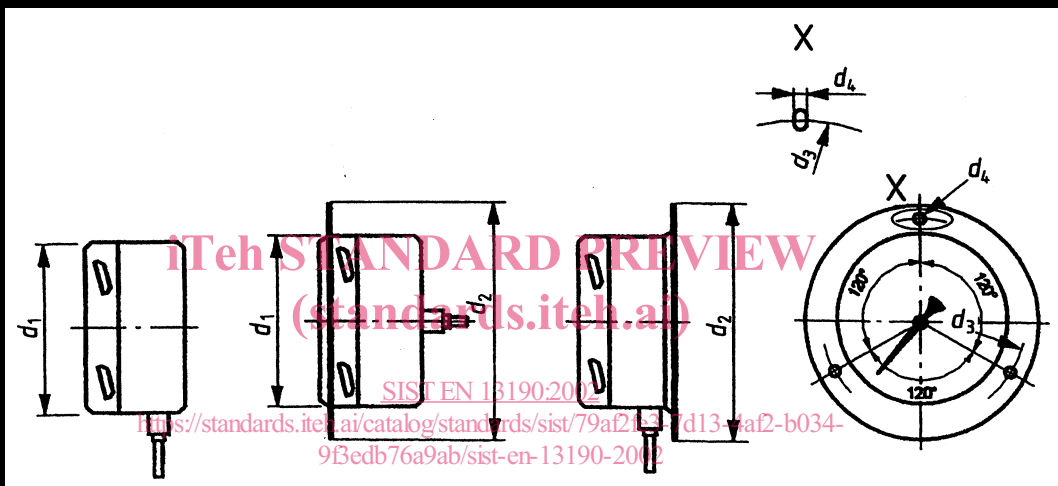

**iTeh STANDARD PREVIEW**  
**(standards.iteh.ai)**

SIST EN 13190:2002

<https://standards.iteh.ai/catalog/standards/sist/79af2fe3-7d13-4af2-b034-93edb76a9ab/sist-en-13190-2002>



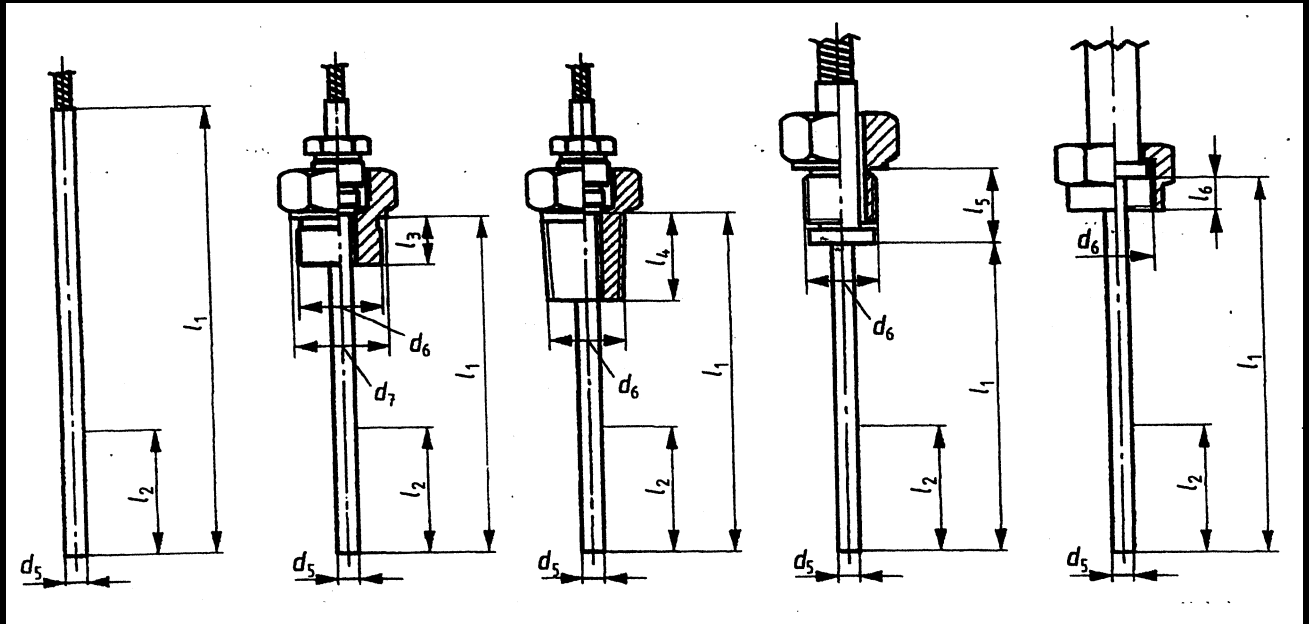

## iTeh STANDARD PREVIEW (standards.iteh.ai)

<https://standards.iteh.ai/catalog/standards/sist/79af2fe3-7d13-4af2-b034-93bedb76a266/sist-en-13190-2002>

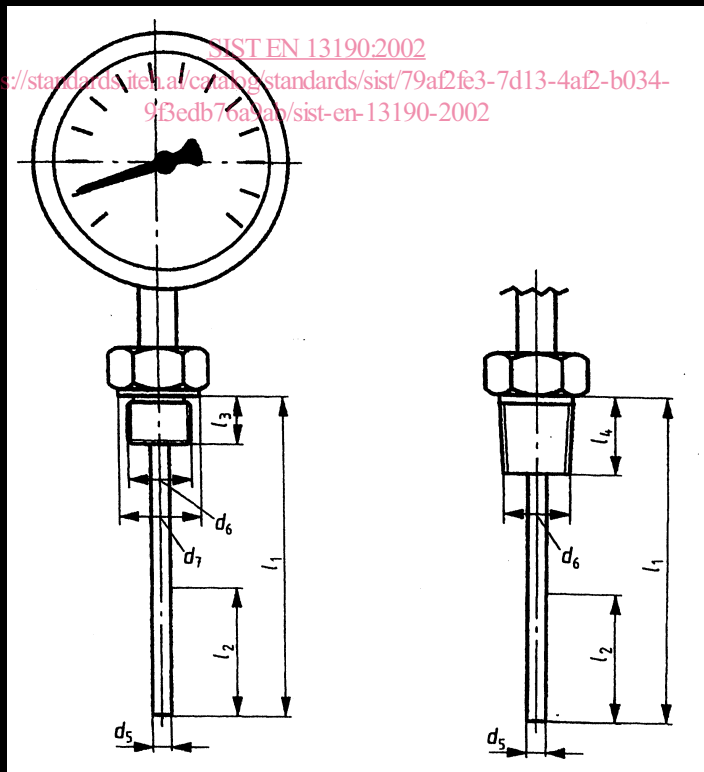

**iTeh STANDARD PREVIEW**  
**(standards.iteh.ai)**

SIST EN 13190:2002

<https://standards.iteh.ai/catalog/standards/sist/79af2fe3-7d13-4af2-b034-93edb76a9ab/sist-en-13190-2002>

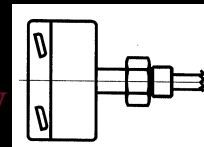
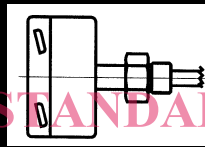
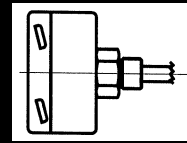
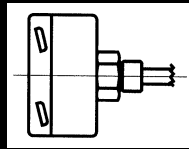
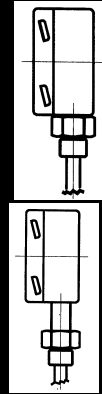
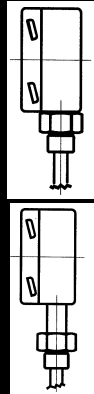

iTeh STANDARD PREVIEW  
(standards.iteh.ai)

[SIST EN 13190:2002](https://standards.iteh.ai/catalog/standards/sist/79af2fe3-7d13-4af2-b034-93edb76a9ab/sist-en-13190-2002)

<https://standards.iteh.ai/catalog/standards/sist/79af2fe3-7d13-4af2-b034-93edb76a9ab/sist-en-13190-2002>

