**Sintered metal materials, excluding
hardmetals — Tensile test pieces**

*Matériaux en métal fritté, à l'exclusion des métaux-durs — Éprouvettes
pour essai de traction*

iTeh STANDARD PREVIEW
(standards.iteh.ai)

[ISO 2740:2009](https://standards.iteh.ai/catalog/standards/sist/b54d7617-42a0-408b-9587-441a30b2a609/iso-2740-2009)

[https://standards.iteh.ai/catalog/standards/sist/b54d7617-42a0-408b-
9587-441a30b2a609/iso-2740-2009](https://standards.iteh.ai/catalog/standards/sist/b54d7617-42a0-408b-9587-441a30b2a609/iso-2740-2009)



PDF disclaimer

This PDF file may contain embedded typefaces. In accordance with Adobe's licensing policy, this file may be printed or viewed but shall not be edited unless the typefaces which are embedded are licensed to and installed on the computer performing the editing. In downloading this file, parties accept therein the responsibility of not infringing Adobe's licensing policy. The ISO Central Secretariat accepts no liability in this area.

Adobe is a trademark of Adobe Systems Incorporated.

Details of the software products used to create this PDF file can be found in the General Info relative to the file; the PDF-creation parameters were optimized for printing. Every care has been taken to ensure that the file is suitable for use by ISO member bodies. In the unlikely event that a problem relating to it is found, please inform the Central Secretariat at the address given below.

iTeh STANDARD PREVIEW
(standards.iteh.ai)

ISO 2740:2009

<https://standards.iteh.ai/catalog/standards/sist/b54d7617-42a0-408b-9587-441a30b2a609/iso-2740-2009>



COPYRIGHT PROTECTED DOCUMENT

© ISO 2009

All rights reserved. Unless otherwise specified, no part of this publication may be reproduced or utilized in any form or by any means, electronic or mechanical, including photocopying and microfilm, without permission in writing from either ISO at the address below or ISO's member body in the country of the requester.

ISO copyright office
Case postale 56 • CH-1211 Geneva 20
Tel. + 41 22 749 01 11
Fax + 41 22 749 09 47
E-mail copyright@iso.org
Web www.iso.org

Published in Switzerland

Contents

Page

Foreword.....	iv
1 Scope	1
2 Normative references	1
3 Method of testing	1
4 Manufacture of test pieces	1
5 Metal injection-moulded test pieces	2
6 Machined test pieces	2
7 Identification of test pieces	3

iTeh STANDARD PREVIEW
(standards.iteh.ai)

ISO 2740:2009

<https://standards.iteh.ai/catalog/standards/sist/b54d7617-42a0-408b-9587-441a30b2a609/iso-2740-2009>

Foreword

ISO (the International Organization for Standardization) is a worldwide federation of national standards bodies (ISO member bodies). The work of preparing International Standards is normally carried out through ISO technical committees. Each member body interested in a subject for which a technical committee has been established has the right to be represented on that committee. International organizations, governmental and non-governmental, in liaison with ISO, also take part in the work. ISO collaborates closely with the International Electrotechnical Commission (IEC) on all matters of electrotechnical standardization.

International Standards are drafted in accordance with the rules given in the ISO/IEC Directives, Part 2.

The main task of technical committees is to prepare International Standards. Draft International Standards adopted by the technical committees are circulated to the member bodies for voting. Publication as an International Standard requires approval by at least 75 % of the member bodies casting a vote.

Attention is drawn to the possibility that some of the elements of this document may be the subject of patent rights. ISO shall not be held responsible for identifying any or all such patent rights.

ISO 2740 was prepared by Technical Committee ISO/TC 119, *Powder metallurgy*, Subcommittee SC 3, *Sampling and testing methods for sintered metal materials (excluding hardmetals)*.

This fifth edition cancels and replaces the fourth edition (ISO 2740:2007), of which it constitutes a minor revision.

iTeh STANDARD PREVIEW
(standards.iteh.ai)

[ISO 2740:2009](https://standards.iteh.ai/catalog/standards/sist/b54d7617-42a0-408b-9587-441a30b2a609/iso-2740-2009)

<https://standards.iteh.ai/catalog/standards/sist/b54d7617-42a0-408b-9587-441a30b2a609/iso-2740-2009>

Sintered metal materials, excluding hardmetals — Tensile test pieces

1 Scope

This International Standard is applicable to all sintered metals and alloys, excluding hardmetals.

This International Standard specifies:

- the die cavity dimensions used for making tensile test pieces by pressing and sintering, and by Metal Injection Moulding (MIM) and sintering;
- the dimensions of tensile test pieces machined from sintered and powder forged materials.

2 Normative references

The following referenced documents are indispensable for the application of this document. For dated references, only the edition cited applies. For undated references, the latest edition of the referenced document (including any amendments) applies.

ISO 6892, *Metallic materials — Tensile testing at ambient temperature*

ISO 7500-1, *Metallic materials — Verification of static uniaxial testing machines — Part 1: Tension/compression testing machines — Verification and calibration of the force-measuring system*

3 Method of testing

3.1 Test pieces shall be tested in accordance with ISO 6892, and the tensile test machine shall be calibrated to Class 1, in accordance with ISO 7500-1.

3.2 Data are to be reported for three or more test pieces.

4 Manufacture of test pieces

4.1 Pressed and sintered test pieces

The tensile test pieces shall have thicknesses from 5 mm to 6,5 mm. A thickness tolerance of 1,5 mm accommodates varying apparent densities in metal powders. During testing, the thinner pieces have less grip slippage and are more likely to break near the centre of the gauge length.

If necessary for measuring elongation, marks may be lightly scribed 25 mm apart and symmetrically about the centre line [see Figures 1 a) and 2 a)]. Between the scribed marks, the thickness shall not vary by more than 0,04 mm. The gauge length shall be scribed in such a way that the tensile properties are not affected.

Because of the possibility of creating microlaminations in the corners of test pieces compacted under laboratory conditions, representative sintered test pieces shall be examined metallographically to show that there are no microlaminations longer than 0,25 mm.

4.2 Die specifications

The dimensions of the two permitted die cavities are shown in Figures 1 b) and 2 b). The dies should preferably be of hardmetal and their surface finish shall be such as to allow compression of the test pieces under normal conditions. Dies may include a small exit taper to facilitate ejection and to avoid cracks or microlaminations in the test pieces. A die cavity tapered 0,01 per side, to aid ejection, may be enlarged by 0,5 % for tooling to be used for repressing. The dies should be well supported with shrink rings, so as to minimize lateral expansion during compacting. Such a support decreases the possibility of cracking of the specimen at ejection. To reduce the incidence of cracks in the specimen, it is recommended to use top-punch hold-down during ejection.

The die in Figure 1 b) is recommended for as-sintered test pieces. Gripping is readily accomplished by sliding the 20° wedge faces of the test piece into matching pockets machined in the grips. Figure 1 a) shows the test piece.

The die in Figure 2 b) is recommended for as-sintered test pieces. The test piece is gripped on the raised serrations compacted on its gripping ends, to prevent slippage during testing. It is important for testing that the grips fit properly into the clevis. Alternatively, the test piece is compacted without serrations and gripped on the flat faces.

Test pieces made from the dies in Figure 1 b) or 2 b) are recommended for materials to be tested in the as-sintered condition. When testing relatively brittle, heat-treated materials, the constraint of the test piece's sharp corners can result in tensile values that are lower than those obtained with machined tensile test pieces (see Figure 5).

[ISO 2740:2009](#)

5 Metal injection-moulded test pieces

[http://www.iso.org/standards/catalog/standards/sist/b54d7617-42a0-408b-9587-441a30b2a609/iso-2740-2009](#)

Figure 3 shows a larger diameter of the die cavity for Metal Injection Moulding (MIM) tensile test pieces of type A. Figure 4 shows a smaller die cavity for MIM tensile test pieces of type B. During testing, the through-holes are intended to surround hardened steel pins. The pins are gripped in a clevis, and mounted on a testing machine in a self-aligning manner. The holes may optionally be drilled after sintering, rather than moulded with no draft permitted. These optional hole diameters should be: a diameter of $6,5 \text{ mm} +_{0}^{0,25} \text{ mm}$ for a large bar or a diameter of $4,77 \text{ mm} +_{0}^{0,25} \text{ mm}$ for a small bar, after sintering. The die dimensions assume about 17 % shrinkage during sintering, but variations in shrinkage are permitted. Either bar design may be used. Gauge marks may be scribed as noted in 4.1.

The gate, manufacturer's identification and ejector location are optional, but shall not be in the gauge length L_C and not in the gripping area.

6 Machined test pieces

6.1 Figure 5 shows the dimensions of a machined button-head tensile test piece. This is conveniently machined from a standard 10 mm × 10 mm × 75 mm impact bar. The taper of 0,1 mm in the nominal diameters, over the gauge length, generally results in fracture occurring within the gauge region, even for relatively brittle materials.

If a material is to be carburized after grinding, the surface pores in the gauge region shall be left open to allow carburizing gases to enter. Final polishing shall be in the longitudinal direction (no circumferential scratch lines shall be visible).

The test piece is gripped by a split collet, closely surrounding the 20° tapered region. During testing, the test piece is supported on the same taper. The test piece may have a 25 mm gauge length lightly scribed as in 4.1.

This test piece is primarily recommended for testing materials in the heat-treated condition, where elongations at fracture may be < 0,5 % in 25 mm. This test piece is recommended for use when the volume fraction of martensite is > 20 %, regardless of whether the test piece is as-sintered or heat-treated. Some work-hardening occurs during machining, and if the test piece is tested in the sintered and machined condition, the work-hardening can lower elongation and raise yield strength. This is particularly true for stainless steels.

During austenitizing and oil quenching, the usual sintered alloy steels may not fully harden to the centre of the machined test pieces. Such test pieces may be further qualified in the report, by indicating the hardness from the surface to the core.

6.2 Other cylindrical machined test pieces are possible and should conform to ISO 6892.

When the diameter of the useful part of the test pieces is less than 4 mm, its value shall be stated together with the fact that the results of the test may not be comparable with those obtained from test pieces of larger diameters.

For sintered products, it is recommended that a test piece having two shoulders at each end be used. The radius of the inner shoulder shall be between 1,5 mm and 2,5 mm (see Figure 5).

7 Identification of test pieces

For the identification of test pieces, the following shall be stated:

- a) a reference to this International Standard, i.e. ISO 2740;
[ISO 2740:2009](https://standards.iteh.ai/catalog/standards/sist/b54d7617-42a0-408b-9587-441a30b2a609/iso-2740-2009)
- b) type of material; <https://standards.iteh.ai/catalog/standards/sist/b54d7617-42a0-408b-9587-441a30b2a609/iso-2740-2009>
- c) density of test piece;
- d) dimensions of test piece (thickness);
- e) when pressed and sintered test pieces are made according to 4.1, the nature of any finishing treatment and also, preferably, the material and the surface finish of the compacting tool;
- f) form of test piece, i.e. figure number of this International Standard;
- g) die material, i.e. tool steel or hardmetal/carbide;
- h) whether as-sintered or heat-treated;
- i) hardness of test piece according to the heat treatment.

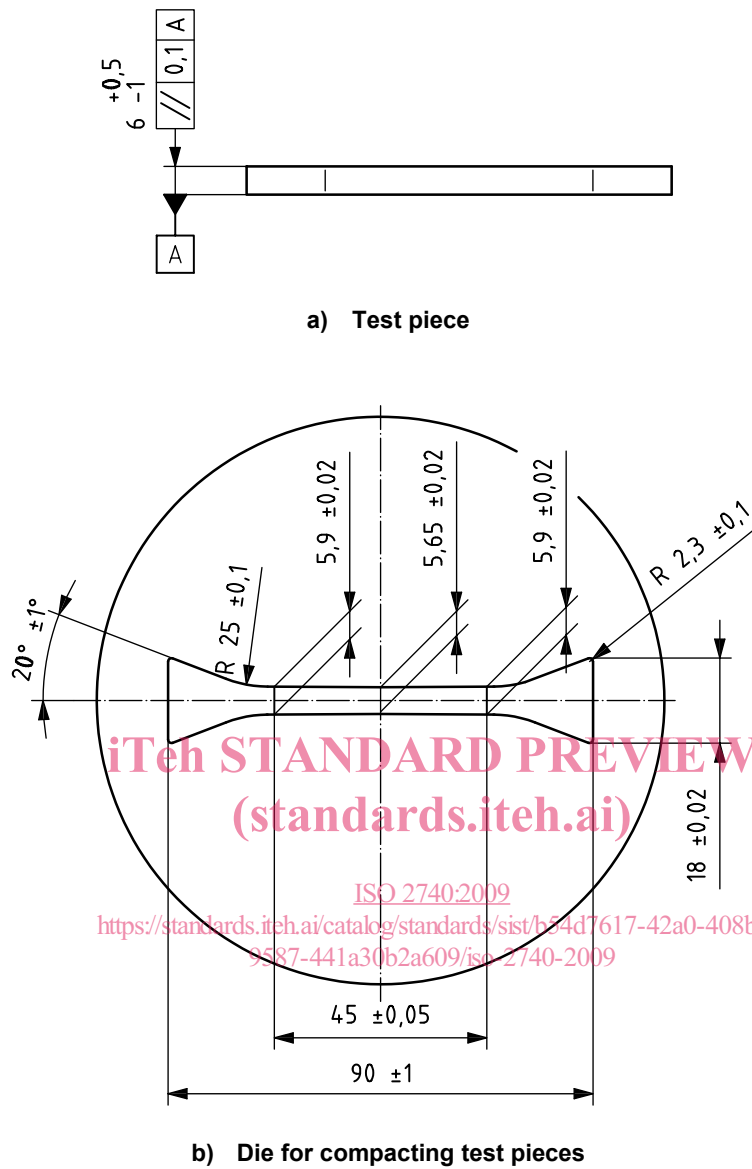
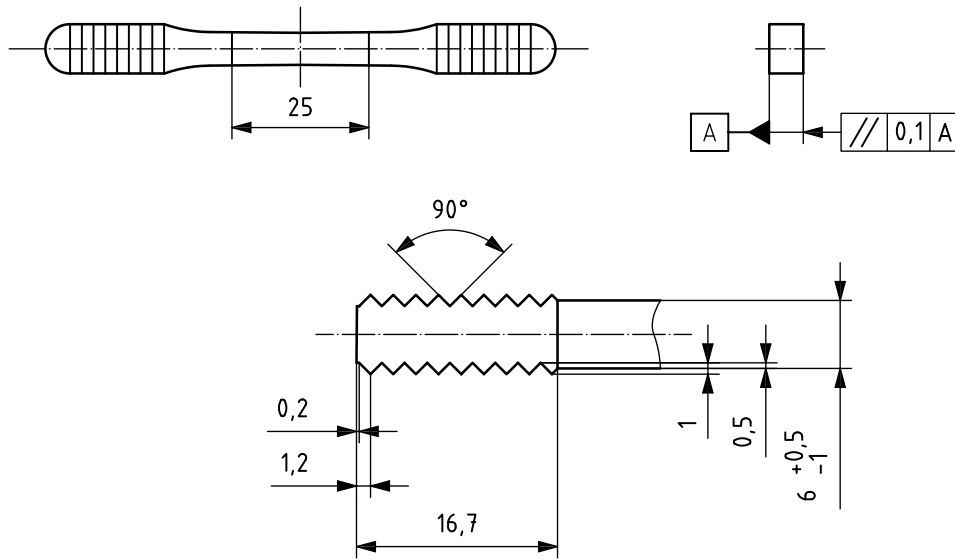
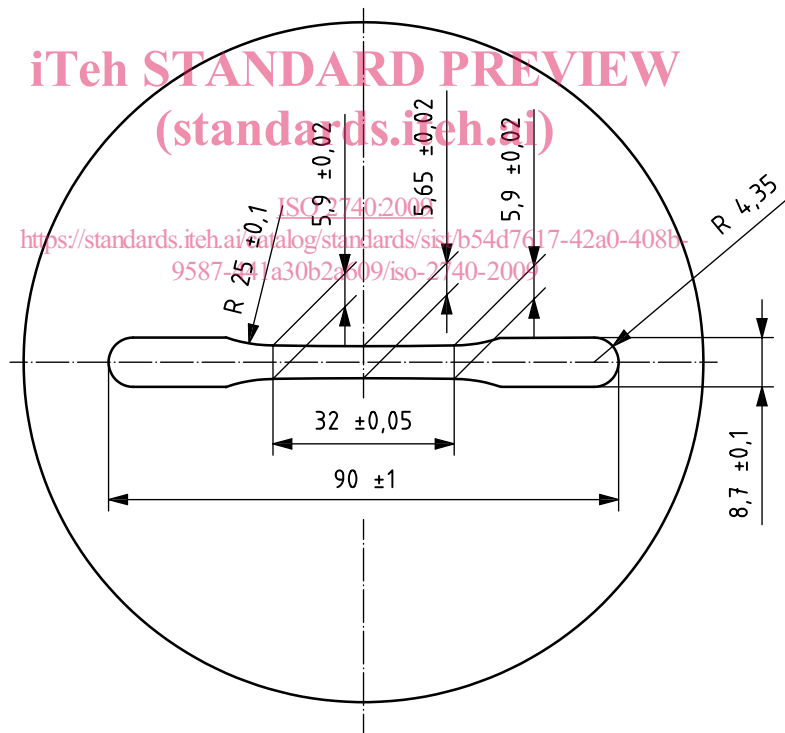

Figure 1 — Test piece and die for tensile testing — Smooth grips

Dimensions in millimetres



a) Test piece



b) Die for compacting test pieces

Figure 2 — Test piece and die for tensile testing — Serrated grips