

ETSI EN 301 489-12 V3.1.1 (2019-04)



**Electromagnetic compatibility
and Radio spectrum Matters (ERM);
ElectroMagnetic Compatibility (EMC)
standard for radio equipment and services;
Part 12: Specific conditions for Very Small Aperture
Terminal, Satellite Interactive Earth Stations operated
in the frequency ranges between 4 GHz and 30 GHz
in the Fixed Satellite Service (FSS)
Harmonised Standard for electromagnetic compatibility**

Reference

REN/ERM-EMC-366-12

Keywords

earth station, EMC, FSS, harmonised standard, radio, regulation, satellite, SNG, testing, VSAT

ETSI650 Route des Lucioles
F-06921 Sophia Antipolis Cedex - FRANCE

Tel.: +33 4 92 94 42 00 Fax: +33 4 93 65 47 16

Siret N° 348 623 562 00017 - NAF 742 C
Association à but non lucratif enregistrée à la
Sous-Préfecture de Grasse (06) N° 7803/88

Important noticeThe present document can be downloaded from:
<http://www.etsi.org/standards-search>

The present document may be made available in electronic versions and/or in print. The content of any electronic and/or print versions of the present document shall not be modified without the prior written authorization of ETSI. In case of any existing or perceived difference in contents between such versions and/or in print, the prevailing version of an ETSI deliverable is the one made publicly available in PDF format at www.etsi.org/deliver.

Users of the present document should be aware that the document may be subject to revision or change of status. Information on the current status of this and other ETSI documents is available at <https://portal.etsi.org/TB/ETSIDeliverableStatus.aspx>

If you find errors in the present document, please send your comment to one of the following services:
<https://portal.etsi.org/People/CommiteeSupportStaff.aspx>

Copyright Notification

No part may be reproduced or utilized in any form or by any means, electronic or mechanical, including photocopying and microfilm except as authorized by written permission of ETSI.

The content of the PDF version shall not be modified without the written authorization of ETSI.

The copyright and the foregoing restriction extend to reproduction in all media.

© ETSI 2019.
All rights reserved.

DECT™, **PLUGTESTS™**, **UMTS™** and the ETSI logo are trademarks of ETSI registered for the benefit of its Members.
3GPP™ and **LTE™** are trademarks of ETSI registered for the benefit of its Members and of the 3GPP Organizational Partners.

oneM2M™ logo is a trademark of ETSI registered for the benefit of its Members and of the oneM2M Partners.

GSM® and the GSM logo are trademarks registered and owned by the GSM Association.

Contents

Intellectual Property Rights	5
Foreword.....	5
Modal verbs terminology.....	5
1 Scope	6
2 References	6
2.1 Normative references	6
2.2 Informative references.....	6
3 Definitions and abbreviations.....	7
3.1 Definitions.....	7
3.2 Abbreviations	7
4 Test conditions	8
4.1 General	8
4.2 Arrangements for test signals	8
4.2.1 Arrangements for test signals at the input of transmitters.....	8
4.2.2 Arrangements for test signals at the output of transmitters.....	8
4.2.3 Arrangements for test signals at the input of receivers.....	8
4.2.4 Arrangements for test signals at the output of receivers.....	8
4.2.5 Arrangements for testing transmitter and receiver together (as a system).....	8
4.3 Exclusion bands.....	9
4.4 Narrow band responses of receivers.....	9
5 Performance assessment.....	9
5.1 General	9
5.2 Equipment configuration(s).....	9
5.3 Equipment classification	10
6 Performance criteria	10
6.0 General Performance criteria.....	10
6.1 Performance criteria (C) for Continuous phenomena applied to the EUT	10
6.2 Performance criteria (TA) for Transient phenomena applied to a grade A EUT.....	11
6.3 Performance criteria (TB) for Transient phenomena applied to a grade B EUT	11
7 Applicability overview	12
7.1 Emission.....	12
7.1.1 General.....	12
7.1.2 Special conditions.....	12
7.2 Immunity	12
7.2.1 General.....	12
7.2.2 Special conditions.....	12
Annex A (informative): Relationship between the present document and the essential requirements of Directive 2014/53/EU	14
Annex B (normative): Definitions of Satellite Earth Stations (ES) within the scope of the present document.....	16
B.0 General	16
B.1 Transmit only and Transmit and receive Ku band VSATs	16
B.2 Receive-only Ku band VSATs.....	16
B.3 Transmit only and Transmit and receive C band VSATs.....	17
B.4 Receive-only C band VSATs	17
B.5 Satellite News Gathering (SNG) Ku band Transportable Earth Stations (TESs).....	18

B.6	Satellite Interactive Terminals (SITs)	19
B.7	Satellite User Terminals (SUTs) transmitting in the frequency range 29,5 GHz to 30,0 GHz	19
B.8	Satellite User Terminals (SUTs) transmitting in the frequency range 27,5 GHz to 29,5 GHz	20
B.9	Satellite Earth Station on Trains (EST) transmitting in the frequency range 14,0 GHz to 14,5 GHz	21
Annex C (informative):	Bibliography	22
Annex D (informative):	Change history	23
History		24

iTeh STANDARD PREVIEW
(standards.iteh.ai)

Full standard:
<https://standards.iteh.ai/catalog/standards/sist/49140e59-fbe9-4a62-82ea-4a0dcca17f2/etsi-en-301-489-12-v3.1.1-2019-04>

Intellectual Property Rights

Essential patents

IPRs essential or potentially essential to normative deliverables may have been declared to ETSI. The information pertaining to these essential IPRs, if any, is publicly available for **ETSI members and non-members**, and can be found in ETSI SR 000 314: "*Intellectual Property Rights (IPRs); Essential, or potentially Essential, IPRs notified to ETSI in respect of ETSI standards*", which is available from the ETSI Secretariat. Latest updates are available on the ETSI Web server (<https://ipr.etsi.org/>).

Pursuant to the ETSI IPR Policy, no investigation, including IPR searches, has been carried out by ETSI. No guarantee can be given as to the existence of other IPRs not referenced in ETSI SR 000 314 (or the updates on the ETSI Web server) which are, or may be, or may become, essential to the present document.

Trademarks

The present document may include trademarks and/or tradenames which are asserted and/or registered by their owners. ETSI claims no ownership of these except for any which are indicated as being the property of ETSI, and conveys no right to use or reproduce any trademark and/or tradename. Mention of those trademarks in the present document does not constitute an endorsement by ETSI of products, services or organizations associated with those trademarks.

Foreword

This Harmonised European Standard (EN) has been produced by ETSI Technical Committee Electromagnetic compatibility and Radio spectrum Matters (ERM).

The present document has been prepared under the Commission's standardisation request C(2015) 5376 final [i.6] to provide one voluntary means of conforming to the essential requirements of Directive 2014/53/EU on the harmonisation of the laws of the Member States relating to the making available on the market of radio equipment and repealing Directive 1999/5/EC [i.5].

Once the present document is cited in the Official Journal of the European Union under that Directive, compliance with the normative clauses of the present document given in table A.1 confers, within the limits of the scope of the present document, a presumption of conformity with the corresponding essential requirements of that Directive and associated EFTA regulations.

The present document is part 12 of a multi-part deliverable. Full details of the entire series can be found in part 1 [1].

National transposition dates

Date of adoption of this EN:	3 January 2018
Date of latest announcement of this EN (doa):	31 July 2019
Date of latest publication of new National Standard or endorsement of this EN (dop/e):	31 January 2020
Date of withdrawal of any conflicting National Standard (dow):	31 January 2021

Modal verbs terminology

In the present document "**shall**", "**shall not**", "**should**", "**should not**", "**may**", "**need not**", "**will**", "**will not**", "**can**" and "**cannot**" are to be interpreted as described in clause 3.2 of the [ETSI Drafting Rules](#) (Verbal forms for the expression of provisions).

"**must**" and "**must not**" are **NOT** allowed in ETSI deliverables except when used in direct citation.

1 Scope

The present document, together with ETSI EN 301 489-1 [1], covers the assessment of Earth Stations (ES) operated in the frequency ranges between 4 GHz and 30 GHz in the Fixed Satellite Service (FSS) and associated ancillary equipment in respect of Electromagnetic Compatibility (EMC).

Technical specifications related to the antenna port and emissions from the enclosure port of the Earth Stations (ES) are not included in the present document. Such technical specifications are found in the relevant product standards for the effective use of the radio spectrum.

The present document specifies the applicable test conditions, performance assessment and the performance criteria for the ESs, and associated ancillary equipment.

Definitions of the type of Earth Stations (ES) operated in the frequency ranges between 4 GHz and 30 GHz in the Fixed Satellite Service (FSS) covered by the present document are given in annex B.

In case of differences (for instance concerning special conditions, definitions, abbreviations) between the present document and ETSI EN 301 489-1 [1], the provisions of the present document take precedence.

The environmental classification and the emission and immunity requirements used in the present document are as stated in ETSI EN 301 489-1 [1], except for any special conditions included in the present document. The applicable environments referred to in ETSI EN 301 489-1 [1] where equipment covered by the scope of the present document may be used, should be declared by the manufacturer.

NOTE: The relationship between the present document and essential requirements of article 3.1(b) of Directive 2014/53/EU [i.5] is given in annex A.

2 References

2.1 Normative references

References are specific, identified by date of publication and/or edition number or version number. Only the cited version applies.

Referenced documents which are not found to be publicly available in the expected location might be found at <https://docbox.etsi.org/Reference/>.

NOTE: While any hyperlinks included in this clause were valid at the time of publication, ETSI cannot guarantee their long term validity.

The following referenced documents are necessary for the application of the present document.

- [1] ETSI EN 301 489-1 (V2.2.0) (03-2017): "ElectroMagnetic Compatibility (EMC) standard for radio equipment and services; Part 1: Common technical requirements; Harmonised Standard covering the essential requirements of article 3.1(b) of Directive 2014/53/EU and the essential requirements of article 6 of Directive 2014/30/EU".

2.2 Informative references

References are either specific (identified by date of publication and/or edition number or version number) or non-specific. For specific references, only the cited version applies. For non-specific references, the latest version of the referenced document (including any amendments) applies.

NOTE: While any hyperlinks included in this clause were valid at the time of publication, ETSI cannot guarantee their long term validity.

The following referenced documents are not necessary for the application of the present document but they assist the user with regard to a particular subject area.

- [i.1] Void.

- [i.2] Void.
- [i.3] ERC/DEC(00)08: "ERC Decision of 19 October 2000 on the use of the band 10.7 - 12.5 GHz by the fixed service and Earth stations of the broadcasting-satellite and fixed-satellite Service (space-to-Earth)".
- [i.4] ERC/DEC(00)07: "ERC Decision of 19 October 2000 on the shared use of the band 17.7 - 19.7 GHz by the fixed service and Earth stations of the fixed-satellite service (space-to-Earth)".
- [i.5] Directive 2014/53/EU of the European Parliament and of the Council of 16 April 2014 on the harmonisation of the laws of the Member States relating to the making available on the market of radio equipment and repealing Directive 1999/5/EC.
- [i.6] Commission Implementing Decision C(2015) 5376 final of 4.8.2015 on a standardisation request to the European Committee for Electrotechnical Standardisation and to the European Telecommunications Standards Institute as regards radio equipment in support of Directive 2014/53/EU of the European Parliament and of the Council.

3 Definitions and abbreviations

3.1 Definitions

For the purposes of the present document, the terms and definitions given in ETSI EN 301 489-1 [1] and the following apply:

carrier-on state: transmit ES is in this state when it is authorized to transmit, and when it transmits a signal, either authorized by a Centralized Control and Monitoring Function (CCMF) or a Network Control Facility (NCF) when designed for unattended operation or by local control when designed for attended operation

carrier-off state: transmit ES is in this state when it is authorized to transmit, and when it does not transmit any signal, either authorized by a CCMF or a NCF when designed for unattended operation or by local control when designed for attended operation

NOTE: The existence of a carrier-off state depends on the system of transmission used. For ES designed for continuous transmission mode there may be no carrier-off state.

transmission disabled state: transmit ES is in this state when it is not authorized to transmit either by a CCMF or a NCF respectively when designed for unattended operation or by local control when designed for attended operation

3.2 Abbreviations

For the purposes of the present document, the following abbreviations apply:

AC	Alternating Current
AMSS	Aeronautical Mobile Satellite Service
BSS	Broadcast Satellite Service
CCMF	Centralized Control and Monitoring Functions
DC	Direct Current
EIRP	Equivalent Isotropically Radiated Power
EMC	ElectroMagnetic Compatibility
EME	Externally Mounted Equipment
ES	Earth Station
EST	Earth Station on Trains
EUT	Equipment Under Test
FS	Fixed Services
FSS	Fixed Satellite Service
IME	Internally Mounted Equipment
kV	kilovolt
LMSS	Land Mobile Satellite Service
LNB	Low Noise Block converter

MMSS	Marine Mobile Satellite Service
MSS	Mobile Satellite Service
NCF	Network Control Facility
QTMA	Quality of Transmission Measurement Apparatus
SIT	Satellite Interactive Terminals
SNG	Satellite News Gathering
SUT	Satellite User Terminals
TA	Transient phenomena applied to a grade A EUT
TB	Transient phenomena applied to a grade B EUT
TES	Transportable Earth Station
VSAT	Very Small Aperture Terminal

4 Test conditions

4.1 General

For the purposes of the present document, the test conditions of ETSI EN 301 489-1 [1], clause 4 shall apply as appropriate. Further product type related test conditions for Earth Stations are specified in the present document.

For Earth Stations with or without ancillary equipment, and/or various terrestrial ports, the number of test configurations shall be determined. The assessment shall include sufficient representative configurations of the ES to adequately exercise the equipment. These configurations shall be recorded in the test report.

In the following clauses, the Equipment Under Test (EUT) is an ES with the selected configuration of ancillary equipment.

4.2 Arrangements for test signals

4.2.1 Arrangements for test signals at the input of transmitters

The provisions of ETSI EN 301 489-1 [1], clause 4.2.1 shall apply.

4.2.2 Arrangements for test signals at the output of transmitters

The provisions of ETSI EN 301 489-1 [1], clause 4.2.2 shall apply.

4.2.3 Arrangements for test signals at the input of receivers

The provisions of ETSI EN 301 489-1 [1], clause 4.2.3 shall apply with the following modification.

For tests on the receiver, the level of the signal received from the test transmitter shall be as close as possible to the normal operation level of the EUT receiver.

4.2.4 Arrangements for test signals at the output of receivers

The provisions of ETSI EN 301 489-1 [1], clause 4.2.4 shall apply.

4.2.5 Arrangements for testing transmitter and receiver together (as a system)

The provisions of ETSI EN 301 489-1 [1], clause 4.2.5 shall apply.

4.3 Exclusion bands

There are no exclusion bands for ESs within the scope of the present document.

4.4 Narrow band responses of receivers

Narrow band responses are not allowed for ESs within the scope of the present document.

5 Performance assessment

5.1 General

The provision of ETSI EN 301 489-1 [1], clause 5.1 shall apply.

In addition the manufacturer shall provide the following information to be recorded in the test report:

- the dedicated grade (A or B) for the ES in accordance with the information contained in the instructions accompanying the ES (see clause 5.3);
- the ranges of the operational parameters, e.g. the power delivered to the antenna, the frequency ranges;
- the minimum quality of transmission, and the method to be used to assess it.

This information shall be in accordance with the documentation accompanying the equipment.

5.2 Equipment configuration(s)

For radiation measurements in carrier-on state, the ES shall be put in a continuous transmit mode or to the maximum burst rate where applicable. The ES shall be operated at the highest normal operating Equivalent Isotropically Radiated Power (EIRP) or, if that is the maximum attainable, then 3 dB below such maximum.

A suggested test configuration is shown in figure 1.

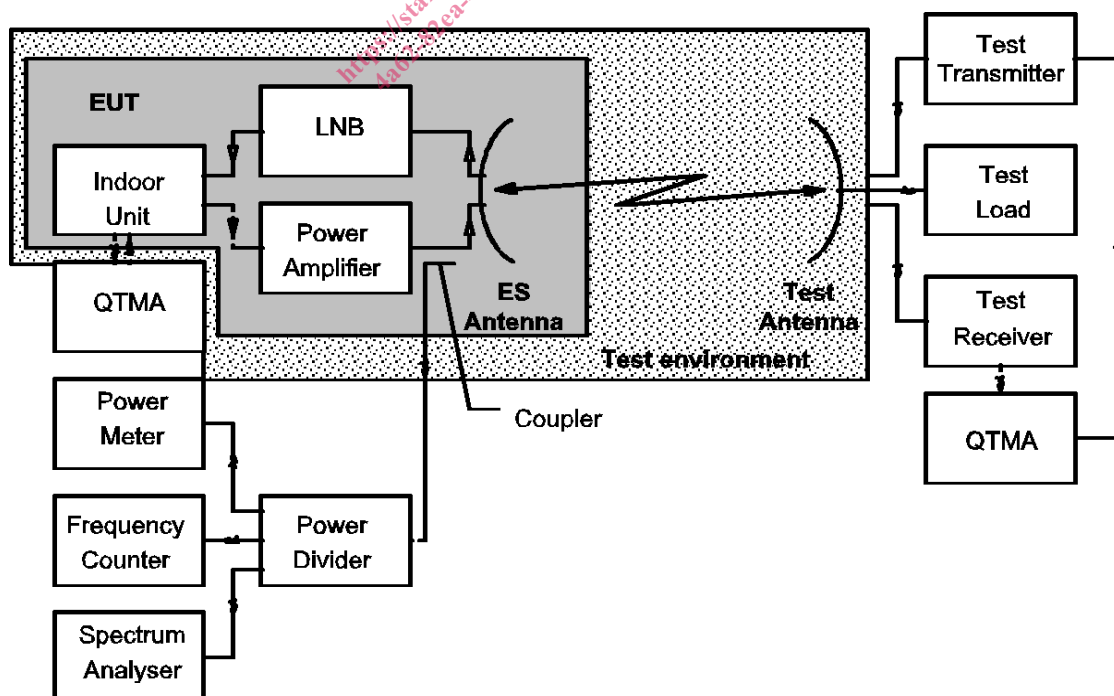

Figure 1: Suggested test configuration

For the tests, the ES antenna reflector and the test antenna may be removed at their flanges and be replaced by one direct wave guide connection.

The following test equipment shall be the means whereby the correct operation of the EUT is verified:

- a) the power meter measures the output power and is used to confirm the transmission disabled, carrier-on and carrier-off states and output level consistency;
- b) the frequency counter measures the centre frequency of the radiated carrier in the absence of modulation;
- c) the spectrum analyser measures the bandwidth of the transmission;
- d) the test receiver is used to demodulate the transmitted signal;
- e) the two QTMA are used in conjunction with each other to assess the quality of transmission;
- f) the test transmitter is used to control the switching between transmission disabled, carrier-on and carrier-off states by transmitting the control and monitoring signals.

5.3 Equipment classification

The provisions of ETSI EN 301 489-1 [1], clause 5.5 set out for base stations shall apply with the following addition.

The equipment are classified into the two grades of service:

- grade A of ES for which short interruptions of transmission are accepted during immunity testing with EMC transient phenomena;
- grade B of ES for which no short interruption of transmission is accepted during immunity testing with EMC transient phenomena.

The applicable grade A or B shall be declared by the manufacturer, it shall be in accordance with the information contained in the instructions accompanying the ES, and shall be recorded in the test report.

6 Performance criteria

6.0 General Performance criteria

The definition of the functions of the EUT, including its ancillary equipment, to be checked during and after the EMC tests shall be declared by the manufacturer and recorded in the test report.

The equipment shall meet the minimum performance criteria as specified in clauses 6.1, 6.2 and 6.3 and additionally the functions as declared by the manufacturer.

6.1 Performance criteria (C) for Continuous phenomena applied to the EUT

The provisions of ETSI EN 301 489-1 [1], clause 6.1 shall apply with the following modification.

The EUT shall be considered to satisfy the immunity if the following conditions are met during and after the exposure:

- a) the quality of transmission observed is no worse than that declared by the manufacturer (clause 5.1);
- b) the EUT is able to be placed in the transmission disabled state, and does not leave that state without being commanded;
- c) when the EUT is in the transmission disabled state there is no change in the signal level;
- d) when the EUT is in the carrier-on state there is no change in the signal level or frequency;