**Diesel engines — Clamp mounted CR fuel
injectors — Mounting dimensions**

*Moteurs diesels — Injecteurs de combustible pour rampe commune
fixés par patte — Dimensions de montage*

iTeh STANDARD PREVIEW
(standards.iteh.ai)

[ISO 12251:2011](https://standards.iteh.ai/catalog/standards/sist/8007e00a-597b-4f34-840c-7883c7179bf5/iso-12251-2011)

<https://standards.iteh.ai/catalog/standards/sist/8007e00a-597b-4f34-840c-7883c7179bf5/iso-12251-2011>



PDF disclaimer

This PDF file may contain embedded typefaces. In accordance with Adobe's licensing policy, this file may be printed or viewed but shall not be edited unless the typefaces which are embedded are licensed to and installed on the computer performing the editing. In downloading this file, parties accept therein the responsibility of not infringing Adobe's licensing policy. The ISO Central Secretariat accepts no liability in this area.

Adobe is a trademark of Adobe Systems Incorporated.

Details of the software products used to create this PDF file can be found in the General Info relative to the file; the PDF-creation parameters were optimized for printing. Every care has been taken to ensure that the file is suitable for use by ISO member bodies. In the unlikely event that a problem relating to it is found, please inform the Central Secretariat at the address given below.

iTeh STANDARD PREVIEW
(standards.iteh.ai)

ISO 12251:2011

<https://standards.iteh.ai/catalog/standards/sist/8007e00a-597b-4f34-840c-7883c7179bf5/iso-12251-2011>



COPYRIGHT PROTECTED DOCUMENT

© ISO 2011

All rights reserved. Unless otherwise specified, no part of this publication may be reproduced or utilized in any form or by any means, electronic or mechanical, including photocopying and microfilm, without permission in writing from either ISO at the address below or ISO's member body in the country of the requester.

ISO copyright office
Case postale 56 • CH-1211 Geneva 20
Tel. + 41 22 749 01 11
Fax + 41 22 749 09 47
E-mail copyright@iso.org
Web www.iso.org

Published in Switzerland

Contents

Page

Foreword	iv
1 Scope	1
2 Symbols	1
3 General requirements	2
3.1 Clamp mounting arrangement	2
3.2 Injector guiding dimensions	3
3.3 Concentricity of the nozzle shaft	3
4 Dimensions and tolerances	5
4.1 Type A, clamp mounted CR fuel injectors with straight capnut	5
4.2 Type B, clamp mounted CR fuel injectors with stepped capnut	7
5 Other specifications	9
6 Designation	9

iTeh STANDARD PREVIEW
(standards.iteh.ai)

ISO 12251:2011

<https://standards.iteh.ai/catalog/standards/sist/8007e00a-597b-4f34-840c-7883c7179bf5/iso-12251-2011>

Foreword

ISO (the International Organization for Standardization) is a worldwide federation of national standards bodies (ISO member bodies). The work of preparing International Standards is normally carried out through ISO technical committees. Each member body interested in a subject for which a technical committee has been established has the right to be represented on that committee. International organizations, governmental and non-governmental, in liaison with ISO, also take part in the work. ISO collaborates closely with the International Electrotechnical Commission (IEC) on all matters of electrotechnical standardization.

International Standards are drafted in accordance with the rules given in the ISO/IEC Directives, Part 2.

The main task of technical committees is to prepare International Standards. Draft International Standards adopted by the technical committees are circulated to the member bodies for voting. Publication as an International Standard requires approval by at least 75 % of the member bodies casting a vote.

Attention is drawn to the possibility that some of the elements of this document may be the subject of patent rights. ISO shall not be held responsible for identifying any or all such patent rights.

ISO 12251 was prepared by Technical Committee ISO/TC 22, *Road vehicles*, Subcommittee SC 7, *Injection equipment and filters for use on road vehicles*.

iTeh STANDARD PREVIEW (standards.iteh.ai)

[ISO 12251:2011](https://standards.iteh.ai/catalog/standards/sist/8007e00a-597b-4f34-840c-7883c7179bf5/iso-12251-2011)

<https://standards.iteh.ai/catalog/standards/sist/8007e00a-597b-4f34-840c-7883c7179bf5/iso-12251-2011>

Diesel engines — Clamp mounted CR fuel injectors — Mounting dimensions

1 Scope

This International Standard specifies dimensional requirements for clamp mounted CR fuel injectors and their corresponding cylinder head features in diesel engines.

According to the injector nozzle capnut, the clamp mounted CR fuel injectors can be divided into two types:

- a) Type A, where the nozzle capnut is straight (see Figure 4).
- b) Type B, where the nozzle capnut is stepped (see Figure 5).

Each clamp mounted CR fuel injector type is subdivided by a series of different sizes.

NOTE This differentiation corresponds to the relationship between the two guide diameters of the clamp mounted CR fuel injectors.

ITIH STANDARD PREVIEW
(standards.iteh.ai)

2 Symbols

ISO 12251:2011

For the purposes of this document, the following symbols apply:

D_1 = injector shaft diameter

D_2 = injector upper guide diameter

D_3 = capnut diameter

D_4 = injector lower guide diameter

D_5 = injector nozzle shaft diameter

d_6 = bore for upper guide diameter

d_7 = bore for lower guide diameter

d_8 = bore for nozzle shaft

l_1 = overall injector length

l_2 = distance between sealing face and upper guide diameter of injector

l_3 = overlapping (upper guide diameter/cylinder head)

l_4 = injector clamping width

l_5 = clamp width

l_6 = injector clamping height

l_7 = distance between sealing face and datum B on injector

l_8 = distance between sealing face and datum C on injector

NOTE l_7 and l_8 are dependent on the cylinder head design as agreed between injector manufacturer and customer.

3 General requirements

3.1 Clamp mounting arrangement

A typical clamp mounting arrangement is shown in Figure 1 (schematically).

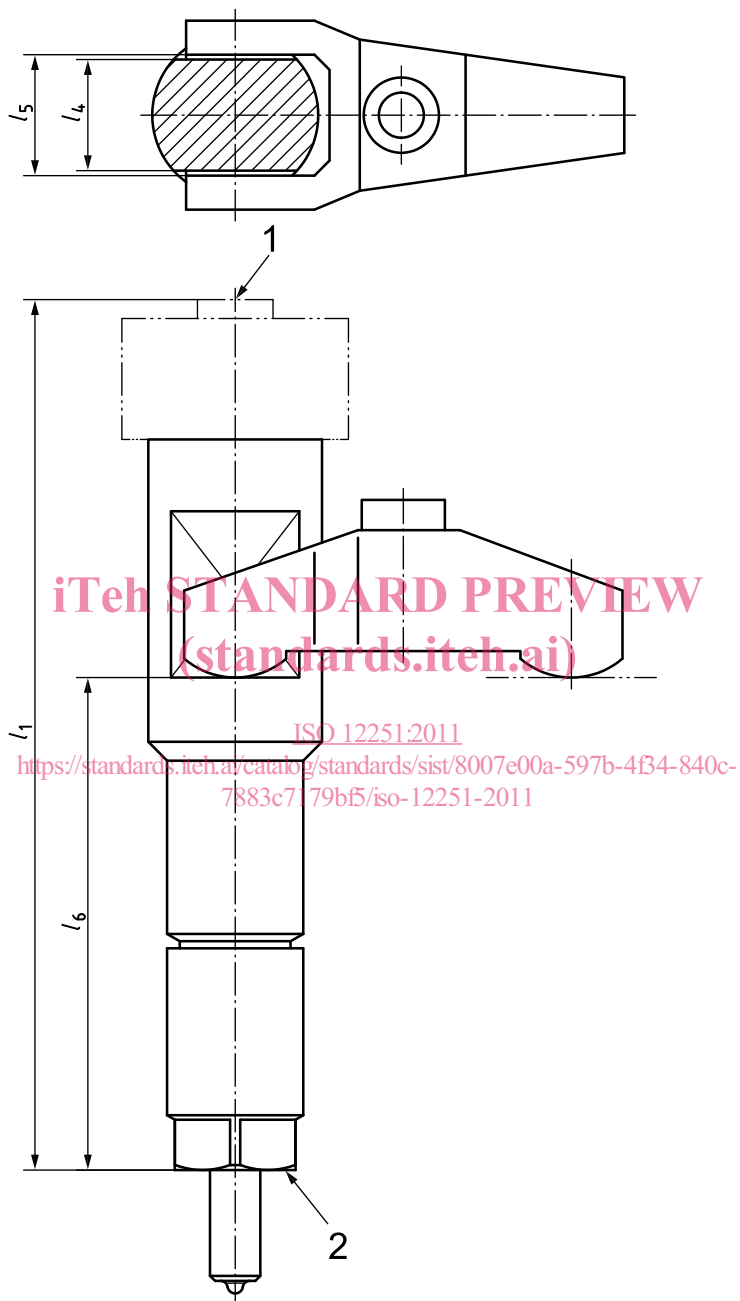

Key

- l_1 overall injector length
- l_6 injector clamping height
- 1 top of injector (e.g. hydraulic connection)
- 2 injector sealing face

NOTE The injector clamping height varies depending on engine application and is agreed between manufacturer and customer.

Figure 1 — Typical injector clamp mounting arrangement

3.2 Injector guiding dimensions

The important injector guiding dimensions are shown in Figure 2 (schematically).

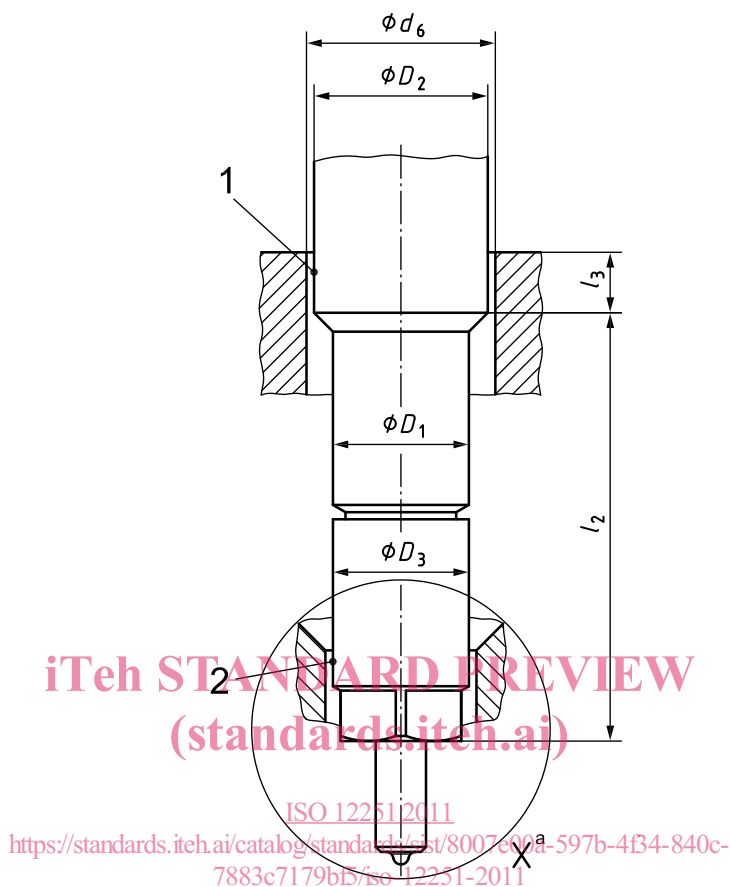

Key

- l_3 overlapping at upper guide (upper guide diameter/cylinder head)
- 1 upper guide
- 2 lower guide
- ^a See Figures 4 and 5 for details.

Figure 2 — Typical injector guiding arrangement

3.3 Concentricity of the nozzle shaft

The determination of the concentricity, ϕ_c , of the nozzle shaft relative to the axis of the two guide diameters, ϕD_2 and ϕD_4 , is shown in Figure 3 (schematically).

The concentricity, ϕ_c , is the result of the form and position tolerances of the two guide diameters, based on the production conditions, and is specified by the injector manufacturer by simultaneously taking into consideration the compatibility with the dimensional structure of the cylinder head.

The purpose of this concentricity is to determine the position of the nozzle shaft (centre axis of ϕD_5) related to the cylinder head bore, ϕd_8 ; this is important in order to ensure that the nozzle shaft does not interfere with the bore in the cylinder head (see Tables 2 and 4, table footnote c, and Figure 3, key item c).

Requirements for measurement of the concentricity, $\varnothing t$:

- the datum B position (l_7) shall be agreed between injector manufacturer and customer;
- the datum C position (l_8) depends on the distance between the two guides and the overlapping (see Figure 2: l_2 and l_3) and shall be agreed between injector manufacturer and customer.

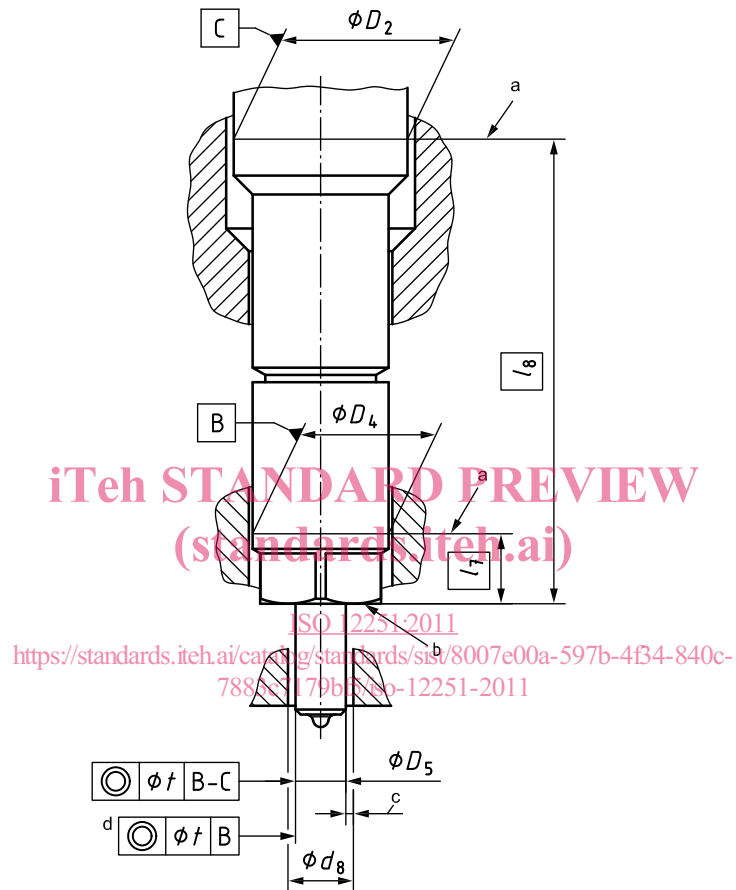

- a Datum positions (at the two guide diameters).
- b Injector sealing face.
- c Required gap between the nozzle shaft and the bore in the cylinder head (no interference).
- d For single guide diameter injector types.

Figure 3 — Concentricity $\varnothing D_5$ of the nozzle shaft

4 Dimensions and tolerances

4.1 Type A, clamp mounted CR fuel injectors with straight capnut

Figure 4 shows the injector and nozzle dimensions and the corresponding cylinder head dimensions.

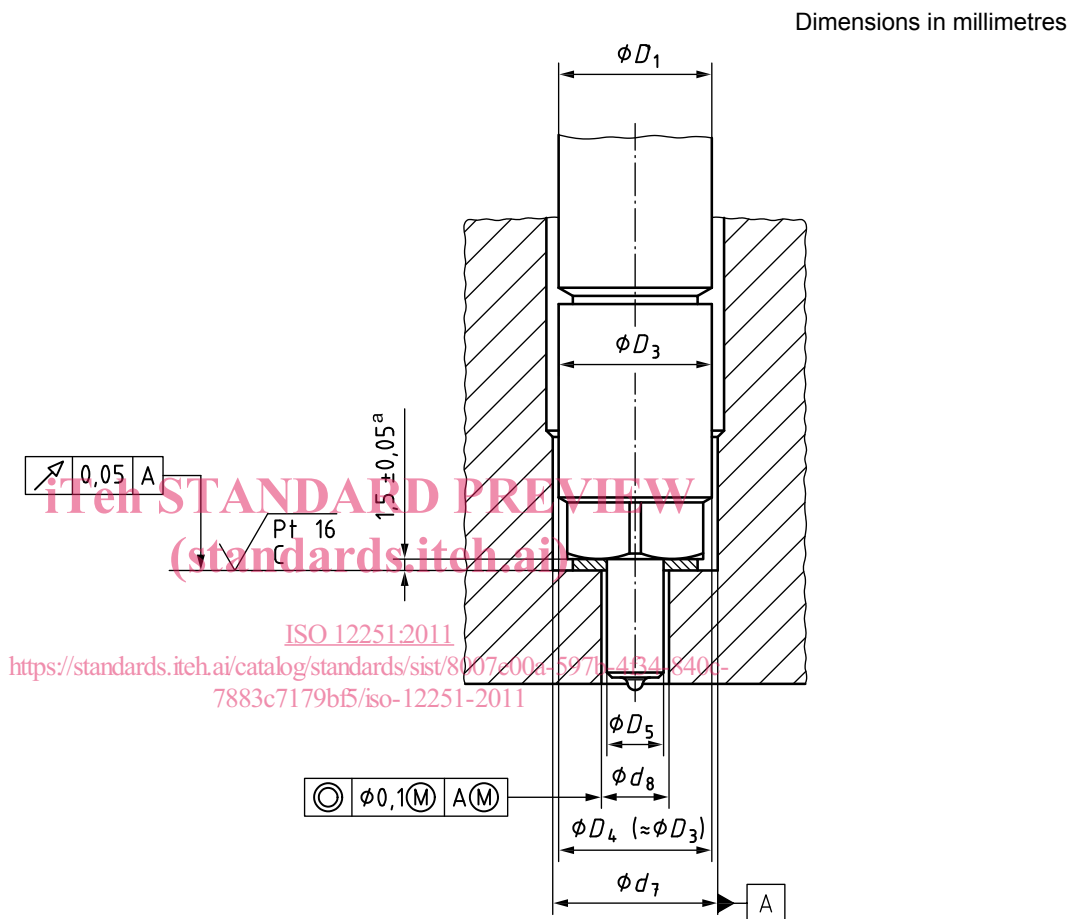

^a Sealing washer thickness may vary depending on engine manufacturer's requirements.

Figure 4 — Injector and cylinder head dimensions, Type A (detail X of Figure 2)