



Designation: D 3930 – 93a (Reapproved 1999)^{e1}

Standard Specification for Adhesives for Wood-Based Materials for Construction of Manufactured Homes¹

This standard is issued under the fixed designation D 3930; the number immediately following the designation indicates the year of original adoption or, in the case of revision, the year of last revision. A number in parentheses indicates the year of last reapproval. A superscript epsilon (ϵ) indicates an editorial change since the last revision or reapproval.

^{e1} NOTE—Keywords were added in April 1999.

INTRODUCTION

This specification provides a standard for measuring and evaluating the performance of adhesives that will be used in joints of wood-based materials in constructing manufactured homes. This specification has two parts: Part I contains the requirements necessary for an adhesive to conform to this specification; and Part II provides test methods by which the performance of the adhesives will be measured. A classification system is provided that groups adhesives according to resistance to deformation under load, resistance to moisture, and gap-filling ability. Minimum test values have been specified for certain properties of durability, while other property requirements are left open-ended. The test methods used to obtain these values reflect adverse exposure and stress conditions that exist during the construction, transit, and use of manufactured homes. By using values published from these prescribed test methods, the design engineer can select an adhesive that best meets the requirements of a specific adhesive application.

The test methods used in this specification were developed predominantly from existing ASTM standards, while others came from standards that have been generally accepted for years. Some test methods were more recently developed. In most instances, only parts of these standards have been used in this specification. Since no precision and bias statements are available from the original test methods, none can be made for this specification at this time.

PART I— REQUIREMENTS

<https://standards.iteh.ai/catalog/standards/sist/07f161fc-7c7a-4639-8495-0b439d9a7d3a/astm-d3930-93a1999e1>

1. Scope

1.1 This specification provides the means to measure and evaluate the performance of adhesives for structural or semi-structural bonding of wood-to-wood in manufactured homes. Wood as used in this specification includes lumber, plywood, particleboard, gypsum board, and all materials having wood-based surfaces at the bondline. This specification does not cover other adhesives used in manufactured homes such as adhesives for carpet, floor tile, ceramic fixtures, plastic laminates, trim and millwork, and similar nonstructural applications.

1.1.1 The performance of the adhesives is measured in the following tests:

Number	Test	Section
1	Low Temperature	15
2	Dry Lumber	16
3	Gap-Filling	17
4	High Temperature	18
5	Type 3 Qualification	19
6	Type 2 Qualification	20
7	Aging, Film Oxidation	21
8	Aging, Bond Oxidation	22
9	Resistance to Deformation, Creep	23
10	Mold	24
11	Type 1 Qualification	25

1.2 *This standard does not purport to address all of the safety concerns, if any, associated with its use. It is the responsibility of the user of this standard to establish appropriate safety and health practices and determine the applicability of regulatory limitations prior to use.*

¹ This specification is under the jurisdiction of ASTM Committee D-14 on Adhesives and is the direct responsibility of Subcommittee D14.70 on Construction Adhesives.

Current edition approved Dec. 15, 1993. Published February 1994. Originally published as D 3930 – 80. Last previous edition D 3930 – 90a.

2. Referenced Documents

2.1 ASTM Standards:

- A 269 Specification for Seamless and Welded Austenitic Stainless Steel Tubing for General Service²
- A 376/A376M Specification for Seamless Austenitic Steel Pipe for High-Temperature Central-Station Service²
- D 905 Test Method for Strength Properties of Adhesive Bonds in Shear by Compression Loading³
- D 1002 Test Method for Apparent Shear Strength of Single-Lap-Joint Adhesively Bonded Metal Specimens by Tension Loading (Metal-to-Metal)³
- D 2294 Test Method for Creep Properties of Adhesives in Shear by Tension Loading (Metal-to-Metal)³
- D 2339 Test Method for Strength Properties of Adhesives in Two-Ply Wood Construction in Shear by Tension Loading³
- D 3110 Specification for Adhesives Used in Laminate Joints for Nonstructural Glued Lumber Products³
- D 3632 Practice for Accelerated Aging of Adhesive Joints by the Oxygen-Pressure Method³
- D 3931 Test Method for Determining Strength of Gap-Filling Adhesive Bonds in Shear by Compression Loading³
- D 4300 Test Methods for Ability of Adhesive Films to Support or Resist the Growth of Fungi³

3. Terminology

3.1 *Definitions*—Many terms in this specification are defined in Terminology D 907.

3.1.1 *creep, n*—in an adhesive, the time-dependent increase in strain resulting from a sustained stress.

3.1.2 *gap-filling adhesive, n*—an adhesive capable of forming and maintaining a bond between surfaces that are not close-fitting.

3.1.2.1 *Discussion*—Close fitting is relative to a given material and industry; for example, standards in construction differ from standards in electronics. Some adhesives will bond by bridging without completely filling the gap; others by filling the gap completely.

3.2 Definitions of Terms Specific to This Standard:

3.2.1 *manufactured home*⁴—a structure, transportable in one or more sections which in the traveling mode is 8 body feet or more in width or 40 body feet or more in length or when erected on site, is 320 or more square feet and which is built on a permanent chassis and designed to be used as a dwelling with or without a permanent foundation when connected to the required utilities, and includes the plumbing, heating, air-conditioning, and electrical systems contained therein. Calculations used to determine the number of square feet in a structure will be based on the structure's exterior dimensions measured at the largest horizontal projections when erected on

site. These dimensions will include all expandable rooms, bay windows, cabinets, and other projections containing interior space.

3.2.2 *semi-structural adhesive*—an adhesive capable of transferring required loads between adherends and which deforms a maximum of 0.050 in. (1.27 mm) under static load when tested in accordance with Test 9, Section 23.

3.2.3 *structural adhesive*—an adhesive capable of transferring required loads between adherends and which deforms a maximum of 0.006 in. (0.15 mm) under static load when tested in accordance with Test 9, Section 23.

3.2.4 *total deformation*—the total dimensional change with time of a material under constant load, and consisting of the initial instantaneous elastic or rapid deformation and the slower time dependent deformation or creep.

3.2.5 *Type 1 adhesive*—an adhesive that will retain its bond integrity when the joint is repeatedly wetted and dried.

3.2.6 *Type 2 adhesive*—an adhesive intended for use in protected locations but that will maintain its bond integrity when the bond is subjected to occasional wetting.

3.2.7 *Type 3 adhesive*—an adhesive intended for use in interior locations, but that will maintain its bond integrity during conditions of high humidity.

NOTE 1—The following ASTM standards may be referred to for other terms used in this specification: D 9, Terms Relating to Timber; D 907, Terms Relating to Adhesives; D 1165, Nomenclature of Domestic Hardwoods and Softwoods; E 6, Terms Relating to Methods of Mechanical Testing; and E 41, Terms Relating to Conditioning.

4. Classification

4.1 Adhesives shall be classified as follows (see Table 1):

4.1.1 By resistance to deformation as:

4.1.1.1 Group A, Structural; or Group B, Semistructural,

4.1.2 By resistance to water and water vapor as:

4.1.2.1 Type 1, Type 2, or Type 3, and

4.1.3 By gap-filling ability.

4.1.3.1 Those adhesives tested in accordance with Test 3, Section 17, shall carry the designation G/F.

5. Significance and Use

5.1 *Shear Strength*—This specification requires determining ultimate shear strength of adhesive bonds under a variety of conditions of assembly and service.

5.2 *Gap-Filling Ability*—Gap-filling adhesives must be capable of maintaining a bond between construction members whose faying surfaces are not closely matched. The gap-filling ability and shear strength are determined for 1/16-in. (1.6-mm) gap between members. The adhesive manufacturer may qualify

TABLE 1 Tests Required for Group A (Structural), and Group B (Semi-Structural) Adhesives

Type	Recommended Use	Tests Required (Test Number)
1 ^A	interior-exterior	1, 2, 4, 7 (or 8), 9, 10, 11 ^B
2 ^A	interior-weather protected	1, 2, 4, 6, 7 (or 8), 9, 10
3 ^A	interior	1, 2, 4, 5, 7 (or 8), 9, 10

^A To qualify as G/F (gap-filling), adhesives must be tested by Test 3, Section 17.

^B The exposure and testing conditions for the cyclic-boil and vacuum-pressure tests, described in 10.2.1.1 and 10.2.1.2 of Specification D 3110, shall apply to Test 11.

² Annual Book of ASTM Standards, Vol 01.01.

³ Annual Book of ASTM Standards, Vol 15.06.

⁴ This definition conforms to that of the U.S. Department of Housing and Urban Development (Manufactured Housing Construction and Safety Standards Act of 1974 as amended in proposed rules in the Federal Register, Vol 48, No. 152, Aug. 7, 1981, pp. 40498 to 40500).

larger gap-filling abilities, provided the adhesive is tested and shear values are provided for the greater dimension.

5.3 Total Deformation Resistance—The total deformation of an adhesive under static load is used to establish the structural grouping for the adhesive. The adhesive manufacturer determines the maximum shear stress below which the adhesive will perform structurally and semi-structurally in accordance with the description of terms used in this specification, and also reports the stress used for testing the adhesive. To ensure that the total deformation is approaching a zero rate of increase, no more than 25 % of the deformation is allowed to occur during the last half of the test period.

5.4 Moisture and Temperature Limitations During Fabrication—Adhesives may be used under a wide variety of moisture and temperature conditions. To ensure reliable performance under test conditions, adhesive shear strength is determined for specified adverse moisture and temperature conditions.

5.5 High- and Low-Temperature Resistance—The adhesive is tested at high and low temperatures to determine whether extremes in temperature would cause problems in bonding.

5.6 Moisture Resistance—The adhesive is tested at three levels of exposure. Adhesive durability for Type 1 is determined by exposure to a cyclic boil and a vacuum-pressure test. For Type 2, a vacuum-soak is used. For Type 3, a humidity test at elevated temperature is used.

5.7 Aging, Oxidation Resistance—To ensure that the adhesive does not become embrittled or substantially deteriorate with age, the adhesive film or tensile lap shear specimens bonded with the adhesive, are exposed to pure oxygen at an elevated temperature and pressure.

5.8 Mold Resistance— Conditions fostering the growth of mold are encountered in the structural spaces of walls, floors, and roofs. The adhesive is tested against three species of mold commonly present on wood, either as separate tests or as a single test with a mixed culture of the mold species.

6. Test Methods

6.1 The tests required for compliance with this specification are given in Table 1.

6.2 The compliance criteria for Tests 1 through 11, Sections 15-25, are given in Table 2.

6.2.1 For Tests 1 through 6, Sections 15-20, and Test 11, Section 25, only test results must be reported.

6.2.1.1 Type 1 adhesives in Group A or Group B shall be evaluated on the basis of test specimens prepared in accordance with Sections 13 and 25, and subsequently exposed and tested in accordance with the procedures for the cyclic-boil and vacuum-pressure tests specified for wet-use adhesives in 10.2.1.1 and 10.2.1.2 of Specification D 3110. The only exception is that average strength values shall be reported in pounds-force per square inch (or megapascals).

6.2.2 Minimum performance levels are given for Test 7, Section 21; Test 8, Section 22; and Test 10, Section 24.

6.2.3 For Test 9, Section 23, an evaluation shall be made on the basis of the loads used to test the adhesive for total deformation.

7. Sampling

7.1 Take a representative sample from each lot of adhesive to be tested.

7.1.1 For liquid or paste adhesives, the sample from each lot shall not be less than 1 qt (946 mL).

7.1.2 For adhesives consisting of more than one part, take a sufficient sample of each part in order to prepare not less than 2 lb (908 g) of adhesive at the time of use.

7.1.3 For dry adhesives, the sample from each lot shall not be less than 2 lb (908 g).

7.2 Consult the adhesive manufacturer as to proper packing and handling of the sample.

8. Retest and Rejection

8.1 If the results of any initial test do not conform to the requirements prescribed in this specification, that test shall be repeated on two additional sets of specimens from a new sample of the same lot of adhesive, each of which shall conform to the requirements specified. If either of these two additional sets of specimens fail to meet the requirements, the lot or batch of material shall be rejected.

TABLE 2 Performance Requirements

Test Number	Section Number	Test Description	Requirements
		Conditions of Application:	
1	15	low temperature	shear strength ^A
2	16	dry lumber	shear strength ^A
3	17	gap-filling	shear strength ^A
		Measurements of Durability:	
4	18	high temperature	shear strength ^A
5	19	Type 3 Qualification	shear strength ^A
6	20	Type 2 Qualification	shear strength ^A
7	21	aging, film oxidation	one, 180° bend around a ¼ -in. (6.4-mm) mandrel with none of the 5 specimens breaking
8	22	aging, bond oxidation	maintain 50 % of original shear strength
9	23	resistance to deformation (creep)	Group A: 0.006 in. (0.152 mm) ^B Group B: 0.050 in. (1.27 mm) ^B
10	24	mold	no growth after 14 days
11	25	Type 1 Qualification	shear strength ^A

^A Post average shear strength.

^B Maximum allowable total deformation under given load and conditions of 23.2.2.

9. Certification

9.1 Upon request of the purchaser in the contract or order, a manufacturer's certification that the adhesive was manufactured in conformance with this specification shall be furnished at the time of shipment.

10. Packaging

10.1 The material shall be packaged in standard commercial containers, as required by Department of Transportation regulations, if applicable. The containers shall be so constructed as to ensure acceptance by common or other carrier for safe transportation at the lowest rate to the point of delivery, unless otherwise specified in the contract or order. The container shall provide suitable protection of the contents to ensure that the adhesive is not spoiled due to exposure to the elements.

11. Marking

11.1 Shipping containers or cases shall be marked with the following information:

11.1.1 Manufacturer's name, product code number, batch lot number, and date of manufacture.

11.1.2 Group and type of adhesive as classified in Table 1, including use of the symbol G/F if the adhesive is gap-filling.

11.1.3 Special handling instructions during product transfer.

11.1.4 Special precautions required because of product toxicity, flammability, or such information pertinent to the proper handling and storage of the product.

12. Adhesive Manufacturer's Instructions

12.1 The adhesive manufacturer shall provide instructions for the proper preparation of the adhesive and proper use with the material to be bonded. Such instructions shall indicate:

12.1.1 The moisture content range of the materials being bonded at the time of bonding.

12.1.2 Complete mixing directions for the adhesives.

12.1.3 Conditions for application of the adhesive including the rate of spread or thickness of film, bead size, number of coats to be applied, temperature of application, whether to be applied to one or both surfaces, and the condition of drying where more than one coat is required.

12.1.4 Adhesive open and closed assembly time over the ambient temperature and humidity range specified.

12.1.5 Curing conditions, including the amount of pressure to be applied, if any, whether this pressure may be provided by nails or staples, or both, or by other means, the length of time under pressure and the temperature of the assembly when under pressure. It should be stated whether this temperature is that of the glue line, or of the atmosphere at which the assembly is to be maintained.

12.1.6 *Storage Conditions Prior to Use*—Instructions shall include data on shelf life and storage under various conditions.

PART II—TEST METHODS

13. Test Assemblies for Tests 1 through 6 and 11

13.1 *Materials*—Use the following materials for the preparation of test assemblies for Tests 1 through 6 and 11.

13.1.1 *Plywood*—Use $\frac{5}{8}$ -in. (16-mm) commercial softwood plywood of underlayment grade with exterior adhesive,

or sanded exterior-grade plywood (Group I species). To help ensure uniformity of the bonding surface, select plywood having all sapwood or all heartwood in the face veneer—not both (Note 2). Also check the face veneer to see that lathe checks do not appear in the bonding surface. The plywood must be free of splits, patches, core voids, knots, and knot holes in the bonding area. The plywood must be flat within $\frac{1}{16}$ in. (2 mm), that is, the maximum permissible bow for a 16-in. (406-mm) length of plywood shall be $\frac{1}{16}$ in. (2 mm). Bowed plywood may be used only if it meets the limitation above and if the convexity occurs on the bottom surface that contacts the lumber.

13.1.2 *Framing Lumber*—Use 2-in. (51-mm) (nominal) Douglas-fir or southern pine lumber that is clear and dry. Select lumber that is all sapwood or all heartwood, except as noted for southern pine (Note 2). The lumber must have been knife-planed on all four surfaces at the factory, or so prepared in the laboratory. The lumber must be free of splits, knots, knot holes, bark, and pitch on the surface being bonded.

NOTE 2—Only the sapwood of loblolly, slash, longleaf, and shortleaf pine may be used.

13.1.3 *Adhesive*—Use the adhesive in accordance with the manufacturer's instructions.

13.1.4 *Nails*—In preparing test joint assemblies, use six-penny (2.1 in. (53 mm) in length) double-headed scaffold nails to fasten plywood and lumber together (Note 3). If these are not available, use eight-penny (2.6 in. (66 mm) in length) double-headed nails. If the nail points are a problem when they protrude from the assembly, cut them to a minimum of 2 in. (51 mm) in length, as measured from the cut point to the inside head.

NOTE 3—Six-penny double-headed nails usually are not stocked in retail hardware stores. However, they are manufactured and may be obtained at some wholesale building supply dealers such as Georgia-Pacific Corp.

13.1.5 *Spacers*—For the gap-filling test, separate the plywood and lumber with spacers $\frac{1}{4}$ in. (6 mm) wide, $\frac{1}{16}$ in. (1.6 mm) thick, and 4 in. (102 mm) long (Note 4).

NOTE 4—TFE-fluorocarbon sheet is suggested for use as spacers.

13.2 Clean the surfaces of wood to be bonded so they are free from oil, dust, and other contaminants that would be detrimental to satisfactory bonding.

13.3 Cut the lumber and plywood to the required size as shown in Fig. 1 or Fig. 2 (Note 5). If the lumber must be reduced in height, retain at least one mill-finished surface as the surface to be bonded. If the lumber must be reduced in width to achieve a maximum $1\frac{1}{2}$ -in. (38-mm) dimension, plane both sides in equal amounts.

13.4 Pre-drill the plywood and lumber to receive nails as shown in Fig. 1 or Fig. 2. Drill to a depth of 1 in. (25 mm) through the plywood and into the lumber. Use a No. 46 (diameter 0.081 in. (2.05 mm)) drill for the six-penny nail and a No. 43 (diameter 0.089 in. (2.26 mm)) drill for the eight-penny nail.

13.5 *Conditioning of Materials Before Bonding*:

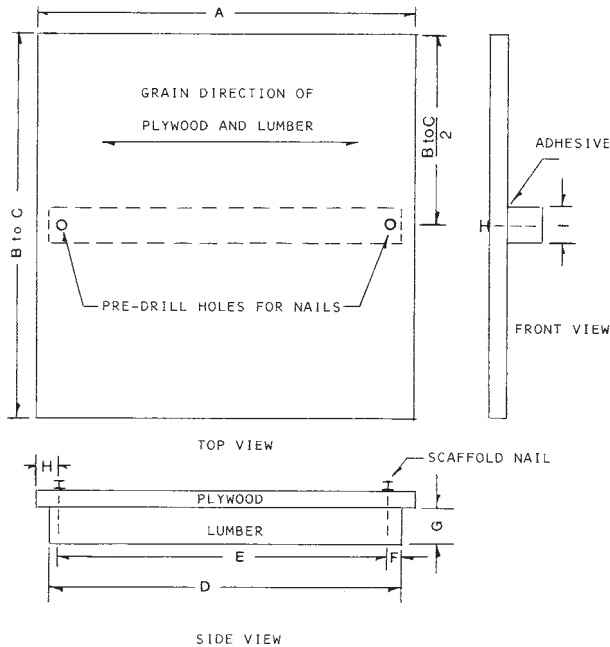

Table of Dimensions

	in. (mm)	
	Dimension	Tolerance
A	15¾ (400)	⅛ (3)
B	5½ (140)	...
C	16 (406)	...
D	15 (381)	⅛ (3)
E	13 (330)	⅛ (3)
F	1 (25)	⅛ (3)
G	1½ (38) min	⅛ (2)
H	1⅝ (33)	⅛ (2)
J	1½ (38) max	⅛ (2)

FIG. 1 Test Assembly

13.5.1 Prepare the adhesive in accordance with the manufacturer's instructions, or if ready to use, condition at 75 ± 5.0°F (23.9 ± 2.8°C) for a period of 48 h prior to use.

13.5.2 Condition the lumber and plywood to an EMC (equilibrium moisture content) of 10 to 12 % in accordance with the schedule in Appendix X2, before proceeding with the conditioning schedules of Table 3 for Tests 1 through 6.

13.6 *Number of Test Assemblies*—Prepare three test assemblies as shown in Fig. 1 or Fig. 2, using positioning jigs shown in Fig. 2 or Fig. 3, for each set of test conditions within each test (Note 5). Cut eight specimens from each of the assemblies.

NOTE 5—Fig. 2 shows the design of an alternative positioning jig and test assembly that allows three assemblies to be made from a single 6½ by 16-in. (165 by 406-mm) piece of plywood. This alternative positioning jig may be used for combinations of assemblies for Tests 3, 4, 5, 6, and 11 which require the same lumber conditioning. Do not combine assemblies for Test 1 or Test 2 with assemblies for other test numbers in the same jig.

13.7 *General Procedure for Preparation of Test Assemblies:*

13.7.1 Set nails in the plywood through the predrilled holes so that tips of the nails extend ⅜ in. (5 mm) beyond the bottom surface of the plywood. Apply adhesive along the mill-finished surface of the lumber, such that it extends from one predrilled hole to the other, but not beyond. Apply a single bead of adhesive just large enough to give 100 % coverage of

the lumber surface, as evidenced by squeeze-out. If it is necessary to apply the adhesive outside of the lumber conditioning chamber (Tests 1 and 2), remove only one piece of lumber at a time in order to perform the operation before the temperature of the lumber changes appreciably. Apply the adhesive; then condition the lumber with adhesive applied for the open assembly time recommended by the adhesive manufacturer. Consult Table 3 for temperature and humidity conditions for each test number during this open assembly time. Then position the plywood on the adhesive-coated surface and allow it to stand for the recommended closed assembly time (same temperature and humidity conditions). Nail in place as shown in Fig. 1, with the aid of a positioning jig as shown in Fig. 2 or Fig. 3. Drive the top of the lower head of the scaffold nail so that it is flush with the surface of the plywood. Do not clamp or apply pressure other than supplied by nailing. Consult Table 3 or the individual test procedures in Sections 15-20 and Section 25 for time, temperature, and humidity conditions to be used for the period of cure.

13.7.2 At the end of the curing cycle, take assemblies to a work area maintained at 75 ± 5°F (23.9 ± 2.8°C) and 50 ± 10 % relative humidity. Remove the nails, trim excess lumber and plywood, and cut eight block shear specimens from each assembly as shown in Figs. 4 and 5. Before machining the laminations, remove adhesive squeeze-out from the sides of the assembly.

14. *Specimens for Tests 8 and 9*

14.1 See Section 22 for instructions on preparation of test specimens for Test 8, and Section 23 for Test 9.

15. *Test 1—Low Temperature*

15.1 *Preparation of Specimens:*

15.1.1 Condition the lumber and plywood, previously brought to 10 to 12 % EMC, for 48 h at the temperature selected by the adhesive manufacturer as the minimum temperature for application of the adhesive. Control the temperature within ±5°F (2.8°C). The relative humidity may be uncontrolled.

15.1.2 Prepare or condition the adhesive as instructed in 13.5.1.

15.1.3 Prepare three test assemblies in accordance with the general instructions in 13.7 and Fig. 1 and Fig. 3, or Fig. 2, using the adhesive manufacturer's recommendations as to open and closed assembly times.

15.1.4 Cure for 28 days at the minimum temperature previously selected by the adhesive manufacturer. Control the temperature within ±2.5°F (1.4°C). The relative humidity may be uncontrolled.

15.1.5 Remove from curing area and cut eight specimens from each test assembly (24 specimens) in accordance with 13.7.2 and Figs. 4 and 5.

15.1.6 Condition the specimens for 15 h at the previously selected minimum temperature within ±2.5°F (1.4°C).

15.2 *Testing of Specimens:*

15.2.1 Remove the test specimens one at a time from the conditioning chamber and test while still at that temperature.

15.2.2 Test the specimens for shear strength by compression loading in a testing machine in a work area at 75 ± 5°F (23.9

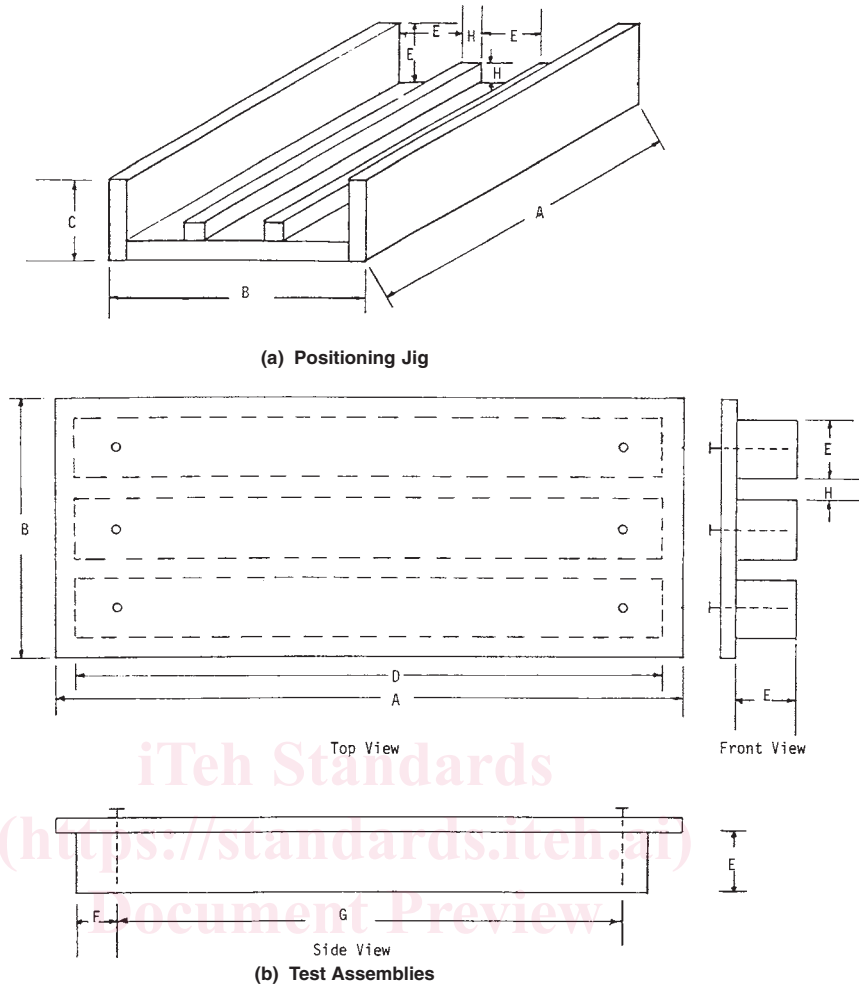

(a) Positioning Jig

(b) Test Assemblies

Table of Dimensions

	in. (mm)	
	Dimension	Tolerance
A	15¾ (400)	⅛ (3)
B	6½ (165)	⅛ (3)
C	2 (51)	⅙ (2)
D	15 (381)	⅛ (3)
E	1½ (38)	⅙ (2)
F	1 (25)	⅛ (3)
G	13 (330)	⅛ (3)
H	½ (13)	⅙ (2)

FIG. 2 Alternative Positioning Jig and Test Assemblies

± 2.8°C) and 50 ± 10 % relative humidity. A shearing tool described in Method D 905 is recommended for this test, but other equipment may be used as long as the speed can be controlled and the shearing tool is self-aligning. Use a loading rate of 0.2 in. (5 mm)/min. Read the ultimate load to the nearest 1 lbf (or 1 N) for each of the 24 specimens.

15.3 *Reporting*—Report the shear strengths for each specimen in pounds-force per square inch (or megapascals) and percent wood failure, together with the overall average of the 24 specimens for each condition.

16. Test 2—Dry Lumber

16.1 Preparation of Specimens:

16.1.1 Condition the lumber and plywood, previously brought to 10 to 12 % EMC, for 7 days at 100 ± 5°F (37.8 ± 2.8°C) and 30 ± 10 % relative humidity to a MC (moisture content) maximum of 8 %.

16.1.2 Prepare or condition the adhesive as instructed in 13.5.1.

16.1.3 Prepare three test assemblies in accordance with the general instructions in 13.7 and Fig. 1 and Fig. 3, or Fig. 2, using the adhesive manufacturer's recommendations as to open and closed assembly times.

16.1.4 Cure the assemblies for 28 days at 100 ± 5°F (37.8 ± 2.8°C) and 30 ± 10 % relative humidity.