**Thermal insulating products for building
applications — Determination of bending
behaviour**

*Produits isolants thermiques destinés aux applications du bâtiment —
Détermination du comportement en flexion*

iTeh STANDARD PREVIEW
(standards.iteh.ai)

[ISO 12344:2010](https://standards.iteh.ai/catalog/standards/sist/30521ff1-65ad-4f1a-b0a6-7b1c82671852/iso-12344-2010)

<https://standards.iteh.ai/catalog/standards/sist/30521ff1-65ad-4f1a-b0a6-7b1c82671852/iso-12344-2010>



PDF disclaimer

This PDF file may contain embedded typefaces. In accordance with Adobe's licensing policy, this file may be printed or viewed but shall not be edited unless the typefaces which are embedded are licensed to and installed on the computer performing the editing. In downloading this file, parties accept therein the responsibility of not infringing Adobe's licensing policy. The ISO Central Secretariat accepts no liability in this area.

Adobe is a trademark of Adobe Systems Incorporated.

Details of the software products used to create this PDF file can be found in the General Info relative to the file; the PDF-creation parameters were optimized for printing. Every care has been taken to ensure that the file is suitable for use by ISO member bodies. In the unlikely event that a problem relating to it is found, please inform the Central Secretariat at the address given below.

iTeh STANDARD PREVIEW
(standards.iteh.ai)

ISO 12344:2010

<https://standards.iteh.ai/catalog/standards/sist/30521ff1-65ad-4f1a-b0a6-7b1c82671852/iso-12344-2010>



COPYRIGHT PROTECTED DOCUMENT

© ISO 2010

All rights reserved. Unless otherwise specified, no part of this publication may be reproduced or utilized in any form or by any means, electronic or mechanical, including photocopying and microfilm, without permission in writing from either ISO at the address below or ISO's member body in the country of the requester.

ISO copyright office
Case postale 56 • CH-1211 Geneva 20
Tel. + 41 22 749 01 11
Fax + 41 22 749 09 47
E-mail copyright@iso.org
Web www.iso.org

Published in Switzerland

Contents

Page

Foreword	iv
Introduction.....	v
1 Scope	1
2 Normative references	1
3 Terms and definitions	1
4 Principle.....	2
5 Apparatus	2
6 Test specimens.....	4
6.1 Dimensions of test specimens.....	4
6.2 Number of test specimens.....	4
6.3 Preparation of test specimens	4
6.4 Conditioning of test specimens	4
7 Procedure	5
7.1 Test conditions.....	5
7.2 Test procedure.....	5
8 Calculation and expression of results.....	5
8.1 General	5
8.2 Bending strength.....	5
8.3 Bending stress and deflection	6
9 Accuracy of measurement.....	7
10 Test report.....	7

Foreword

ISO (the International Organization for Standardization) is a worldwide federation of national standards bodies (ISO member bodies). The work of preparing International Standards is normally carried out through ISO technical committees. Each member body interested in a subject for which a technical committee has been established has the right to be represented on that committee. International organizations, governmental and non-governmental, in liaison with ISO, also take part in the work. ISO collaborates closely with the International Electrotechnical Commission (IEC) on all matters of electrotechnical standardization.

International Standards are drafted in accordance with the rules given in the ISO/IEC Directives, Part 2.

The main task of technical committees is to prepare International Standards. Draft International Standards adopted by the technical committees are circulated to the member bodies for voting. Publication as an International Standard requires approval by at least 75 % of the member bodies casting a vote.

Attention is drawn to the possibility that some of the elements of this document may be the subject of patent rights. ISO shall not be held responsible for identifying any or all such patent rights.

ISO 12344 was prepared by Technical Committee ISO/TC 163, *Thermal performance and energy use in the built environment*, Subcommittee SC 1, *Test and measurement methods*.

ISO 12344 is based on EN 12089:1997, prepared by Technical Committee CEN/TC 88, *Thermal insulating materials and products*. However,

iTeh STANDARD PREVIEW
(standards.iteh.ai)

- 6.4, Conditioning of the test specimens, [ISO 12344:2010](#)
- 7.1, Test conditions, and <https://standards.iteh.ai/catalog/standards/sist/30521ff1-65ad-4fla-b0a6-7b1c82671852/iso-12344-2010>
- Clause 10, Test report,

have been modified to reflect the conditions for tropical countries.

Introduction

This International Standard is based on EN 12089:1997, prepared by Technical Committee CEN/TC 88, *Thermal insulating materials and products*, which has been amended by ISO/TC 163/SC 1 with reference to conditioning and test conditions in tropical countries.

This International Standard is one of a series of documents specifying test methods, based on existing European Standards, that are being adopted by ISO. This “package” of standards includes the following group of interrelated documents.

International Standard	Title	Respective EN standard
ISO 12344	<i>Thermal insulating products for building applications — Determination of bending behaviour</i>	EN 12089
ISO 12968	<i>Thermal insulation products for building applications — Determination of the pull-off resistance of external thermal insulation composite systems (ETICS) (foam block test)</i>	EN 13495
ISO 29465	<i>Thermal insulating products for building applications — Determination of length and width</i>	EN 822
ISO 29466	<i>Thermal insulating products for building applications — Determination of thickness</i>	EN 823
ISO 29467	<i>Thermal insulating products for building applications — Determination of squareness</i>	EN 824
ISO 29468	<i>Thermal insulating products for building applications — Determination of flatness</i>	EN 825
ISO 29469	<i>Thermal insulating products for building applications — Determination of compression behaviour</i>	EN 826
ISO 29470	<i>Thermal insulating products for building applications — Determination of the apparent density</i>	EN 1602
ISO 29471	<i>Thermal insulating products for building applications — Determination of dimensional stability under constant normal laboratory conditions (23 °C/50 % relative humidity)</i>	EN 1603
ISO 29472	<i>Thermal insulating products for building applications — Determination of dimensional stability under specified temperature and humidity conditions</i>	EN 1604
ISO 29764	<i>Thermal insulating products for building applications — Determination of deformation under specified compressive load and temperature conditions</i>	EN 1605
ISO 29765	<i>Thermal insulating products for building applications — Determination of tensile strength perpendicular to faces</i>	EN 1607
ISO 29766	<i>Thermal insulating products for building applications — Determination of tensile strength parallel to faces</i>	EN 1608
ISO 29767	<i>Thermal insulating products for building applications — Determination of short-term water absorption by partial immersion</i>	EN 1609
ISO 29768	<i>Thermal insulating products for building applications — Determination of linear dimensions of test specimens</i>	EN 12085
ISO 29769	<i>Thermal insulating products for building applications — Determination of behaviour under point load</i>	EN 12430

ISO 12344:2010(E)

ISO 29770	<i>Thermal insulating products for building applications — Determination of thickness for floating-floor insulating products</i>	EN 12431
ISO 29771	<i>Thermal insulating materials for building applications — Determination of organic content</i>	EN 13820
ISO 29803	<i>Thermal insulation products for building applications — Determination of the resistance to impact of external thermal insulation composite systems (ETICS)</i>	EN 13497
ISO 29804	<i>Thermal insulation products for building applications — Determination of the tensile bond strength of the adhesive and of the base coat to the thermal insulation material</i>	EN 13494
ISO 29805	<i>Thermal insulation products for building applications — Determination of the mechanical properties of glass fibre meshes</i>	EN 13496

iTeh STANDARD PREVIEW (standards.iteh.ai)

[ISO 12344:2010](https://standards.iteh.ai/catalog/standards/sist/30521ff1-65ad-4fla-b0a6-7b1c82671852/iso-12344-2010)

<https://standards.iteh.ai/catalog/standards/sist/30521ff1-65ad-4fla-b0a6-7b1c82671852/iso-12344-2010>

Thermal insulating products for building applications — Determination of bending behaviour

1 Scope

This International Standard specifies the equipment and procedures for determining the bending behaviour of full-size products (Method A) and test specimens (Method B) under the action of three-point loading. It is applicable to thermal insulating products for building applications.

The test is designed to determine the bending strength of products and their deflection at a given load.

The method can be used to determine the resistance of the product to bending stresses during transport and application.

2 Normative references

The following referenced documents are indispensable for the application of this document. For dated references, only the edition cited applies. For undated references, the latest edition of the referenced document (including any amendments) applies.

ISO 5725-1, *Accuracy (trueness and precision) of measurement methods and results — Part 1: General principles and definitions*

ISO 5725-2, *Accuracy (trueness and precision) of measurement methods and results — Part 2: Basic method for the determination of repeatability and reproducibility of a standard measurement method*

ISO 29465, *Thermal insulating products for building applications — Determination of length and width*

ISO 29466, *Thermal insulating products for building applications — Determination of thickness*

ISO 29768, *Thermal insulating products for building applications — Determination of linear dimensions of test specimens*

3 Terms and definitions

For the purposes of this document, the following terms and definitions apply.

3.1

bending strength

σ_b

maximum stress calculated from the maximum force, F_m , recorded during the bending procedure

3.2

bending stress

σ_X

stress calculated from the force, F_X , at the deflection, X

3.3 deflection

X
vertical displacement of the test specimen at mid-span, at the force F_X , measured at the loading edge

4 Principle

The test method consists of applying, at a given speed, a force, F , by means of a loading edge in an axial direction to the faces of a squarely cut rectangular test specimen, which is placed on two support edges. The force is applied to the test specimen at a position midway between the supporting positions, length $L/2$ (see Figure 1).

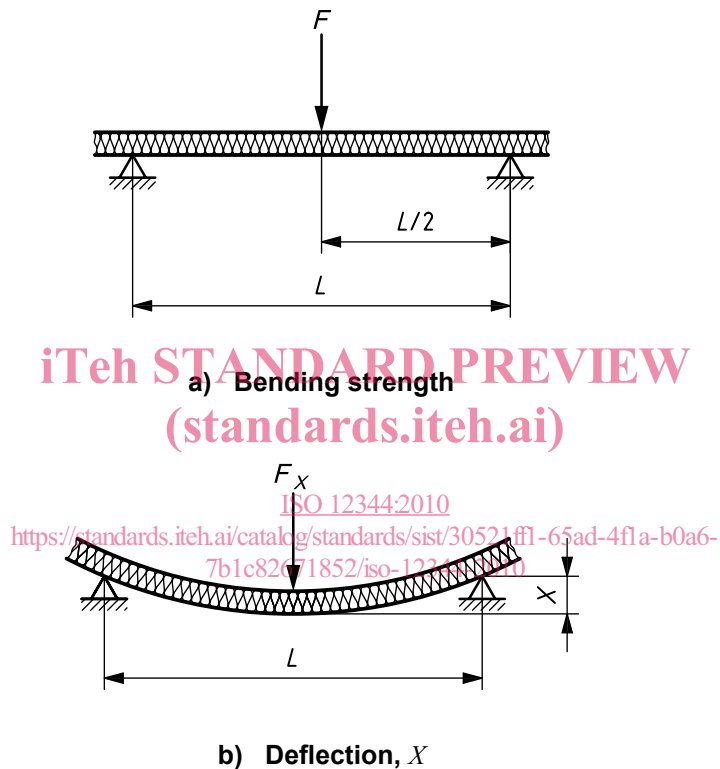

Figure 1 — Principle of test method

5 Apparatus

5.1 Test machine, suitable for the range of force and displacement involved, and with a loading edge and adjustable support edges.

The test machine shall be capable of operating at a constant rate of movement of the movable head.

The test machine includes the elements described in 5.1.1 to 5.1.3.

5.1.1 Two adjustable support edges, comprising the test specimen supports of two adjustable cylindrical support edges placed parallel to each other and in the same horizontal plane. The diameter of the supports shall be (80 ± 3) mm or (30 ± 3) mm (see Figure 2). The length of the support edges shall be at least equal to the width of the test specimens.

The span, L (see Figure 2), between the support edges shall be adjustable in the range 300 mm to 1 200 mm (Method A) or 200 mm to 500 mm (Method B).

5.1.2 Loading edge, with the same shape and dimensions as the support edges. The loading edge shall be located centrally between and parallel to the supporting edges.

5.1.3 Load distribution plates, made of steel, with a thickness of at least 1 mm for products which may be subject to crushing by the loading and support edges. The width of the distribution plates shall be (30 ± 1) mm or (80 ± 3) mm and their length shall be at least equal to the width of the test specimen.

5.2 Measuring devices for displacement and force

5.2.1 Measurement of displacement

The test machine shall be fitted with a system that allows continuous measurement of the displacement of the movable loading edge with an accuracy of $\pm 5\%$ or $\pm 0,1$ mm, whichever is the smaller. The measured displacement corresponds to the deflection, X , of the test specimen.

5.2.2 Measurement of force

A force sensor shall be fixed to the loading edge in order to measure the force, F , produced by the reaction of the test specimen upon the edges during the test. This sensor shall be such that its own deformation during the course of the measuring operation is negligible compared with that being measured or may be taken into account by calculation. In addition, it shall allow the continuous measurement of the force at all times permitting readings to $\pm 1\%$.

A device shall be used for the simultaneous recording of the force, F , and the deflection, X , to provide the force-deflection curve, required in Clause 7.

ISO 12344:2010
<https://standards.iteh.ai/catalog/standards/sist/30521ff1-65ad-4fla-b0a6-7b1c82671852/iso-12344-2010>

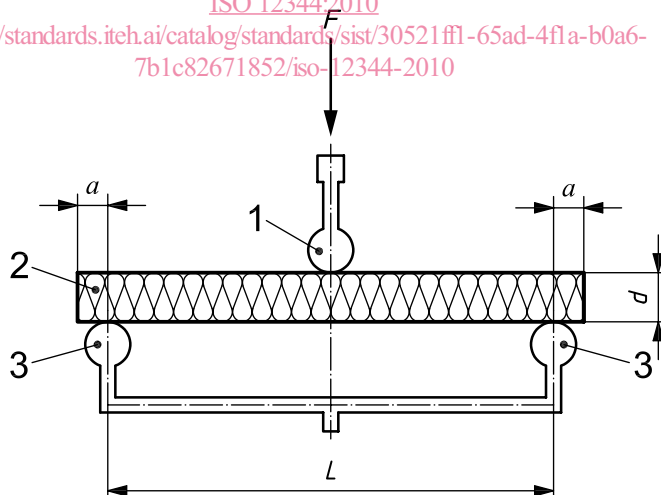

Key

- 1 loading edge
- 2 test specimen with thickness d
- 3 support edges
- a 50 mm for Method A, 25 mm for Method B
- L span between the support edges

Figure 2 — Principles of apparatus for testing of bending behaviour