

---

---

**Transport information and control  
systems — Manoeuvring Aids for Low  
Speed Operation (MALSO) —  
Performance requirements and test  
procedures**

*iTeh STANDARD PREVIEW  
(standards.iteh.ai)*  
Systèmes d'information et de commande des transports — Aides à la  
conduite pour manœuvre à vitesse réduite (MALSO) — Exigences de  
performance et modes opératoires

[ISO 17386:2010](https://standards.iteh.ai/catalog/standards/sist/2249995e-7bd2-4909-83bc-e41d9c45cf3d/iso-17386-2010)

[https://standards.iteh.ai/catalog/standards/sist/2249995e-7bd2-4909-83bc-  
e41d9c45cf3d/iso-17386-2010](https://standards.iteh.ai/catalog/standards/sist/2249995e-7bd2-4909-83bc-e41d9c45cf3d/iso-17386-2010)



**PDF disclaimer**

This PDF file may contain embedded typefaces. In accordance with Adobe's licensing policy, this file may be printed or viewed but shall not be edited unless the typefaces which are embedded are licensed to and installed on the computer performing the editing. In downloading this file, parties accept therein the responsibility of not infringing Adobe's licensing policy. The ISO Central Secretariat accepts no liability in this area.

Adobe is a trademark of Adobe Systems Incorporated.

Details of the software products used to create this PDF file can be found in the General Info relative to the file; the PDF-creation parameters were optimized for printing. Every care has been taken to ensure that the file is suitable for use by ISO member bodies. In the unlikely event that a problem relating to it is found, please inform the Central Secretariat at the address given below.

**iTeh STANDARD PREVIEW**  
**(standards.iteh.ai)**

ISO 17386:2010

<https://standards.iteh.ai/catalog/standards/sist/2249995e-7bd2-4909-83bc-e41d9c45cf3d/iso-17386-2010>



**COPYRIGHT PROTECTED DOCUMENT**

© ISO 2010

All rights reserved. Unless otherwise specified, no part of this publication may be reproduced or utilized in any form or by any means, electronic or mechanical, including photocopying and microfilm, without permission in writing from either ISO at the address below or ISO's member body in the country of the requester.

ISO copyright office  
Case postale 56 • CH-1211 Geneva 20  
Tel. + 41 22 749 01 11  
Fax + 41 22 749 09 47  
E-mail [copyright@iso.org](mailto:copyright@iso.org)  
Web [www.iso.org](http://www.iso.org)

Published in Switzerland

# Contents

Page

Foreword .....	iv
Introduction.....	v
1 Scope .....	1
2 Normative references .....	1
3 Terms and definitions .....	2
4 Classification .....	4
5 Functional and performance requirements .....	5
5.1 System activation .....	5
5.2 Driver interface and information strategy .....	5
5.3 Dynamic performance of object detection.....	7
5.4 Monitoring range coverage .....	8
5.5 Self-test capabilities and failure indication .....	14
5.6 Operation with trailers .....	15
6 Requirements and tests components .....	15
7 Operational test of obstacle detection.....	15
7.1 Test object.....	15
7.2 General ambient conditions .....	16
7.3 Test procedure.....	16
Annex A (informative) Test methods .....	18
Bibliography.....	21

## Foreword

ISO (the International Organization for Standardization) is a worldwide federation of national standards bodies (ISO member bodies). The work of preparing International Standards is normally carried out through ISO technical committees. Each member body interested in a subject for which a technical committee has been established has the right to be represented on that committee. International organizations, governmental and non-governmental, in liaison with ISO, also take part in the work. ISO collaborates closely with the International Electrotechnical Commission (IEC) on all matters of electrotechnical standardization.

International Standards are drafted in accordance with the rules given in the ISO/IEC Directives, Part 2.

The main task of technical committees is to prepare International Standards. Draft International Standards adopted by the technical committees are circulated to the member bodies for voting. Publication as an International Standard requires approval by at least 75 % of the member bodies casting a vote.

Attention is drawn to the possibility that some of the elements of this document may be the subject of patent rights. ISO shall not be held responsible for identifying any or all such patent rights.

ISO 17386 was prepared by Technical Committee ISO/TC 204, *Intelligent transport systems*.

This second edition cancels and replaces the first edition (ISO 17386:2004), which has been technically revised.

ITIH STANDARD PREVIEW  
(standards.iteh.ai)

ISO 17386:2010

<https://standards.iteh.ai/catalog/standards/sist/2249995e-7bd2-4909-83bc-e41d9c45cf3d/iso-17386-2010>

## Introduction

Today's aerodynamically-shaped vehicles often result in restricted rear and front visibility. Manoeuvring aids for low-speed operation (MALSO) enhance security and driver convenience during parking or manoeuvring situations at very low speed, e.g. in narrow passages. Drivers can avoid collisions with obstacles that cannot be seen but can be detected by the system and they can make more effective use of limited parking space.

MALSO systems are detection devices with non-contact sensors which assist the driver during low speed manoeuvring. MALSO systems indicate to the driver the presence of front, rear or corner objects when squeezing into small parking spaces or manoeuvring through narrow passages. They are regarded as an aid to drivers for use at speeds of up to 0,5 m/s, and they do not relieve drivers of their responsibility when driving the vehicle.

## iTeh STANDARD PREVIEW (standards.iteh.ai)

[ISO 17386:2010](https://standards.iteh.ai/catalog/standards/sist/2249995e-7bd2-4909-83bc-e41d9c45cf3d/iso-17386-2010)

<https://standards.iteh.ai/catalog/standards/sist/2249995e-7bd2-4909-83bc-e41d9c45cf3d/iso-17386-2010>

**iTeh STANDARD PREVIEW**  
**(standards.iteh.ai)**

ISO 17386:2010

<https://standards.iteh.ai/catalog/standards/sist/2249995e-7bd2-4909-83bc-e41d9c45cf3d/iso-17386-2010>

# Transport information and control systems — Manoeuvring Aids for Low Speed Operation (MALSO) — Performance requirements and test procedures

## 1 Scope

This International Standard addresses light-duty vehicles, e.g. passenger cars, pick-up trucks, light vans and sport utility vehicles (motorcycles excluded) equipped with MALSO systems. It specifies minimum functionality requirements which the driver can generally expect of the device, i.e. detection of and information on the presence of relevant obstacles within a defined (short) detection range. It defines minimum requirements for failure indication as well as performance test procedures; it includes rules for the general information strategy but does not restrict the kind of information or display system.

MALSO systems use object-detection devices (sensors) for ranging in order to provide the driver with information based on the distance to obstacles. The sensing technology is not addressed; however, technology affects the performance-test procedures set up in this International Standard (see Clause 7). The current test objects are defined based on systems using ultrasonic sensors, which reflect the most commonly used technology at the time of publishing this International Standard. For other sensing technologies possibly coming up in the future, these test objects shall be checked and changed if required.

Visibility-enhancement systems like video-camera aids without distance ranging and warning are not covered by this International Standard.

Reversing aids and obstacle-detection devices on heavy commercial vehicles are not addressed by this International Standard; requirements for those systems are defined in ISO/TR 12155.

## 2 Normative references

The following referenced documents are indispensable for the application of this document. For dated references, only the edition cited applies. For undated references, the latest edition of the referenced document (including any amendments) applies.

ISO 2575, *Road vehicles — Symbols for controls, indicators and tell-tales*

ISO 15006, *Road vehicles — Ergonomic aspects of transport information and control systems — Specifications and compliance procedures for in-vehicle auditory presentation*

ISO 15008, *Road vehicles — Ergonomic aspects of transport information and control systems — Specifications and test procedures for in-vehicle visual presentation*

ISO 16750 (all parts), *Road vehicles — Environmental conditions and testing for electrical and electronic equipment*

### 3 Terms and definitions

For the purpose of this document, the following terms and definitions apply.

#### 3.1

##### **audible information and warning**

acoustical signal that is used to present information about relevant obstacles, to the driver

EXAMPLE Pulses, speech.

NOTE Acoustical pulses can be coded mainly by carrier frequency, repetition rate and position of sound generator.

See Figure 1.

#### 3.2

##### **evaluation for information and advice**

information about detected obstacles that, when the system is activated, will be evaluated to warn and advise the driver in order to help with the current low speed manoeuvre

See Figure 1.

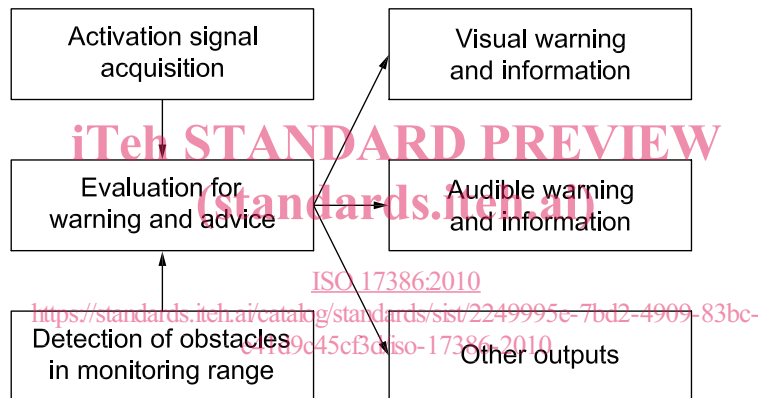

Figure 1 — Block diagram of the potential sub-functions of a manoeuvring aid for low-speed operation

#### 3.3

##### **manoeuvring aid for low-speed operation**

system that, at low speeds (< 0,5 m/s), is capable of informing the driver of the presence of stationary obstacles in particular areas in close proximity to the subject vehicle, mainly during parking and manoeuvring in narrow passages

#### 3.4

##### **monitoring range**

###### **m.r.**

specific three-dimensional space around the vehicle, which is divided into rear and front corner m.r., front, rear-1 and rear-2 m.r.

NOTE The covered monitoring ranges depend on the intended use of the system (see Clause 4).

See Figure 2.

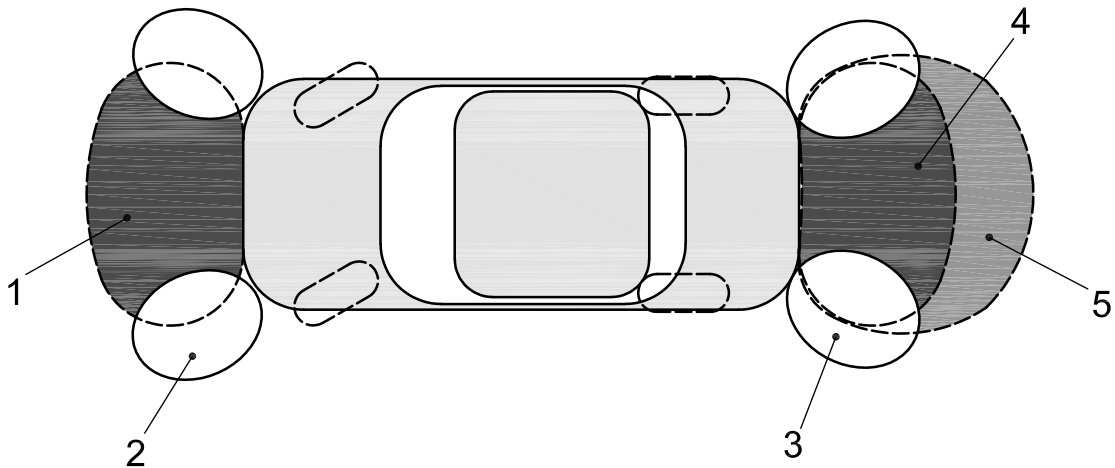

**Key**

- 1 front
- 2 front corner
- 3 rear corner
- 4 rear-1
- 5 rear-2

**Figure 2 — Monitoring ranges (plan view)**

iTeh STANDARD PREVIEW  
(standards.iteh.ai)

**3.5****reversing detection system**

system that gives an indication to the driver, when the reverse gear is selected, whether there are objects in the monitoring range

**3.6****sensor**

component that detects objects in the monitoring range

NOTE There are a variety of sensor principles listed below which could be used.

The most common principle is the flight time measurement (e.g. radar, lidar, sonar). Active sensor elements create a pulsed or continuously modulated field of microwaves, (infrared) light, or ultrasonic sound. The reflected energy due to an object in the detection area is received, and the distance to the object is measured. The lateral position of the object is estimated based on the beam or field directional characteristics, or based on the timing relationships between sensors with overlapping coverage areas.

Alternative principles include distance measurement by triangulation principle and passive sensor systems using image processing.

**3.7****system activation**

action of transitioning the system operation from a quiescent mode to an active one in which the system is monitoring the monitoring ranges, evaluating the objects detected and generating appropriate feedback to assist the driver

**3.8****test object**

object with a specific material, geometry and surface for testing the monitoring range

NOTE This test object should give comparable results for the relevant sensor types.

**3.9 visual information and warning**

optical signal which is used to present information about relevant obstacles to the driver

EXAMPLE Telltale, display.

NOTE Visual information can be coded, e.g. by colour, repetition rate, symbols or text. The driver can be warned by continuous or pulsating signalling of possibly coloured telltales. Information can be graphical or alphanumeric.

**3.10 warning levels**

progressive critical levels of audible/visual/tactile/kinaesthetic information or feedback to the driver regarding the hazard environment

**4 Classification**

The MALSO system classification reflects the diversity of driving behaviour and market demand in different regions of the world. For example, in certain countries, drivers manoeuvre within a very tight area and have come to rely on warnings given at very short range. In other regions, drivers expect warnings to be given at a relatively longer range. A manufacturer may select the most suitable system parameters based on the driving style and expectations of the target driver population.

The manoeuvring aids for low-speed operation are classified according to their capability of covering the different monitoring ranges. Each monitoring range corresponds to a particular part of the vehicle boundary to prevent colliding with an obstacle. See Figure 2. The class of the system is indicated by an abbreviation corresponding to the monitoring ranges covered.

TECHNICAL STANDARD PREVIEW  
(standards.iteh.ai)

**Table 1 — Classification of manoeuvring aids for low-speed operation — Abbreviations of monitoring ranges**

Monitoring range	Abbreviation	Detection distance m	Maximum driving speed m/s
Rear-1	R1	0,6	0,3
Rear-2	R2	1,0	0,5
Rear corner driver side	Rcd	0,5	0,3
Rear corner passenger side	Rcp	0,5	0,3
Front	F	0,6	0,3
Front corner driver side	Fcd	0,5	0,3
Front corner passenger side	Fcp	0,5	0,3

Any combination of monitoring ranges may be used, if it is beneficial for the intended use of the system.

The corner type systems have monitoring ranges restricted to particular corners of the vehicle and are mainly intended to assist the driver while driving through narrow passages.

For convenience and most efficient use of the manoeuvring aid the driver shall be informed about the type of system the vehicle is equipped with, according to the classification above.

## 5 Functional and performance requirements

### 5.1 System activation

#### 5.1.1 Systems with manual activation

The system is turned ON and OFF by the driver with a switch or push-button. After activation, the system may indicate readiness for service acoustically or visually. This indication shall be clearly distinguishable from distance information about obstacles.

#### 5.1.2 Systems with automatic activation

The system is activated/deactivated automatically according to the driving situation. The possible monitoring ranges (see Clause 4) may be activated separately in order to avoid nuisance signals. After automatic activation, readiness for service may be indicated to the driver. There may be an on/off switch or push-button to override automatic (de)activation.

Activation criteria are **Reverse gear selected** on the one hand and **speed below a specified limit  $v_{on}$**  on the other hand. Deactivation criteria may be **Gear other than reverse is selected, speed beyond a specified limit  $v_{off}$  or distance moved since last system activation greater than  $x_{off}$** . The speed limits,  $v_{on}$  and  $v_{off}$ , and the distance limit,  $x_{off}$ , may be defined appropriately to the sensor technology and the intended use of the system; however,  $v_{on}$  and  $v_{off}$  shall be  $\geq 0,5$  m/s or  $\geq 0,3$  m/s, depending on the monitoring range under consideration (see Table 1), since these are the maximum velocities supported by the system.

Table 2 shows how the different existing monitoring ranges should be activated.

Table 2 — System activation/deactivation criteria

Monitoring range	Reverse gear selected	Gear other than reverse is selected	
		$v < v_{on}$	$v \geq v_{off}$ OR $x > x_{off}$
Front	o	+	–
Front corners	o	+	–
Rear	+	o	–
Rear corners	+	o	–
“o” indicates optional. “+” indicates active. “–” indicates inactive.			

On vehicles with automatic transmission the MALSO system may be deactivated if the P (parking) gear position is selected. It is also possible to deactivate the system while the parking brake is engaged.

### 5.2 Driver interface and information strategy

#### 5.2.1 General information presentation

For the driver interface, at least the audible information channel shall be used. Visual information and warning may be used as a supplement. A standardized information strategy will be the basis for the development of both types of information components, as this makes the use in different vehicles easier and safer. The most relevant information for the driver is the distance, i.e. the clearance, between the vehicle boundary and an obstacle. The location of the obstacle relative to the vehicle may be indicated as additional information.

Failures shall be indicated to the driver as well.