



Standard Specification for Strapping, Flat Steel and Seals¹

This standard is issued under the fixed designation D 3953; the number immediately following the designation indicates the year of original adoption or, in the case of revision, the year of last revision. A number in parentheses indicates the year of last reappraisal. A superscript epsilon (ϵ) indicates an editorial change since the last revision or reappraisal.

This standard has been approved for use by agencies of the Department of Defense.

1. Scope

1.1 This specification covers flat steel strapping and seals intended for use in closing, reinforcing, bundling articles for shipment, unitizing, palletizing, and bracing for carloading and truckloading.

1.2 This specification includes strapping and seals made from carbon steel and applies only to the types and sizes as cataloged by strapping suppliers to be a standard, commercially available product. It does not include “specialty”-type strapping as developed for special applications or strapping produced from alloy metals.

1.3 The values stated in inch-pound units are to be regarded as standard.

1.4 The following safety hazards caveat applies only to the test method portion, Sections 11, 12, and 13, of this specification: *This standard does not purport to address all of the safety concerns, if any, associated with its use. It is the responsibility of the user of this standard to establish appropriate safety and health practices and determine the applicability of regulatory limitations prior to use.*

2. Referenced Documents

2.1 ASTM Standards:

A 90/A90M Test Method for Weight (Mass) of Coating on Iron or Steel Articles with Zinc or Zinc-Alloy Coatings²

A 109 Specification for Steel, Strip, Carbon, Cold-Rolled³

A 239 Test Method for Locating the Thinnest Spot in a Zinc (Galvanized) Coating on Iron or Steel Articles by the Preece Test (Copper Sulfate Dip)²

B 504 Test Method for Measurement of Thickness of Metallic Coatings by the Coulometric Method⁴

D 996 Terminology of Packaging and Distribution Environments⁵

D 3951 Practice for Commercial Packaging⁵

D 4332 Practice for Conditioning Containers, Packages, or Packaging Components for Testing⁵

¹ This specification is under the jurisdiction of ASTM Committee D-10 on Packaging and is the direct responsibility of Subcommittee D10.25 on Palletizing and Unitizing of Loads.

Current edition approved April 10, 1997. Published February 1998. Originally published as D 3953 – 83. Last previous edition D 3953 – 91

² *Annual Book of ASTM Standards*, Vol 01.06.

³ *Annual Book of ASTM Standards*, Vol 01.03.

⁴ *Annual Book of ASTM Standards*, Vol 02.05.

⁵ *Annual Book of ASTM Standards*, Vol 15.09.

D 4675 Guide for Selection and Use of Flat Strapping Materials⁵

E 177 Practice for Use of the Terms Precision and Bias in ASTM Test Methods⁶

E 691 Practice for Conducting an Interlaboratory Study to Determine the Precision of a Test Method⁶

2.2 Military Standard:

MIL-STD-105 Sampling Procedures and Tables for Inspection by Attributes⁷

2.3 AAR General Rules 15

AAR Rule Governing the Loading of Commodities on Open Top Cars⁸

3. Terminology

3.1 General definitions for packaging and distribution environments are found in Terminology D 996.

4. Strapping Classifications

4.1 Strapping shall be of the following types, finish and sizes:

Type 1, Flat Strapping: Power Machine and Hand Application:

Regular-duty

Heavy-duty

Heavy-duty, high elongation

Type 2: Nail-On

4.1.1 Strapping Finish, Lubricated or Dry (see 8.3):

4.1.1.1 Finish A—Organic (Pigmented or Unpigmented Paint)

4.1.1.2 Finish B—Galvanized (Hot Dipped or Electro-Deposit Galvanized) (see 8.10):

Grade 1—Heavy Coating

Grade 2—Moderate Coating

Grade 3—Commercial Coating

4.1.1.3 Finish C—Organic Painted Metallic Filled (Aluminum or Zinc)

4.1.1.4 Finish D—Uncoated

4.1.2 Strapping Sizes— Strapping shall have the widths and

⁶ *Annual Book of ASTM Standards*, 14.02.

⁷ Available from Standardization Documents Order Desk, Bldg. 4 Section D, 700 Robbins Ave., Philadelphia, PA 19111-5094, Attn: NPODS.

⁸ AAR Rule Governing the Loading of Commodities on Open Top Cars, Section No. 1 General Rules—Rule 15, available from the Association of American Railroads, Mechanical Division 50 F St., NW, Washington, DC 20001.

thicknesses in accordance with sizes shown in Table 1 and Table 2.

5. Seal Classifications

5.1 Seals shall be of the following classes, finishes, types, and styles:

5.1.1 Seal Classes:

R—Regular duty

H—Heavy duty

5.1.2 Seal Finishes:

Finish A—Organic (painted)

Finish B—Galvanized (hot dipped or electro-deposit galvanized)

Grade 1—Heavy coating

Grade 2—Moderate coating

Grade 3—Manufacturer’s standard commercial practice

Finish C—Uncoated

5.1.3 Seal Styles:

I—Snap-on or open

II—Thread-on or closed

III—Push-type or overlap

IV—Magazine-feed

V—Intersectional or cross-tie

5.2 Seal Sizes—Seals shall have widths in accordance with strapping width shown in Table 1 and Table 2.

6. Ordering Information

6.1 The inquiry and order shall indicate the following:

6.1.1 Strapping type, duty, finish, grade, lubrication (when applicable), dimension required, and quantity of each size (see Section 4).

6.1.2 Coil of strapping dimensions, weight and feet per pound, oscillated, ribbon wound, or cut-to-length (see Section 9, Table 3 and Table 4, and Fig. 1 and Fig. 2).

6.1.3 Seals (see Section 5) class, finish, grade (when applicable), type, style, and quantity by width (or nomenclature).

6.1.4 Make or model of strapping equipment that the strapping and seals must work in, if applicable.

6.1.5 Title, designation, and date of this specification.

6.1.6 For Department of Defense, indicate selection of preservation, packing, marking, and palletization, if applicable (see Section 16).

6.2 Sizes or physical properties, or both, other than those covered by this specification shall be as specified in the contract or order.

7. Materials and Manufacture

7.1 Materials shall be cold-rolled carbon steel of the quality

normally used for this purpose in commercial practice, and the physical mechanical property requirements, as determined by tests, shall be within the allowable limits.

7.1.1 *Type 1 Regular-Duty Strapping*—Regular-duty strapping in Table 1 shall be low-carbon cold-rolled steel (see 6.1.1).

7.1.2 *Type 1 Heavy-Duty Strapping*—Heavy-duty strapping in Table 2 shall be cold-rolled, high-carbon, or medium carbon high-manganese steel which has been fully heat-treated; for example, austenitized and quenched.

7.1.3 *Type 1 Heavy-Duty, High-Elongation Strapping*—Heavy-duty, high-elongation strapping in Table 2 shall be high-carbon steel which has been fully heat-treated; for example, austenitized and quenched to provide the elongations in 8.1.2.

7.1.4 *Type 2 Nail-On Strapping*—Unless otherwise specified, Type 2 nail-on strapping shall be strapping made from Type 1 regular-duty or Type 1 heavy-duty strapping, available in sizes 5/8 in. (15.87 mm) in width or greater with punched nail holes. Hole diameters and hole spacing can vary depending upon strap size and duty, which shall be in accordance with manufacturer’s standard practice. However, nail holes shall be spaced at intervals no more than 3 in. (76 mm) apart.

7.1.5 *Seals for Type 1 Strapping*—Unless otherwise specified, seals for Type 1 strapping shall be made of steel in accordance with the manufacturer’s commercial practice.

8. Physical and Mechanical Properties

8.1 *Breaking Strength and Elongation, Type 1 Regular-Duty and Heavy-Duty Strapping:*

8.1.1 *Breaking Strength*—The breaking strength of the strapping shall be as shown in Table 1 and Table 2 when tested as specified in 13.3.

8.1.2 *Elongation*—The elongation in 6 in. (152 mm) for Type 1 strapping, when tested as specified in 13.4, shall be as follows:

Regular-duty (see 7.1.1)	0.5 to 4.0 %
Heavy-duty (see 7.1.2)	
Thickness less than 0.031 in. (0.79 mm)	5.0 to 12 %
Thickness 0.031 in. (0.79 mm) and greater	6.5 to 12 %
Heavy-duty high elongation (see 7.1.3)	
Thickness 0.035 in. (0.889 mm) and greater	9.0 to 16 %

8.2 *Tolerances, Type 1 Strapping, Widths*—The widths of the strapping shall not vary from that shown in Table 1 and Table 2 by more than ± 0.005 in. (0.13 mm) for all cold-rolled strapping.

8.2.1 *Type 1 Strapping, Thickness*—The thickness of strapping sizes listed in Table 1 and Table 2 shall not vary from

TABLE 1 Type 1 Regular-Duty Strapping Widths, Thickness, and Breaking Strengths

Width, in. (mm)	Thickness, in. (mm)							
	0.010 (0.25)	0.012 (0.30)	0.015 (0.38)	0.018 (0.46)	0.020 (0.51)	0.023 (0.58)	0.028 (0.71)	0.035 (0.89)
Breaking Strength, min. lbf (N)								
3/8 (9.52)	300 (1335)	360 (1600)	450 (2000)	540 (2400)	600 (2670)	690 (3070)
1/2 (12.70)	400 (1780)	480 (2135)	600 (2670)	720 (3200)	800 (3560)	920 (4090)
5/8 (15.87)	500 (2225)	600 (2670)	750 (3335)	900 (4000)	1000 (4450)	1150 (5115)
3/4 (19.05)	900 (4000)	...	1200 (5340)	1380 (6140)	1680 (7470)	2100 (9340)

TABLE 2 Type 1 Heavy-Duty, Heavy-Duty/High Elongation Strapping Widths, Thickness, and Breaking Strengths

Width, in. (mm)	Thickness, in. (mm)										
	0.020 (0.51)	0.022 (0.56)	0.023 (0.58)	0.025 (0.64)	0.028 (0.71)	0.029 (0.75)	0.031 (0.79)	0.035 (0.89)	0.044 (1.12)	0.050 (1.27)	0.057 (1.45)
Breaking Strength, min, lbf (N)											
1/2 (12.70)	1 280 (5 690)	...	1 470 (6 540)	1 950 (8 675)
5/8 (15.87)	1 600 (7 120)	...	1 840 (8 185)
3/4 (19.05)	2 000 (8 896)	2 280 (10 140)	2 280 (10 140)	2 280 (10 140)	2 280 (10 140)	2 850 (12 675)	2 850 (12 675)	2 850 (12 675)	4 050 (18 015)	4 050 (18 015)	...
1 (25.4)	3 700 (16 455)	3 700 (16 455)
1 1/4 (31.75)	3 200 (14 240)	3 680 (16 370)	...	4 750 (21 130)	4 750 (21 130)	4 750 ^A (21 130)	6 750 (30 025)	6 750 (30 025)	7 700 (34 250)
2 (50.80)	10 600 (47 150)	10 600 (47 150)	...

^A Heavy-duty, or heavy-duty/high elongation.

TABLE 3 Number of Feet Per Pound (Metres per Kilogram) of Type 1 Strapping^A

NOTE 1—Number of feet per pound (metres per kilogram) is based on nominal dimensions and will vary slightly with the width and thickness of the strapping within the tolerances as described in 8.2.

Width, in. (mm)	Thickness, in. (mm)														
	0.010 (0.25)	0.012 (0.311)	0.015 (0.38)	0.018 (0.46)	0.020 (0.51)	0.022 (0.56)	0.023 (0.58)	0.025 (0.64)	0.028 (0.71)	0.029 (0.75)	0.031 (0.79)	0.035 (0.89)	0.044 (1.12)	0.050 (1.27)	0.057 (1.45)
Length per Unit Mass, ft/lb (m/kg), approximate															
3/8 (9.52)	78.5 (52.7)	65.4 (43.9)	52.4 (35.2)	43.6 (29.3)	39.3 (26.4)
1/2 (12.70)	58.9 (39.6)	49.1 (33.0)	39.3 (26.4)	32.7 (22.0)	29.4 (19.7)	19.0 (12.7)
5/8 (15.87)	47.1 (31.6)	39.3 (26.4)	31.4 (21.1)	26.2 (17.6)	23.6 (15.8)
3/4 (19.05)	26.2 (17.6)	19.6 (13.1)	17.8 (11.9)	17.1 (11.5)	15.7 (10.5)	14.0 (9.4)	13.5 (8.95)	12.7 (8.5)	11.2 (7.5)
1 (25.4)	10.1 (6.7)	9.5 (6.3)
1 1/4 (31.75)	11.8 (7.9)	9.4 (6.3)	...	8.1 (5.5)	7.6 (5.1)	6.6 (4.4)	5.3 (3.5)	4.7 (3.1)	4.1 (2.8)	...
2 (50.80)	3.3 (2.2)	2.9 (1.9)

^A Commercial tolerances apply.

nominal thickness by more than the following:
Cold-rolled strapping 0.031 in. (0.79 mm) or less in thickness + 0.002 in. (0.05 mm), - 0.001 (0.03 mm).

Cold-rolled strapping greater than 0.031 in. (0.79 mm) in thickness up to 0.057 in. (1.45 mm) ±0.002 in. (0.05 mm).

8.3 *Lubrication*— Unless otherwise specified, Type 1 strapping shall have a coating of wax or wax-like lubricant applied to the surfaces that will render the strapping suitable for application with tension tools of the feed wheel (friction) type (see 4.1.2 and 6.1.4). The lubrication of the strapping is intended to facilitate the use of strapping tools in which the two bands of the strapping are held in contact with each other under pressure by frictional grips, and sliding of the faces of the strapping is necessary during the tensioning operation. Test in accordance with 13.9.

8.4 *Type 1 Strapping, Coils*—Each coil shall consist of one continuous piece of strapping. Coils with lengths of strapping welded together shall be considered as one-piece coil. Type 1 strapping shall have no more than two welded joints in any coil.

8.4.1 *Dimensional Requirements at the Weld*—The thickness at the weld shall be no more than one and one half the thickness of the strap. The width of strapping at the weld shall

be subject to the same dimensional requirements as the remainder of the strapping. Metal splattering or extruded points causing increased thickness are not permissible. Only machine welds shall be acceptable.

8.4.2 *Weld Efficiency*— Strength of manufacturer's process welded joints in coils of strapping shall have a joint efficiency of not less than 75 % based on the breaking strength shown in Table 1 and Table 2 when tested as specified in 13.6.

8.5 *Identification Marking*—Each coil of Type 1 heavy-duty, 1 1/4-in. (31.75-mm) by 0.029 in. (0.75 mm) in thickness and greater and 2-in. wide (50.8-mm) strapping shall be marked in accordance with the Association of American Railroads General Rule 15. The marking shall consist of the letters "AAR," the manufacturer's or distributor's name, or abbreviated name, or registered trademark, or symbol, or AAR code consisting of two digits. Marking shall be spaced not more than 5 ft (1.52 m) apart.

8.6 *Type 2 Strapping*:

8.6.1 *Breaking Strength*—The breaking strength for Type 2 strapping shall be the same as shown in Table 1 or 2 for the applicable strapping size and type, but shall be based on the cross-sectional metal area of the strapping taken across the hole. Breaking strength will be reduced proportionally in

TABLE 4 Size of Coils and Package

Type Coils	Size of Strapping, in. (mm)	Inside Diameter, in (mm) (Commercial Tolerance)	Outside Diameter, max, in. (mm)	Coils Per Package, max
Oscillated	3/8 by 0.010 (9.52 by 0.25) through 3/4 by 0.035 (19.05 by 0.89)	16 (406)	23 1/2 (597)	1
Ribbon	3/4 by 0.022 (19.05 by 0.56) through 3/4 by 0.035 (19.05 by 0.89)	16 (406)	27 (686)	2
	1 by 0.029 (25.4 by 0.75) through 1 by 0.031 (25.4 by 0.79)	16 (406)	27 (686)	1
	1 1/4 by 0.020 (31.75 by 0.51) through 1 1/4 by 0.057 (31.75 by 1.45)	16 (406)	27 (686)	1
	2 by 0.044 (50.80 by 1.12) through 2 by 0.050 (50.80 by 1.27)	16 (406)	25 7/8 (657)	1

accordance with nail hole diameter.

8.6.2 *Tolerances*—The tolerances on width and thickness for Type 2 strapping shall be the same as for Type 1 strapping (see 8.2).

8.7 *Seals, Type 1 Strapping*—Seals intended for Type 1 strapping shall be made of steel to manufacturer’s commercial practice. Seal lengths shall be adequate for a single-notch joint (one pair of cut notches), a double-notch joint (two pairs of cut notches), a double-crimp joint (two pairs of crimps), a triple-crimp joint (three pairs of crimps), or a quadruple-crimp joint (four pairs of crimps). Unless otherwise specified, seals shall be suitable in size or design to satisfy the requirements of 8.9.2 and 8.9.3.

8.7.1 *Seal Width*—Seal width shall be adequate to allow the seal to slip on the applicable strapping and shall be compatible with the sealing tool used to provide the required joint strength.

8.7.2 *Seals, Regular- and Heavy-Duty*, Seals shall be in thickness and hardness suitable for use with regular- or heavy-duty strapping. Regular-duty seals shall be used with regular-duty strapping and heavy-duty seals with heavy-duty strapping.

8.8 *Application of Seals:*

8.8.1 *Style I*—Style I seals shall have one or both sides open so that the seal shall slip in the overlapping bands of strapping either during or after tensioning the strapping.

8.8.2 *Style II*—Style II seals shall have sides partially closed at the bottom of the seal so that this seal shall be prethreaded with the overlapping bands of strapping before the tensioning tool is applied.

8.8.3 *Style III*—Style III seals shall have the sides completely closed by overlapping at the bottom of the seal so that

prethreading with the overlapping bands of strapping and bending of the bottom strap under the seal can be accomplished. The seal shall permit the tensioning tool to tension the strapping as the tool butts against the seal.

8.8.4 *Style IV*—Style IV seals shall have sides opened to allow nesting and stacking of the seals for hand or power tools with magazine feed. Seals shall fit and form joints with the seal manufacturer’s tool model as specified (see 6.1.4). Means provided on Style IV seals to facilitate stacking are acceptable.

NOTE 1—Style IV seals are commonly designed for use with the seal manufacturer’s tool and are not adaptable for other manufacturer’s tools.

8.8.5 *Style V*—Style V seals shall have one or both sides open so that the seal shall slip on the crossing bands of strapping either during or after tensioning of the straps.

8.9 *Sealed Joints:*

8.9.1 *Fastening Flat Steel Strapping*—The various methods of fastening flat steel strapping in use commercially are notched seal joints, crimped seal joints, and sealless joints made by die cutting or spot welding the overlapping ends of the strapping. These methods are acceptable provided that the joint made meets the efficiency requirements, as follows:

8.9.2 *Notch Joints*, Notch-type seal joints made with hand tools, power hand tools, or power strapping machines recommended by the supplier, shall be made on applicable strapping, without cracking and tearing of the seal metal. Notched seal joints are usually intended for use with lubricated (waxed) strapping. Notched seal joints when used with Type 1 regular-duty strapping, or Type 1 heavy-duty strapping must have a minimum joint strength of 75 % for double-notch joints and 45 % for single-notch joints. Joint strength is based on the minimum breaking strength of the applicable strapping size as shown in Table 1 and Table 2 when tested as specified in 13.5. Examples of notch-type seal joints are shown in Fig. 3.

8.9.3 *Crimp Joints*—Crimp-type seal joints, made with hand tools or power hand tools, shall be made on applicable strapping without cracking and tearing of the seal metal. Crimped seal joints are usually intended for use with dry Type 1 heavy-duty strapping, primarily where severe impact or heavy stresses on the strap and joint may be encountered. Crimp joints may also be used with lubricated (waxed) strapping, provided the loss in friction is compensated for by adding sufficient additional seals and crimps, or by using “Grit”-type friction seals. Crimp seal joints when used with Type 1 heavy-duty (high-tension) strapping in sizes 3/4 by 0.031 in. (19.05 by 0.79 mm) or greater must have a minimum joint efficiency of 75 % based on the minimum breaking strength of the applicable strapping size as shown in Table 2 when tested as specified in 13.5. Three or more crimps will be required to attain or exceed the 75 % joint efficiency as determined by seal, strap, and strap finish combination. Increased joint strength can be obtained by the addition of more seals and crimps. Examples of crimp-type seal joints are shown in Fig. 1.

8.9.4 Seal joint efficiency tests should be performed periodically on both notch- and crimp-type joints to ensure that the seal and sealer combination provides the desired joint strength.

8.9.5 Die-cut sealless joints shall have a minimum joint efficiency of 75 % based on the minimum breaking strength of the applicable strapping size as shown in Table 1 or Table 2,

TYPICAL
RECOMMENDED
CRIMP TYPE JOINTS

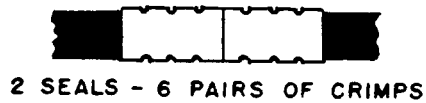

TYPICAL
RECOMMENDED
NOTCH TYPE JOINTS

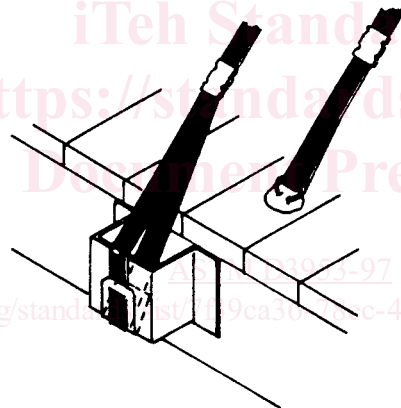

LOOP TYPE SECUREMENT, AS ILLUSTRATED,
REQUIRES ONLY ONE SEAL PROPERLY SEALED,
TO PROVIDE ACCEPTABLE JOINT EFFICIENCY.

FIG. 1 Recommended Seal Joints

when tested as specified in 13.5. For exceptions, see AAR General Rules 15.

8.9.6 Spot-welded sealless joints shall have a minimum joint efficiency of 75 % based on the breaking strength of the applicable strapping size as shown in Table 1 or Table 2, when tested as specified in 13.5. Table 4

8.10 *Galvanized Strapping*—Finish B galvanized strapping shall have the following minimum coating weights or thicknesses, or both, when tested as specified in 13.7 (see 10.2.3 and Table 5).

Grade 1—0.30 oz/ft²(92 g/m²) of surface or 0.0005 in. (0.013 mm) thick.

Grade 2—0.18 oz/ft²(55 g/m²) of surface or 0.0003 in. (0.008 mm) thick.

Grade 3—In accordance with manufacturer's commercial practice but no less than 0.06 oz/ft²(18 g/m²) of surface or 0.0001 in. (0.003 mm) thick.

8.10.1 Edges of Grades 1, 2, and 3 shall not show signs of copper sulfate when tested in accordance with 13.10.

8.11 *Ductility of Strapping Coating*—Finish A, painted finish, Finish B, galvanized, Finish C, metallic-filled strapping shall not crack or flake on the outside of the bent portion, except that cracks on the strapping shall be disregarded within a distance from the edge of the strapping equal to one fourth of the width when tested as specified in 13.8.

8.12 *Base Metal Ductility (Bend Test)*—Strapping of various thicknesses shall withstand the minimum number of bends in one area as shown in Table 6. The test procedure is described

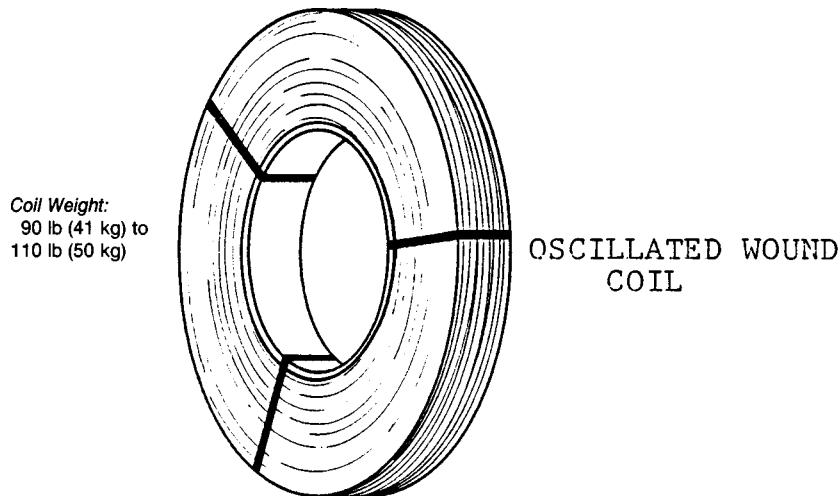

FIG. 2 Oscillated Wound Coil

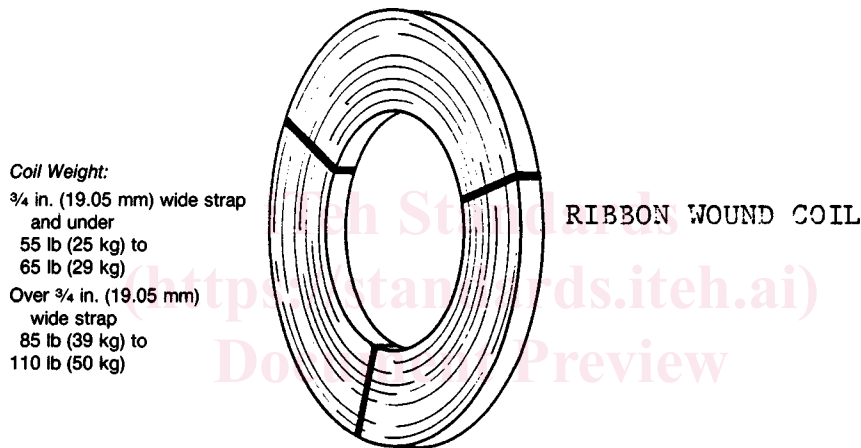

FIG. 3 Ribbon-wound Coil

TABLE 5 Mass Loss of Zinc Coating

Strapping Width		Minimum Mass Loss, mg/6-in. (152-mm) Specimen		
in.	(mm)	Grade 1	Grade 2	Grade 3
3/8	(9.52)	263	158	53
1/2	(12.70)	350	210	70
5/8	(15.87)	438	262	87
3/4	(19.05)	525	315	105
1	(25.40)	700	420	140
1 1/4	(31.75)	875	525	175
2	(50.8)	1400	840	280

TABLE 6 Metal Bend Test Requirements for Strapping

Thickness		Number of Bends
in.	(mm)	
0.010	(0.25)	15
0.012	(0.31)	12
0.015	(0.38)	12
0.018	(0.46)	10
0.020	(0.51)	8
0.022	(0.56)	6
0.023	(0.58)	6
0.025	(0.64)	6
0.028	(0.71)	5
0.029	(0.75)	5
0.031	(0.79)	5
0.035	(0.89)	5
0.044	(1.12)	3
0.050	(1.27)	3
0.057	(1.45)	3

under 13.2, and shall be conducted on the final finished product.

8.13 Straightness—Type 1 Strapping:

8.13.1 Camber—Camber in the strapping shall not be more than 1/2 in. (12 mm) in any 8-ft (2.4-m) length, when measured in accordance with Specification A 109, Table 10.

8.13.2 Coil Set (Bundle Curve)—Strap ends shall not rise from horizontal flat plain more than 2 in. (50.8 mm) in any 8-ft (2.4-m) long section of strap.

8.13.3 Spiral Twist (Cork Screw Effect)—Twist must not exceed 20° in any 8 ft (2.4 m) long section of strap, when laid on horizontal flat surface.

9. Coil Configuration and Permissible Weight Variations

9.1 Type 1 Coils—Type 1 and Type 2 strapping shall be oscillated (mill)-wound coils weighing not less than 90 lb (41 kg) or more than 110 lb (50 kg) (see Fig. 2) and ribbon-wound coils weighing not less than 55 lb (25 kg) nor more than 110 lb (50 kg) when put up as specified in Table 4 (also see Fig. 3). Oscillated- and ribbon-wound coils of strapping are used in