**Safety of machinery — Evaluation of the
emission of airborne hazardous
substances —**

Part 5:

**Test bench method for the measurement
of the separation efficiency by mass of
air cleaning systems with unducted outlet**

iTeh STANDARD PREVIEW
(standards.iteh.ai)

*Sécurité des machines — Évaluation de l'émission de substances
dangereuses véhiculées par l'air —*

*Partie 5: Méthode sur banc d'essai pour le mesurage de l'efficacité de
séparation massique des systèmes d'épuration d'air avec sortie libre*



PDF disclaimer

This PDF file may contain embedded typefaces. In accordance with Adobe's licensing policy, this file may be printed or viewed but shall not be edited unless the typefaces which are embedded are licensed to and installed on the computer performing the editing. In downloading this file, parties accept therein the responsibility of not infringing Adobe's licensing policy. The ISO Central Secretariat accepts no liability in this area.

Adobe is a trademark of Adobe Systems Incorporated.

Details of the software products used to create this PDF file can be found in the General Info relative to the file; the PDF-creation parameters were optimized for printing. Every care has been taken to ensure that the file is suitable for use by ISO member bodies. In the unlikely event that a problem relating to it is found, please inform the Central Secretariat at the address given below.

iTeh STANDARD PREVIEW
(standards.iteh.ai)

[ISO 29042-5:2010](https://standards.iteh.ai/catalog/standards/sist/c3043e43-f773-42ea-9aba-5ec42529a765/iso-29042-5-2010)

<https://standards.iteh.ai/catalog/standards/sist/c3043e43-f773-42ea-9aba-5ec42529a765/iso-29042-5-2010>



COPYRIGHT PROTECTED DOCUMENT

© ISO 2010

All rights reserved. Unless otherwise specified, no part of this publication may be reproduced or utilized in any form or by any means, electronic or mechanical, including photocopying and microfilm, without permission in writing from either ISO at the address below or ISO's member body in the country of the requester.

ISO copyright office
Case postale 56 • CH-1211 Geneva 20
Tel. + 41 22 749 01 11
Fax + 41 22 749 09 47
E-mail copyright@iso.org
Web www.iso.org

Published in Switzerland

Foreword

ISO (the International Organization for Standardization) is a worldwide federation of national standards bodies (ISO member bodies). The work of preparing International Standards is normally carried out through ISO technical committees. Each member body interested in a subject for which a technical committee has been established has the right to be represented on that committee. International organizations, governmental and non-governmental, in liaison with ISO, also take part in the work. ISO collaborates closely with the International Electrotechnical Commission (IEC) on all matters of electrotechnical standardization.

International Standards are drafted in accordance with the rules given in the ISO/IEC Directives, Part 2.

The main task of technical committees is to prepare International Standards. Draft International Standards adopted by the technical committees are circulated to the member bodies for voting. Publication as an International Standard requires approval by at least 75 % of the member bodies casting a vote.

Attention is drawn to the possibility that some of the elements of this document may be the subject of patent rights. ISO shall not be held responsible for identifying any or all such patent rights.

ISO 29042-5 was prepared by Technical Committee ISO/TC 199, *Safety of machinery*.

ISO 29042 consists of the following parts, under the general title *Safety of machinery — Evaluation of the emission of airborne hazardous substances*:

- PRE-STANDARD PREVIEW
(standards.iteh.ai)
- *Part 1: Selection of test methods*
 - *Part 2: Tracer gas method for the measurement of the emission rate of a given pollutant*
 - *Part 3: Test bench method for the measurement of the emission rate of a given pollutant*
 - *Part 4: Tracer method for the measurement of the capture efficiency of an exhaust system*
 - *Part 5: Test bench method for the measurement of the separation efficiency by mass of air cleaning systems with unducted outlet*
 - *Part 6: Test bench method for the measurement of the separation efficiency by mass of air cleaning systems with ducted outlet*
 - *Part 7: Test bench method for the measurement of the pollutant concentration parameter*

A room method for the measurement of the pollutant concentration parameter and a decontamination index are to form the subjects of future parts 8 and 9.

Introduction

The structure of safety standards in the field of machinery is as follows:

- a) type-A standards (basic safety standards) giving basic concepts, principles for design, and general aspects that can be applied to all machinery;
- b) type-B standards (generic safety standards) dealing with one safety aspect or one type of safeguard that can be used across a wide range of machinery:
 - type-B1 standards on particular safety aspects (e.g. safety distances, surface temperature, noise);
 - type-B2 standards on safeguards (e.g. two-hand controls, interlocking devices, pressure sensitive devices, guards);
- c) type-C standards (machine safety standards) dealing with detailed safety requirements for a particular machine or group of machines.

This part of ISO 29042 is a type-B standard as stated in ISO 12100.

The requirements of this document can be supplemented or modified by a type-C standard.

For machines which are covered by the scope of a type-C standard and which have been designed and built according to the requirements of that standard, the requirements of that type-C standard take precedence.

ISO/TC 199 has a mandate in this area to produce type-A and type-B standards, which will allow verification of conformity with the essential safety requirements.

ISO 29042-5 is based on EN 1093-6:1998, amended by Amendment 1:2008, published by the European Committee for Standardization (CEN).

Safety of machinery — Evaluation of the emission of airborne hazardous substances —

Part 5:

Test bench method for the measurement of the separation efficiency by mass of air cleaning systems with unducted outlet

1 Scope

This part of ISO 29042 specifies a test bench method for the measurement of the separation efficiency by mass of an air cleaning system with an unducted outlet, operating under defined conditions. The method is applicable to those systems that clean the air of aerosols (smoke, dust, fume, mist), vapour or gas.

Measurement of the separation efficiency by mass of an air cleaning system for an intended use can serve for the

- iTeh STANDARD PREVIEW**
(standards.iteh.ai)
- evaluation of the performance of the air cleaning system,
 - evaluation of the improvement of the air cleaning system,
[ISO 29042-5:2010](#)
 - comparison of air cleaning systems,
[http://www.iso.org/iso/catalog/standards/sist/c3043e43-f773-42ea-9aba-5ec42529a765/iso-29042-5-2010](#)
 - ranking of air cleaning systems according to their separation efficiency by mass, and
 - determination of the state of the art of air cleaning systems of the same intended use with respect to their separation efficiency by mass.

2 Normative references

The following referenced documents are indispensable for the application of this document. For dated references, only the edition cited applies. For undated references, the latest edition of the referenced document (including any amendments) applies.

ISO 12100, *Safety of machinery — General principles for design — Risk assessment and risk reduction*

3 Terms and definitions

For the purposes of this document, the terms and definitions given in ISO 12100 and the following apply.

3.1 separation efficiency by mass

η_s
 (air cleaning system) for a given pollutant, the ratio of the mass of pollutant retained by the air cleaning system (m_3) to the mass of pollutant entering the air cleaning system (m_1) during a given period

NOTE The separation efficiency of an air cleaning system as a percentage is expressed as follows:

$$\eta_s = \frac{m_3}{m_1} \times 100 \tag{1}$$

4 Principle

The principle of the measurement method is to operate the air cleaning system under defined conditions in a test bench and to determine the mass of the test substance in the air upstream and downstream of the air cleaning system.

The test substance, which can be the real pollutant or a surrogate, should preferably be of low toxicity and compatible with the objectives of the method.

iTeh STANDARD PREVIEW

5 Description of the test bench (standards.iteh.ai)

The test bench consists of a cabin symmetrically connected to a measurement duct through which air is drawn (see Figures 1 and 2).

<https://standards.iteh.ai/catalog/standards/sist/c3043e43-f773-42ea-9aba-5ec42529a765/iso-29042-5-2010>

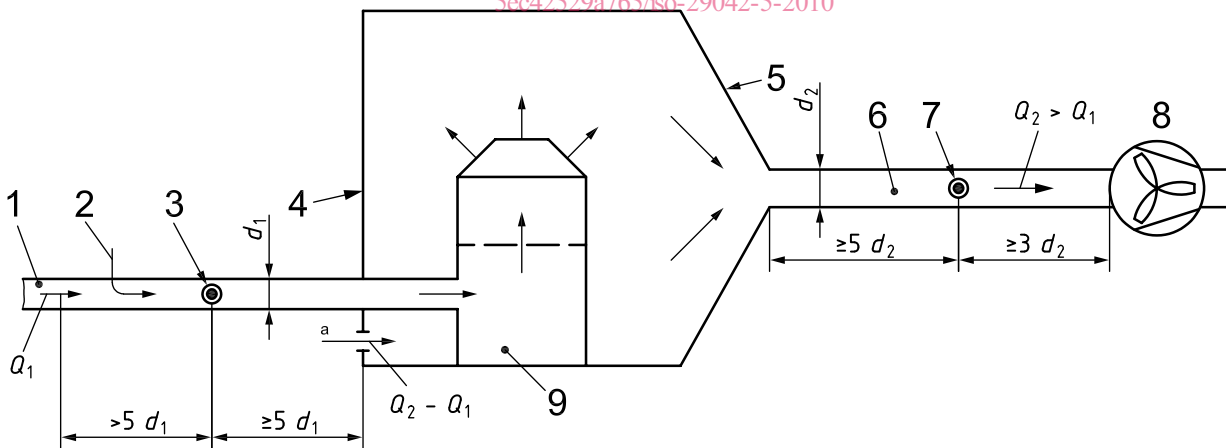

Key

- | | |
|--|----------------------------------|
| 1 inlet duct | 6 outlet duct |
| 2 injection point(s) of test substance | 7 measurement plane 2 |
| 3 measurement plane 1 | 8 air mover |
| 4 test cabin | 9 air cleaning system under test |
| 5 funnel | |
| d_1 diameter of inlet | d_2 diameter of outlet |
| a Secondary air inlet. | |

Figure 1 — Test bench with secondary air inlet

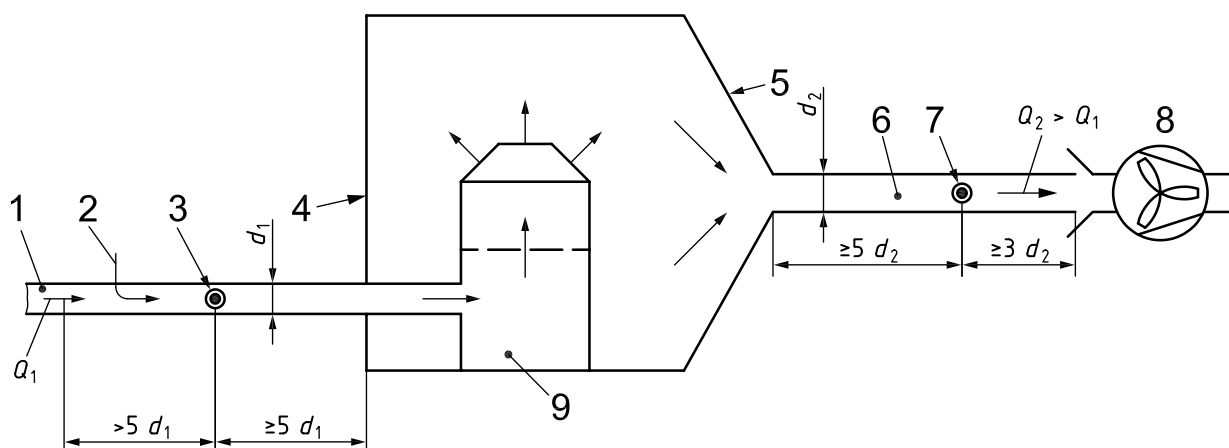
**Key**

1	inlet duct	6	outlet duct
2	injection point(s) of test substance	7	measurement plane 2
3	measurement plane 1	8	air mover
4	test cabin	9	air cleaning system under test
5	funnel		
d_1	diameter of inlet	d_2	diameter of outlet

Figure 2 — Test bench without secondary air inlet

For measurement of the concentration in the inlet duct, an even distribution of the test substance shall be achieved.

The air volume flow rate of the air cleaning system, Q_1 , and the exhaust air flow rate, Q_2 , shall remain constant during the test within stated limits. The cross-section of the test cabin shall be chosen according to the requirements of the air cleaning system.

6 Position and operation of the air cleaning system

To optimize the transport of any pollutant emitted from the air cleaning system to measurement plane 2 (see Figures 1 and 2) in the outlet duct, the air cleaning system should normally be positioned in the test cabin such that the emission from the air cleaning system is in the region of the vertical plane of the longitudinal axis of the outlet duct.

Attention shall be given to the aerodynamic conditions in the test cabin and duct to ensure that there is no significant deposition of pollutant between the air cleaning system and measurement plane 2.

The air cleaning system shall be operated according to its intended use and with a specified test substance. For given categories of air cleaning systems, properties of the test substance (e.g. nature, particle size distribution) and its upstream concentration shall be defined in appropriate type-C standards (see Introduction).

The air cleaning system shall be operated in accordance with the manufacturer's instructions for use.

7 Procedure

The mass flow rate of the test substance shall be determined in the inlet duct from times t_1 to t_2 and in the outlet duct from times t_1 to t_3 . In the inlet duct this mass flow rate can be determined from the mass of test substance feed and the air flow rate. Time t_3 shall be later than time t_2 and shall take into account the time constants of air cleaning system, test cabin and outlet duct. In practical terms the difference between times t_2 and t_3 may be very short in comparison with the measurement time and may have no effect on the measurement result.

The measurement procedures used shall comply with appropriate International Standards. For the measurement of the air flow rate, see ISO 3966, ISO 4006, ISO 5167-1 and ISO 5168¹⁾. The same type of instrument should be used both upstream and downstream of the air cleaning system. If this is not possible, the relationship between the two instruments shall be established for each test substance used.

For certain applications it is useful to determine the separation efficiency according to particle size distribution (see ISO 7708).

The separation efficiency of some air cleaning systems changes with time, e.g. filters. The sampling procedure shall take into account these changing efficiencies in order to obtain valid information about the efficiency of the separator in use.

The measurement time shall be of sufficient duration to allow collection of samples of the test substance emitted during the representative use of the air cleaning system, including, for example, several cycles of the operations of a filter cleaning mechanism.

In general, the separation efficiency of a system is dependent on the amount of retained pollutant and the air volume flow rate. Tests shall therefore be carried out with the various combinations of pollutant amounts and air flow rates which are expected in operation.

Detailed test conditions and statistical analysis of the results shall be specified in appropriate type-C standards.

8 Expression of results

The separation efficiency, η_s , of an air cleaning system is calculated as a percentage according to Equation (2):

$$\eta_s = \frac{m_3}{m_1} \cdot 100 = \left[1 - \frac{m_2}{m_1} \right] \cdot 100 = \left[1 - \frac{\int_{t_1}^{t_2} Q_1 \cdot C_1 dt}{\int_{t_1}^{t_3} Q_2 \cdot C_2 dt} \right] \cdot 100 \quad (2)$$

where

m_1 is the mass of the test substance entering the air cleaning system;

m_2 is the mass of the test substance not retained by the air cleaning system;

1) In EN 1093-6, on which this part of ISO 29042 is based, reference was made to ISO 4053-1:1977 and ISO 7145:1982. Both International Standards have since been withdrawn and are no longer publicly available; at the time of publication of this part of ISO 29042, they had not been replaced by other International Standards.

m_3 is the mass of the test substance retained by the air cleaning system;

C_1 is the mass concentration of the test substance entering the air cleaning system;

C_2 is the mass concentration of the test substance at measurement plane 2;

Q_1 is the air volume flow rate in the inlet duct;

Q_2 is the air volume flow rate in the outlet duct.

When the separation efficiency is required as a function of particle size distribution, m_1 and m_2 are measured for each particle size range of interest.

9 Test report

The test report shall include at least the following information:

- a) reference to this part of ISO 29042 ("ISO 29042-5:2010") and any associated type-C standards;
- b) description of the air cleaning system tested (manufacturer, model, type, version, design, size, year of manufacture, serial number, etc.);
- c) operational data during tests, including air flow rates;
- d) test substance (nature, concentration and, for dusts, particle size distribution, moisture content, etc.);
- e) description of measurement procedures, including type of test bench used;
- f) measuring instruments used and their most recent calibration dates;
- g) environmental data (temperature, humidity, atmospheric pressure);
- h) description of the procedures used (e.g. list of standards) for concentration and flow rate measurements;
- i) test results;
- j) any comments on deviations from any relevant standards;
- k) test laboratory;
- l) name of the person responsible for carrying out the test;
- m) date of testing;
- n) any additional comments.