**Safety of machinery — Evaluation of the
emission of airborne hazardous
substances —**

Part 7:

**Test bench method for the measurement
of the pollutant concentration parameter**

iTeh STANDARD PREVIEW

(standards.iteh.ai)

*Sécurité des machines — Évaluation de l'émission de substances
dangereuses véhiculées par l'air —*

*Partie 7: Méthode sur banc d'essai pour le mesurage du paramètre de
concentration en polluant*

<https://standards.iteh.ai/catalog/standards/sist/e980e1d0-8958-48dd-ae8d-bc643704a532/iso-29042-7-2010>



PDF disclaimer

This PDF file may contain embedded typefaces. In accordance with Adobe's licensing policy, this file may be printed or viewed but shall not be edited unless the typefaces which are embedded are licensed to and installed on the computer performing the editing. In downloading this file, parties accept therein the responsibility of not infringing Adobe's licensing policy. The ISO Central Secretariat accepts no liability in this area.

Adobe is a trademark of Adobe Systems Incorporated.

Details of the software products used to create this PDF file can be found in the General Info relative to the file; the PDF-creation parameters were optimized for printing. Every care has been taken to ensure that the file is suitable for use by ISO member bodies. In the unlikely event that a problem relating to it is found, please inform the Central Secretariat at the address given below.

iTeh STANDARD PREVIEW
(standards.iteh.ai)

ISO 29042-7:2010

<https://standards.iteh.ai/catalog/standards/sist/e980e1d0-8958-48dd-ae8d-bc643704a532/iso-29042-7-2010>



COPYRIGHT PROTECTED DOCUMENT

© ISO 2010

All rights reserved. Unless otherwise specified, no part of this publication may be reproduced or utilized in any form or by any means, electronic or mechanical, including photocopying and microfilm, without permission in writing from either ISO at the address below or ISO's member body in the country of the requester.

ISO copyright office
Case postale 56 • CH-1211 Geneva 20
Tel. + 41 22 749 01 11
Fax + 41 22 749 09 47
E-mail copyright@iso.org
Web www.iso.org

Published in Switzerland

Foreword

ISO (the International Organization for Standardization) is a worldwide federation of national standards bodies (ISO member bodies). The work of preparing International Standards is normally carried out through ISO technical committees. Each member body interested in a subject for which a technical committee has been established has the right to be represented on that committee. International organizations, governmental and non-governmental, in liaison with ISO, also take part in the work. ISO collaborates closely with the International Electrotechnical Commission (IEC) on all matters of electrotechnical standardization.

International Standards are drafted in accordance with the rules given in the ISO/IEC Directives, Part 2.

The main task of technical committees is to prepare International Standards. Draft International Standards adopted by the technical committees are circulated to the member bodies for voting. Publication as an International Standard requires approval by at least 75 % of the member bodies casting a vote.

Attention is drawn to the possibility that some of the elements of this document may be the subject of patent rights. ISO shall not be held responsible for identifying any or all such patent rights.

ISO 29042-7 was prepared by Technical Committee ISO/TC 199, *Safety of machinery*.

ISO 29042 consists of the following parts, under the general title *Safety of machinery — Evaluation of the emission of airborne hazardous substances*:

- PRE-STANDARD PREVIEW
(standards.iteh.ai)
- Part 1: Selection of test methods
 - Part 2: Tracer gas method for the measurement of the emission rate of a given pollutant
 - Part 3: Test bench method for the measurement of the emission rate of a given pollutant
 - Part 4: Tracer method for the measurement of the capture efficiency of an exhaust system
 - Part 5: Test bench method for the measurement of the separation efficiency by mass of air cleaning systems with unducted outlet
 - Part 6: Test bench method for the measurement of the separation efficiency by mass of air cleaning systems with ducted outlet
 - Part 7: Test bench method for the measurement of the pollutant concentration parameter

A room method for the measurement of the pollutant concentration parameter and a decontamination index are to form the subjects of future parts 8 and 9.

Introduction

The structure of safety standards in the field of machinery is as follows:

- a) type-A standards (basic safety standards) giving basic concepts, principles for design, and general aspects that can be applied to all machinery;
- b) type-B standards (generic safety standards) dealing with one safety aspect or one type of safeguard that can be used across a wide range of machinery:
 - type-B1 standards on particular safety aspects (e.g. safety distances, surface temperature, noise);
 - type-B2 standards on safeguards (e.g. two-hand controls, interlocking devices, pressure sensitive devices, guards);
- c) type-C standards (machine safety standards) dealing with detailed safety requirements for a particular machine or group of machines.

This part of ISO 29042 is a type-B standard as stated in ISO 12100.

The requirements of this document can be supplemented or modified by a type-C standard.

For machines which are covered by the scope of a type-C standard and which have been designed and built according to the requirements of that standard, the requirements of that type-C standard take precedence.

ISO/TC 199 has a mandate in this area to produce type-A and type-B standards, which will allow verification of conformity with the essential safety requirements.

ISO 29042-7 is based on EN 1093-8:1998, amended by Amendment 1:2008, published by the European Committee for Standardization (CEN).

Safety of machinery — Evaluation of the emission of airborne hazardous substances —

Part 7: Test bench method for the measurement of the pollutant concentration parameter

1 Scope

This part of ISO 29042 specifies a test bench method for the measurement of the pollutant concentration parameter of a given airborne hazardous substance from a machine, using a test bench under specified operating conditions. The method is applicable only to the determination of emitted gases, vapours and respirable particles. It is intended that whenever possible the emission rate be determined in a test bench (see ISO 29042-3).

Measurement of the pollutant concentration parameter of a machine can serve for the

- a) evaluation of the performance of the machine,
- b) evaluation of the improvement of the machine,
- c) comparison of machines within different groups of machines with the same intended use (such groups being defined by the function and materials processed),
- d) ranking of machines from the same group according to their pollutant concentration parameters, and
- e) determination of the state of the art of a machine with respect to its pollutant concentration parameter.

2 Normative references

The following referenced documents are indispensable for the application of this document. For dated references, only the edition cited applies. For undated references, the latest edition of the referenced document (including any amendments) applies.

ISO 2602, *Statistical interpretation of test results — Estimation of the mean — Confidence interval*

ISO 12100, *Safety of machinery — General principles for design — Risk assessment and risk reduction*

3 Terms and definitions

For the purposes of this document, the terms and definitions given in ISO 12100 and the following apply.

3.1 pollutant concentration parameter of the cabin

P_{cc}
measured concentration of a given pollutant in defined position(s) near the machine

NOTE For the purposes of this part of ISO 29042, one measurement plane is used, preferably in the exhaust duct.

4 Principle

The principle of the measurement method is to operate machines under controlled conditions in a test bench and measure the pollutant concentration at a well-defined location (see 5.2) for a specified exhaust air flow rate of the test bench. This concentration gives an indication of the emission from the machine.

5 Test bench

5.1 Description of the test bench

The test bench consists of a test cabin with a funnel and a subsequent air mover (see Figure 1).

The air mover produces an air flow in the test cabin from the inlet towards the funnel. The test cabin shall be equipped with a permeable inlet (for example, macroporous filter material, perforated plastic foil or plate) in order to obtain a uniform air flow across the inlet and to avoid escape of the pollutant from the test cabin.

The test cabin exhaust flow rate shall be specified in type-C standards. It shall be controlled in order to remain constant. The cross-section of the test cabin (form and dimensions) shall be chosen according to the size of the machine. The maximum cross-sectional area of the machine shall not exceed a fifth of the cross-sectional area of the test cabin.

The test cabin shall be long enough to accommodate the machine and the operator, with the emission sources as close to the specified location as practicable, according to Figure 1.

The machine shall be positioned in the test cabin such that the source of the pollutant emitted from the machine is in the area of the longitudinal axis of the test cabin at a distance, l_1 , from the beginning of the funnel and a distance, l_0 , from the inlet, as shown in Figure 1.

5.2 Location of measurement planes

The concentration of the pollutant shall be measured at measurement plane 1 in the exhaust duct.

Alternatively, if it is necessary to use measuring instruments having larger sampling heads and/or suitable only for lower air velocities, then measurement plane 2, located in the area of the middle axis of the funnel as near as possible to the exhaust duct, may be used.

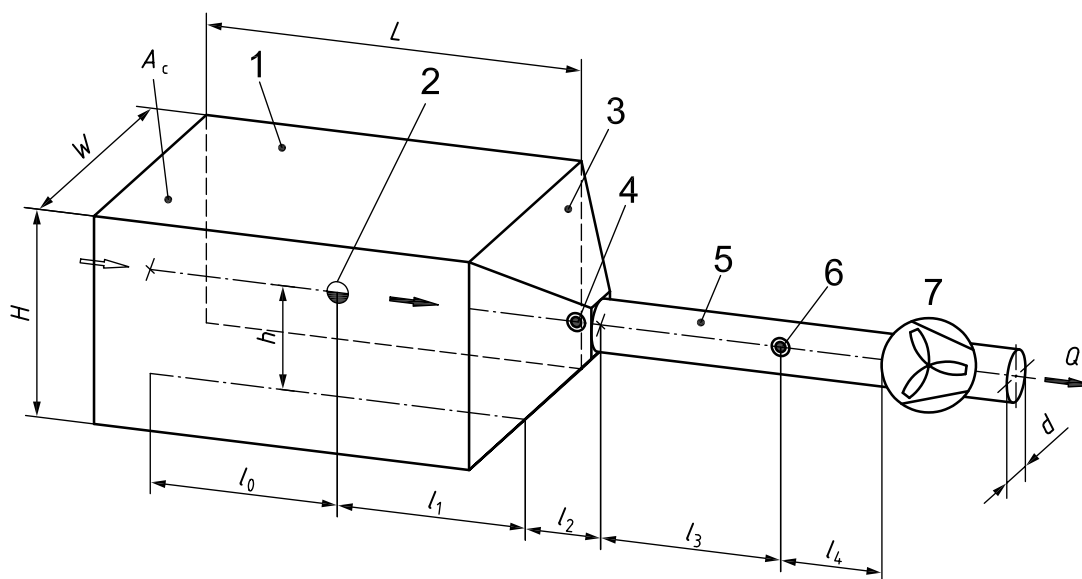

$W/H \geq 0,66$	$l_1 \geq 0,5\sqrt{A_c}$	$l_3 \geq 5d$
$\leq 1,5$	$\leq 2,0\sqrt{A_c}$	$l_4 \geq 3d$
$h \leq 0,66H$	$\leq 2,0 \text{ m}$	
$l_0 \geq 0,5\sqrt{A_c}$	$l_2 \geq 0,5\sqrt{A_c}$	
	$\leq \sqrt{A_c}$	

Key

1 test cabin	A_c cross-section of test cabin
2 emission source	d diameter of outlet
3 funnel	H height of test cabin
4 measurement plane 2	h height of emission source
5 exhaust duct	L length of test cabin
6 measurement plane 1 (preferred)	Q_E cabin exhaust flow rate
7 air mover	W width of test cabin

NOTE Generally, the emission source cannot be considered as a point, but as a zone including several sources.

Figure 1 — Test bench (schematic layout)

6 Procedure

6.1 Operation of machine

The machine shall be operated according to its intended use. The stipulation of working procedures, the tools used and the materials to be processed with specified categories of machines will be defined in type-C standards.

If the machine is equipped with its own separator, re-circulating air towards the working zone depending on the intended use, the outlet of the separator shall be located in the test cabin so as to ensure that the pollutant from this secondary source reaches the measurement plane.

The machine shall be operated in accordance with the manufacturer's instructions. When the machine is provided with a pollutant control system this shall be adjusted according to these instructions.

Tests shall not be carried out unless manufacturer's specifications for operating the pollutant control system are available.

6.2 Measurement procedures

The measurement procedures used for the pollutant concentration shall comply with the appropriate International Standards. Detailed procedures shall be specified in the appropriate type-C standards for each type of machine.

The measurement shall take into account the normal operational cycles of the machine.

The measurement time shall be sufficient to enable the collection of concentration data representative of the normal operational cycles of the machine.

At least three tests shall be performed.

7 Expression of results

The pollutant concentration parameter of the cabin, P_{CC} , is the sum of the mean value and the 95 % confidence interval according to ISO 2602.

8 Test report

The test report shall include at least the following information:

- a) reference to this part of ISO 29042 ("ISO 29042-7:2010") and any associated type-C standards;
- b) description of the machine tested (manufacturer, model, type, version, design, size, year of manufacture, serial number, etc.) — for the machine itself and for each additional piece of equipment;
- c) operational data during tests, including tools used with the machine and the material processed on the machine;
<https://standards.iteh.ai/catalog/standards/sist/e980e1d0-8958-48dd-ae8d-bc643704a532/iso-29042-7-2010>
- d) description of the pollutant control system (manufacturer, model, type, version, design, size, year of manufacture, serial number, operational data, etc.);
- e) test cabin exhaust flow rate;
- f) description of measurement procedures, including the locations of the measurement plane and pollutant measured;
- g) measuring instruments used and their most recent calibration date;
- h) environmental data (temperature, humidity, atmospheric pressure);
- i) description of procedures used (e.g. list of standards) for concentration and flow rate measurements;
- j) number of tests performed;
- k) measured concentrations;
- l) pollutant concentration parameter of the cabin, P_{CC} , mean value and 95 % confidence interval;
- m) any comments on deviations from any relevant standards;
- n) test laboratory;
- o) name of the person responsible for carrying out the test;
- p) date of testing;
- q) any additional comments.

Bibliography

- [1] ISO 29042-3, *Safety of machinery — Evaluation of the emission of airborne hazardous substances — Part 3: Test bench method for the measurement of the emission rate of a given pollutant*

iTeh STANDARD PREVIEW
(standards.iteh.ai)

[ISO 29042-7:2010](https://standards.iteh.ai/catalog/standards/sist/e980e1d0-8958-48dd-ae8d-bc643704a532/iso-29042-7-2010)

<https://standards.iteh.ai/catalog/standards/sist/e980e1d0-8958-48dd-ae8d-bc643704a532/iso-29042-7-2010>