

---

**Varnost lesnoobdelovalnih strojev - Krožne žage - 8. del: Enolistne obrezovalne krožne žage s pogonsko enoto in ročnim podajanjem in/ali odvzemom**

Safety of woodworking machines - Circular sawing machines - Part 8: Single blade edging circular rip sawing machines with power driven saw unit and manual loading and/or unloading

Sicherheit von Holzbearbeitungsmaschinen - Kreissägemaschinen - Teil 8: Einblattbesäum- und Leistenkreissägemaschinen mit kraftbetätigtem Sägeaggregat und Handbeschickung und/oder Handentnahme

Sécurité des machines pour le travail du bois - Machines à scier circulaires - Partie 8: Déligneuses monolames à déplacement mécanisé du groupe de sciage et à chargement manuel et/ou déchargement manuel

**Ta slovenski standard je istoveten z: EN 1870-8:2001**

---

**ICS:**

25.080.60	Strojne žage	Sawing machines
79.120.10	Lesnoobdelovalni stroji	Woodworking machines

**SIST EN 1870-8:2002** en

**iTeh STANDARD PREVIEW**  
**(standards.iteh.ai)**

SIST EN 1870-8:2002

<https://standards.iteh.ai/catalog/standards/sist/77c8ebc3-c649-45a8-9c57-c915b4bc12a5/sist-en-1870-8-2002>

EUROPEAN STANDARD  
NORME EUROPÉENNE  
EUROPÄISCHE NORM

**EN 1870-8**

October 2001

ICS 79.120.10

English version

**Safety of woodworking machines - Circular sawing machines -  
Part 8: Single blade edging circular rip sawing machines with  
power driven saw unit and manual loading and/or unloading**

Sécurité des machines pour le travail du bois - Machines à  
scier circulaires - Partie 8: Déligneuses monolames à  
déplacement mécanisé du groupe de sciage et à  
chargement manuel et/ou déchargement manuel

Sicherheit von Holzbearbeitungsmaschinen -  
Kreissägemaschinen - Teil 8: Einblattbesäum- und  
Leistenkreissägemaschinen mit kraftbetätigtem  
Sägeaggregat und Handbeschickung und/oder  
Handentnahme

This European Standard was approved by CEN on 30 September 2001.

CEN members are bound to comply with the CEN/CENELEC Internal Regulations which stipulate the conditions for giving this European Standard the status of a national standard without any alteration. Up-to-date lists and bibliographical references concerning such national standards may be obtained on application to the Management Centre or to any CEN member.

This European Standard exists in three official versions (English, French, German). A version in any other language made by translation under the responsibility of a CEN member into its own language and notified to the Management Centre has the same status as the official versions.

CEN members are the national standards bodies of Austria, Belgium, Czech Republic, Denmark, Finland, France, Germany, Greece, Iceland, Ireland, Italy, Luxembourg, Netherlands, Norway, Portugal, Spain, Sweden, Switzerland and United Kingdom.



EUROPEAN COMMITTEE FOR STANDARDIZATION  
COMITÉ EUROPÉEN DE NORMALISATION  
EUROPÄISCHES KOMITEE FÜR NORMUNG

**Management Centre: rue de Stassart, 36 B-1050 Brussels**

**iTeh STANDARD PREVIEW**  
**(standards.iteh.ai)**

SIST EN 1870-8:2002

<https://standards.iteh.ai/catalog/standards/sist/77c8ebc3-c649-45a8-9c57-c915b4bc12a5/sist-en-1870-8-2002>

**iTeh STANDARD PREVIEW**  
**(standards.iteh.ai)**

SIST EN 1870-8:2002

<https://standards.iteh.ai/catalog/standards/sist/77c8ebc3-c649-45a8-9c57-c915b4bc12a5/sist-en-1870-8-2002>

**iTeh STANDARD PREVIEW**  
**(standards.iteh.ai)**

SIST EN 1870-8:2002

<https://standards.iteh.ai/catalog/standards/sist/77c8ebc3-c649-45a8-9c57-c915b4bc12a5/sist-en-1870-8-2002>

**iTeh STANDARD PREVIEW**  
**(standards.iteh.ai)**

SIST EN 1870-8:2002

<https://standards.iteh.ai/catalog/standards/sist/77c8ebc3-c649-45a8-9c57-c915b4bc12a5/sist-en-1870-8-2002>

**iTeh STANDARD PREVIEW**  
**(standards.iteh.ai)**

SIST EN 1870-8:2002

<https://standards.iteh.ai/catalog/standards/sist/77c8ebc3-c649-45a8-9c57-c915b4bc12a5/sist-en-1870-8-2002>



**iTeh STANDARD PREVIEW**  
**(standards.iteh.ai)**

SIST EN 1870-8:2002

<https://standards.iteh.ai/catalog/standards/sist/77c8ebc3-c649-45a8-9c57-c915b4bc12a5/sist-en-1870-8-2002>

**iTeh STANDARD PREVIEW**  
**(standards.iteh.ai)**

SIST EN 1870-8:2002

<https://standards.iteh.ai/catalog/standards/sist/77c8ebc3-c649-45a8-9c57-c915b4bc12a5/sist-en-1870-8-2002>

## iTeh STANDARD PREVIEW (standards.iteh.ai)

SIST EN 1870-8:2002

<https://standards.iteh.ai/catalog/standards/sist/77c8ebc3-c649-45a8-9c57-c915b4bc12a5/sist-en-1870-8-2002>

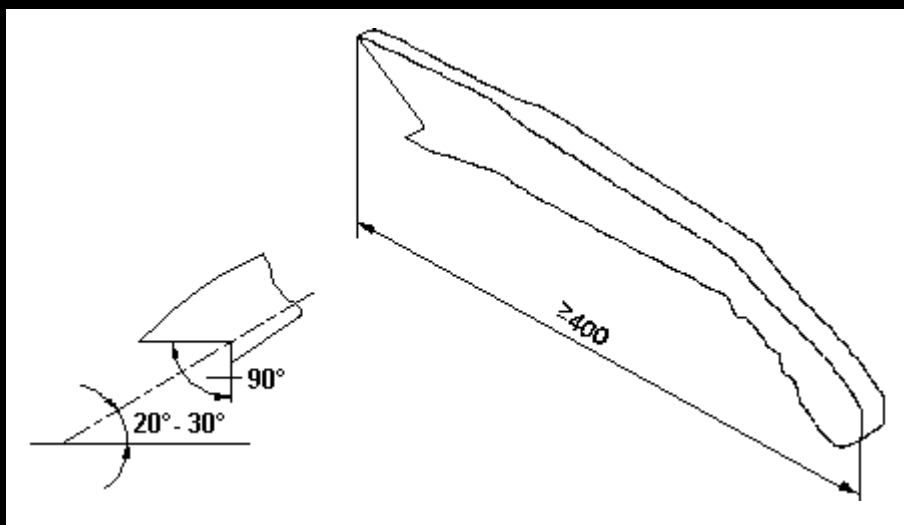

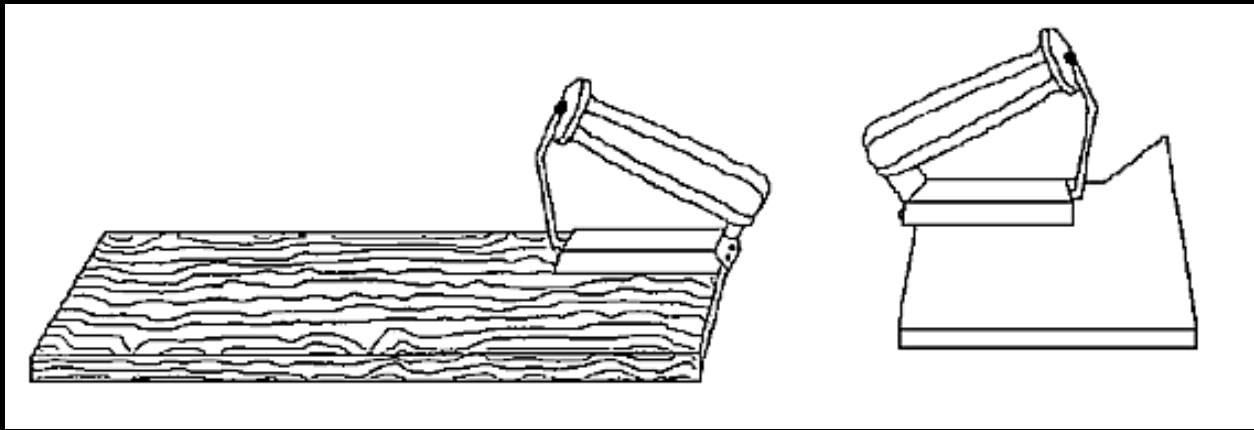

**iTeh STANDARD PREVIEW**  
**(standards.iteh.ai)**

SIST EN 1870-8:2002

<https://standards.iteh.ai/catalog/standards/sist/77c8cbc3-c649-45a8-9c57-c915b4bc12a5/sist-en-1870-8-2002>

**iTeh STANDARD PREVIEW**  
**(standards.iteh.ai)**

SIST EN 1870-8:2002

<https://standards.iteh.ai/catalog/standards/sist/77c8ebc3-c649-45a8-9c57-c915b4bc12a5/sist-en-1870-8-2002>