



Designation: D 3957 – 90 (Reapproved 1996)^{ε1}

Standard Practices for Establishing Stress Grades for Structural Members Used in Log Buildings¹

This standard is issued under the fixed designation D 3957; the number immediately following the designation indicates the year of original adoption or, in the case of revision, the year of last revision. A number in parentheses indicates the year of last reapproval. A superscript epsilon (ϵ) indicates an editorial change since the last revision or reapproval.

^{ε1} NOTE—Keywords were added in July 1996.

INTRODUCTION

These practices are based on the assumption that structural members in log buildings can be stress-graded by methods that derive from accepted standards for conventional solid sawn lumber and round timbers. It is assumed that the material to be graded bears enough similarity to either sawn lumber or round timber, both in dimensional properties and in use, to warrant application of stress-grading standards written for sawn-lumber or round-timber, or both. These practices, such as Practice D 245 and Method D 2899, cannot be applied directly because the structural members used in log buildings are generally neither perfectly rectangular nor perfectly round in section. These practices use certain conventions regarding cross-sectional dimensions that make it possible to extend established stress-grading methodologies to cover the members used in log buildings.

Where log member characteristics deviate from sawn lumber or round timber standards, there may be uncertainty as to the exact effect of the deviation on strength properties. To compensate for this uncertainty, some design stress values are herein derived with practices that are, by engineering judgment, conservative. The philosophy guiding this approach is that while the absence of experimental data may make a measure of conservatism unavoidable, the reliability of design stress values must not be achieved through wood quality or size requirements that are an unnecessary burden on the wood resource.

In general, the sawing, cutting, and shaving required to bring a piece to its final shape must be completed before it can be visually graded using the principles in this standard. Small cuts may be allowed after grading if it can be shown that either (1) the cuts do not affect the grade, or (2) the grade takes the additional cuts into consideration.

Both sawn lumber standards and round timber standards are herein referenced, because these two stress-grading methodologies can be assumed to apply to two different types of structural members used in log buildings: wall-logs and round timber beams. Since wall-logs must be provided with a means of joining together (for example, tongue-and-groove joints), they resemble sawn lumber and are treated as such in the standard. Rafters, purlins, and beams, on the other hand, are sometimes left as round logs, except for a small amount of sawing to provide a flat nailing surface. These practices thus deal with stress-grading of wall-logs and round-timber beams separately.

1. Scope

1.1 These practices cover the visual stress-grading principles applicable to structural wood members of nonrectangular shape, as typically used in log buildings. These practices are meant to supplement the ASTM standards listed below, which cover stress-grading of sawn lumber and round timbers. Pieces

covered by these practices may also be used in building types other than log buildings.

1.2 The grading provisions used as illustrations herein are not intended to establish grades for purchase, but rather to show how stress-grading principles are applied to members used in log buildings. Detailed grading rules for commercial stress grades which serve as purchase specifications are established and published by agencies that formulate and maintain such rules and operate inspection facilities covering the various species.

1.3 *This standard does not purport to address all of the safety concerns, if any, associated with its use. It is the*

¹ These practices are under the jurisdiction of ASTM Committee D-7 on Wood and are the direct responsibility of Subcommittee D07.02 on Lumber and Engineered Wood Products.

Current edition approved April 27, 1990. Published May 1990. Originally published as D 3957 – 80. Last previous edition D 3957 – 80 (1984).

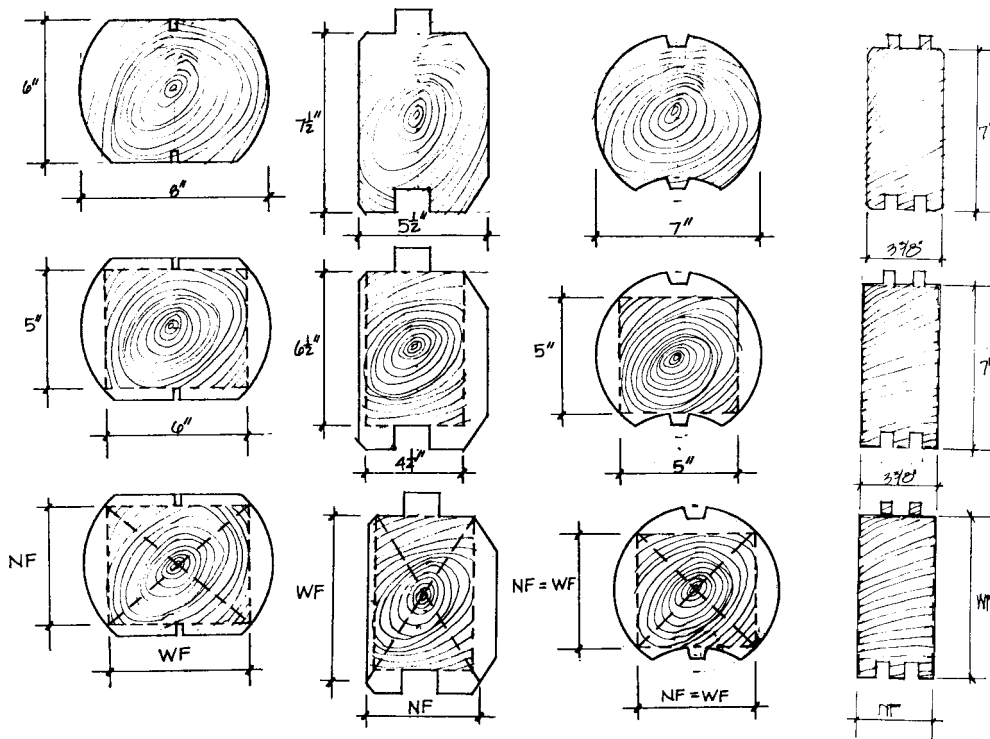

NF—Narrow Face
WF—Wide Face

FIG. 1 Typical Wall-Log Sections Showing Wide and Narrow Faces as Determined by Inscribed Rectangle

responsibility of the user of this standard to establish appropriate safety and health practices and determine the applicability of regulatory limitations prior to use.

2. Referenced Documents

2.1 ASTM Standards:

- D 9 Terminology Relating to Wood²
- D 25 Specification for Round Timber Piles²
- D 245 Practice for Establishing Structural Grades and Related Allowable Properties for Visually Graded Lumber²
- D 2555 Test Methods for Establishing Clear Wood Strength Values²
- D 2899 Method for Establishing Design Stresses for Round Timber Piles²
- D 3200 Specification and Methods for Establishing Recommended Design Stresses for Round Timber Construction Poles²

3. Stress-Grading of Wall-Logs

3.1 General:

3.1.1 This section is intended to apply to wood members, referred to as wall-logs, which are normally stacked horizontally or laid-up vertically to form a load-bearing, solid-wood wall, in any building. These structural members can vary greatly in dimension and section profile, and therefore previously developed standards for solid sawn lumber are not readily applied to them (Fig. 1).

3.1.2 Wall-logs, as referred to in this standard, can also be used as beams, joists, etc., and do not have to be used as wall components.

3.1.3 Unless they qualify as round-timber beams under Section 4 of this standard, wall-logs must be considered as sawn lumber and therefore must respect the provisions of stress-grading described in Practice D 245. The manner in which Practice D 245 is applied to wall-logs is described in 3.2.

3.2 Use of Rectangular Section Inscribed in Actual Sections:

3.2.1 A wall-log is to be graded as the largest piece of rectangular lumber that can be embedded in the wall-log without protrusion from any wall-log surface except that each corner may protrude up to 1/2 in. in either or both directions (Fig. 2). All provisions of Practice D 245 that would apply to a piece with the same cross section as the inscribed rectangle shall apply to the wall-log.

3.2.2 Maximum knot sizes shall be determined by the wide and narrow face dimensions of the inscribed rectangle, using knot tables in Practice D 245. Boundaries between portions of the wall-log surface considered "wide-face" and portions considered "narrow-face" shall be found by extending the diagonals of the inscribed rectangle to the wall-log surface (Fig. 3). Just as the wide and narrow faces of the inscribed rectangle belong to a quadrant between diagonals, so shall the wide and narrow faces of the wall-log surface belong to the same quadrants. In general, then, the surface boundaries between wide and narrow faces may not coincide with actual edges on the wall-log.

² Annual Book of ASTM Standards, Vol 04.10.

— Narrow face — Wide Face

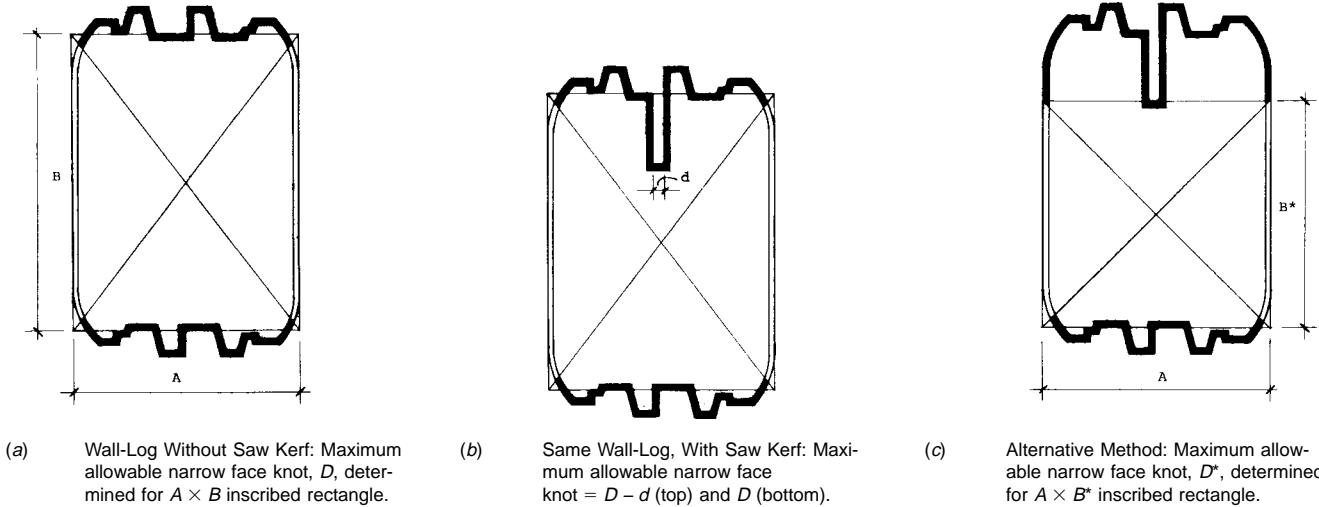

FIG. 2 Determination of Inscribed Rectangle

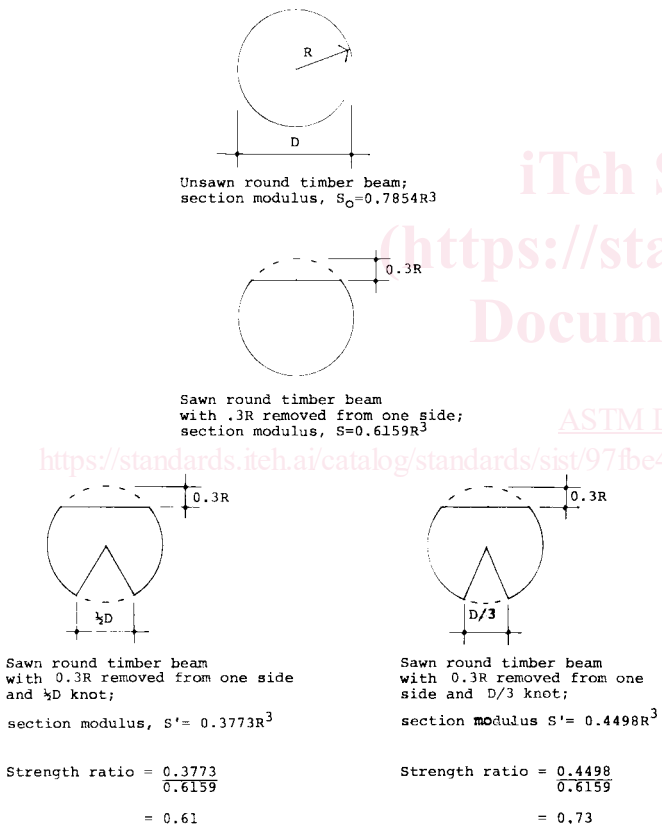

FIG. 3 Strength Ratio for Sawn Round Timber Beam

3.2.3 Knot size limitations, as determined by the dimensions of the inscribed rectangle, shall apply to knot measurements taken at the surface of the wall-log. The slight difference between the knot size at the surface of the wall-log, and the knot size at the inscribed rectangle is, for practical purposes, disregarded.

3.2.4 If the wall-log design has saw-cuts that penetrate deeply into the piece, then any "inscribed rectangle" that remains unpenetrated by sawing may be too small to use for determining knot limitations. To accommodate wall-logs of

this type, cuts into the inscribed rectangle may be treated as follows.

3.2.4.1 If a face of an inscribed rectangle has a maximum allowable knot size of D inches when the face is unpenetrated by any cuts, then the maximum allowable knot size for knots that do not encompass the sawcut is reduced to $D - d$ inches when the face is penetrated by a cut d inches wide. That is, a saw cut $\frac{1}{2}$ in. wide could effectively increase a 2-in. knot to $2\frac{1}{2}$ in., as when the knot and the cut are tangent to each other. Therefore, a cut $\frac{1}{2}$ in. wide will reduce the maximum allowable knot by $\frac{1}{2}$ in. (Fig. 3).

3.2.4.2 As an alternate to 3.2.4.1, reduce the maximum allowable knot displacement D to $D - 2d$ where d is the displacement of the sawcut(s) when the knot does not encompass the sawcut. For example, a 6 by 12 in. with maximum knot displacement of 50 %, and two grooves $\frac{3}{4}$ by 1 in. each on one narrow face, a groove displacement of 2 %, the allowable knot displacement for knots that do not encompass the grooves would be reduced to $50 - 2(2) = 46$ %.

4. Stress-Grading of Sawn Round Timber Beams

4.1 General:

4.1.1 This section describes how the formulas of Method D 2899 are applied to round timbers that are shaved or sawn along one side (Note 1). Since these members are normally loaded on their flat surface, they are stressed primarily in bending and are herein referred to as sawn round timber beams.

NOTE 1—Unsawn round timbers used in the superstructure of buildings are covered by Specification and Methods D 3200.

4.1.2 Specification D 25 and Method D 2899 set forth one structural grade. This standard supplements Specification D 25 and Method D 2899 so that a series of grades can be constructed. This is accomplished by means of the strength ratios defined in 4.5.

4.2 Allowable Sawing:

4.2.1 The flat side of a sawn round timber beam shall not penetrate more than $0.3R$ into the piece, where R is the radius of the beam (Fig. 2). This limits the reduction of the cross-sectional area, by sawing or shaving, to less than 10 %.