

ISO

INTERNATIONAL ORGANIZATION FOR STANDARDIZATION

ISO RECOMMENDATION

R 812

METHOD OF TEST FOR TEMPERATURE LIMIT OF BRITTLINESS
(FOR VULCANIZED RUBBERS)

[ISO/R 812:1968](https://standards.iteh.ai/catalog/standards/sist/90239a05-d9be-487f-87bd-29db97020eb/iso-r-812-1968)

<https://standards.iteh.ai/catalog/standards/sist/90239a05-d9be-487f-87bd-29db97020eb/iso-r-812-1968>

1st EDITION

September 1968

COPYRIGHT RESERVED

The copyright of ISO Recommendations and ISO Standards belongs to ISO Member Bodies. Reproduction of these documents, in any country, may be authorized therefore only by the national standards organization of that country, being a member of ISO.

For each individual country the only valid standard is the national standard of that country.

Printed in Switzerland

Also issued in French and Russian. Copies to be obtained through the national standards organizations.

BRIEF HISTORY

The ISO Recommendation R 812, *Method of test for temperature limit of brittleness for vulcanized rubbers*, was drawn up by Technical Committee ISO/TC 45, *Rubber*, the Secretariat of which is held by the British Standards Institution (BSI).

Work on this question by the Technical Committee led, in 1962, to the adoption of a Draft ISO Recommendation.

In November 1963, this Draft ISO Recommendation (No. 613) was circulated to all the ISO Member Bodies for enquiry. It was approved, subject to a few modifications of an editorial nature, by the following Member Bodies :

Argentina	Germany	Poland
Australia	Hungary	Spain
Austria	India	Sweden
Brazil	Israel	Switzerland
Canada	Italy	United Kingdom
Chile	Japan	U.S.A.
Colombia	Korea, Rep. of	U.S.S.R.
Czechoslovakia	Netherlands	Yugoslavia
France	New Zealand	

No Member Body opposed the approval of the Draft.

The Draft ISO Recommendation was then submitted by correspondence to the ISO Council, which decided, in September 1968, to accept it as an ISO RECOMMENDATION.

FOREWORD

Amendment 1 to ISO Recommendation R 812-1968 was drawn up by Technical Committee ISO/TC 45, *Rubber and rubber products*. As the Members of ISO/TC 45 considered the modifications made to that ISO Recommendation to be of minor importance, this amendment was submitted direct to the ISO Council under the abbreviated procedure set forth in clause F.7.1 of the Directives for the technical work of ISO.

Amendment 1 – June 1972 – to ISO Recommendation R 812-1968**Amendment 1
to ISO Recommendation R 812-1968****METHOD OF TEST FOR TEMPERATURE LIMIT OF BRITTLINESS
FOR VULCANIZED RUBBERS****iTeh STANDARD PREVIEW**

Section 3 : delete the second paragraph and the Note.

Section 4 : clause 4.1.2, delete the second paragraph and replace with the following text :

“A minimum of 6 mm of the length of the test piece (the tab end for type B test pieces) should be held in the clamp.”

A minimum of four test pieces should be tested. The number of test pieces that may be tested during any one impact is limited by the energy capacity of the apparatus and should not cause the rectilinear speed of the striker immediately after the impact to fall below 1.83 m/s.”

Number the note after clause 4.1.2 as “1.” and add a second note :

“2. Four type A test pieces require the same available energy as ten type B test pieces.

For some materials and apparatus it may be necessary to test, at any one impact, a reduced number of test pieces in order to maintain the required rectilinear speed of the striker, immediately after the impact.”

Section 5 : add the following new item :

“(f) The number of test pieces of any given sample tested at a single impact.”

iTeh STANDARD PREVIEW
(standards.iteh.ai)

ISO/R 812:1968

<https://standards.iteh.ai/catalog/standards/sist/90239a05-d9be-487f-87bd-2f9db97020eb/iso-r-812-1968>

METHOD OF TEST FOR TEMPERATURE LIMIT OF BRITTLINESS FOR VULCANIZED RUBBERS

1. SCOPE

This ISO Recommendation describes a method for determining the lowest temperature at which rubber compounds do not exhibit brittle failure when impacted under specified conditions. Brittleness temperatures thus determined are not necessarily indicative of service performance.

NOTE. — Brittleness temperatures of rubbers are empirical points dependent to a large degree upon test procedures and apparatus. In order to obtain reproducible brittleness temperature measurements, all pertinent test variables must be thoroughly defined. The procedure outlined in this ISO Recommendation defines those variables at present known to influence the brittleness test.

2. APPARATUS

- 2.1 *Test piece clamp and striker.* The clamp is designed to hold the test pieces as cantilever beams (see Fig. 1). The striking edge moves relative to the test pieces at a rectilinear speed of 1.83 to 2.13 m per second at and immediately after impact. A motor, solenoid or other type of actuator may be used provided that the radius of the striker, the speed of the striker and the distance from the test piece clamp are as specified.

NOTE. — Two types of tester currently in use are shown in Figures 3 and 4 in the Annex.

The distance between the centre line of the striking edge and the clamp should be 7.9 ± 0.3 mm at impact. The striking edge should have a radius of 1.6 ± 0.1 mm. The striker and test piece clamp should have a clearance of 6.4 ± 0.3 mm at and immediately following impact. These dimensional requirements are illustrated in Figure 1. The velocity should be checked to make sure that if the voltage is changed by 6 % the required velocity is nevertheless obtained.

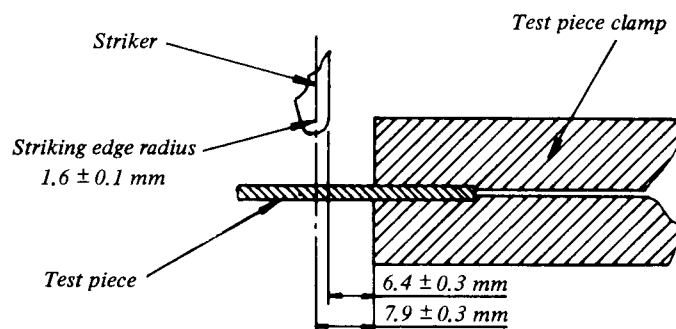

FIG. 1 — Test piece clamp and striker

- 2.2 *Temperature measuring device.* A thermocouple or a thermometer may be used. Copper-constantan thermocouples, used in conjunction with a potentiometer, are highly satisfactory. The thermometer should be calibrated in degrees Celsius divisions and should have a range suitable for the temperatures at which determinations are to be made. The temperature measuring device should be located as near the test pieces as possible.
- 2.3 *Heat-transfer medium.* The heat-transfer medium may be either liquid or gaseous. Any medium which remains fluid at the test temperature and which will not appreciably affect the materials being tested may be used. Among the liquids that have been found suitable for use at low temperatures are acetone, methyl alcohol, ethyl alcohol, butyl alcohol, silicone fluid and normal hexane. For temperatures down to -120°C , methylcyclohexane and liquid nitrogen have been found to be satisfactory with the use of modified apparatus.
- 2.4 *Temperature control.* Suitable means should be provided for controlling the temperature of the heat-transfer medium within ± 1 deg C if the medium is gaseous or within ± 0.5 deg C if liquid.
- Automatic regulation of temperature for a liquid medium may be obtained by means of a system consisting of an externally cooled tank connected to the test area with suitable tubing, a thermo-regulator, a pump, an electric immersion heater, and mercury switches. The regulator, alternately actuating both the pump and heater through the mercury switches, controls the amount of liquid coolant being pumped to the test area as well as the amount of heat coming from the heater.
- Manual temperature control for liquid media may be accomplished with powdered dry ice (solid carbon dioxide) and an electric immersion heater.
- 2.5 *Tank or test chamber.* A tank for liquid heat-transfer media or a test chamber for gaseous media should be provided.
- 2.6 *Stirrer or fan.* A stirrer for liquids, or a fan or blower for gaseous media, should be provided to ensure thorough circulation of the heat-transfer medium.

3. TEST PIECE

The test piece should be either

- type A : 40 ± 6 mm long, 6 ± 1 mm wide and 2.0 ± 0.2 mm thick, or
- type B : a modified T-50 test piece with dimensions as illustrated in Figure 2.

A minimum of 6.0 mm of the length (the tab end for type B test pieces) is held in the clamp. For any one test either four of type A or ten of type B test pieces should be used.

NOTE. – To prevent overloading of the test equipment it is important not to exceed, in any one test, the number of test pieces specified above.

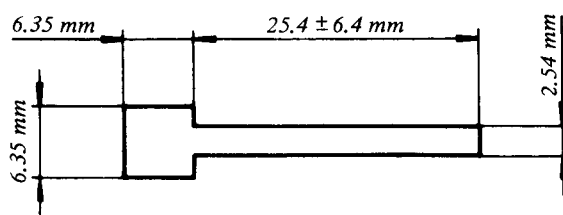

FIG. 2 – Modified T-50 test piece
Test piece thickness : 2.0 ± 0.2 mm

4. PROCEDURE

4.1 Test with liquid heat-transfer medium

4.1.1 Before a test is run, the bath should be prepared and the liquid brought to the starting temperature to be used. Sufficient liquid should be placed in the tank to ensure approximately 25 mm of liquid covering the test pieces.

4.1.2 The test pieces should be mounted in the apparatus and immersed for 3.0 ± 0.5 minutes at the test temperature.

For type A test pieces, four test pieces should be used per impact and for type B test pieces, ten test pieces should be used per impact.

NOTE. – Proper tightening of the clamp is of the utmost importance.

The clamp should be tightened so that each test piece is held with approximately the same pressure.

4.1.3 After immersion for the specified time at the test temperature, the temperature should be recorded and a single impact blow should be delivered to the test pieces.

4.1.4 Each test piece should be examined to determine whether or not it has failed. Failure is defined as any crack, fissure, or hole visible to the naked eye, or complete separation into two or more pieces. Where a test piece has not completely separated, it should be bent to an angle of 90° in the same direction as the bend caused by the impact. It should then be examined for cracks at the bend.

4.1.5 New test pieces should be used for each impact.

4.1.6 In establishing the lowest temperature of non-failure of a material, it is recommended that the test be started at a temperature below the expected lowest temperature of non-failure and test pieces be tested at intervals of 10 deg C, one set at each temperature, until no failure is obtained. The bath temperature should then be decreased to the highest value at which a failure has been observed and tests made at successively increasing temperatures. Steps of 2 deg C are recommended. Tests should then be made at each temperature until no failure at one temperature is observed. This temperature should be recorded as the temperature limit of brittleness.

4.2 Test with gaseous heat-transfer medium

4.2.1 Before a test is run, the refrigerating unit should be adjusted, and the test chamber, test apparatus and test pieces brought to thermal equilibrium at the desired temperature.*

4.2.2 The test chamber should be opened and the test pieces tested in accordance with the procedure described in clauses 4.1.2 to 4.1.6, except that the test pieces should remain at the test temperature for 1 hour prior to being impacted. Conditioning periods longer than 1 hour may be used for studying crystallization and plasticizer-time effects.

* The apparatus may be used in a gaseous medium if it can be shown that low temperatures will not affect the operation of the solenoid-actuated impact mechanism.

An alternative method is to remove the test chamber and to place the striker and test piece clamp through the top of the refrigerating unit with the solenoid remaining outside the unit and insulated from the cold air.

5. TEST REPORT

The test report should include the following :

- (a) the temperature limit of brittleness, defined as the lowest temperature of non-failure of the appropriate number of test pieces tested under the specified conditions; failure is defined as any crack, fissure, or hole visible to the naked eye, or complete separation into two or more pieces;
- (b) complete identification of the material tested, including type, source, manufacturer's code designation, form and previous history;
- (c) thickness and type of test piece;
- (d) heat-transfer medium used;
- (e) conditioning time and procedure followed.

iTeh STANDARD PREVIEW
(standards.iteh.ai)

ISO/R 812:1968

<https://standards.iteh.ai/catalog/standards/sist/90239a05-d9be-487f-87bd-2f9db97020eb/iso-r-812-1968>

ANNEX

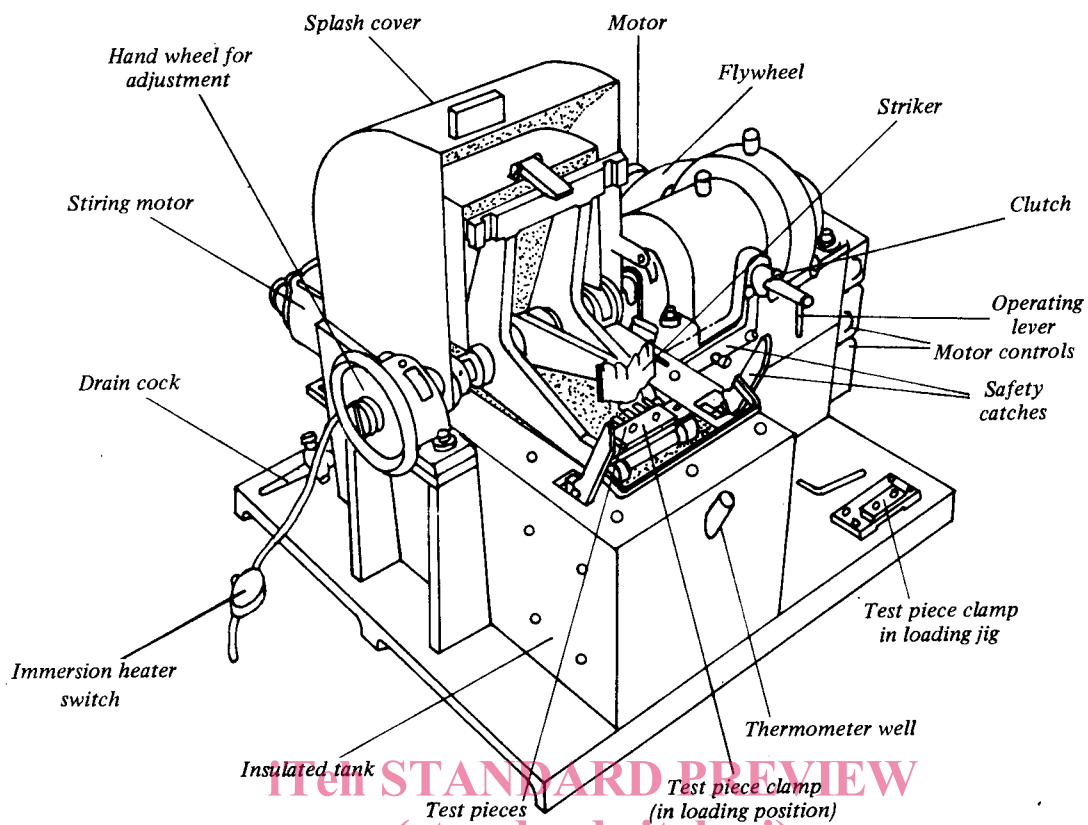

FIG. 3 - Motor-driven brittleness temperature tester

ISO/R 812:1968

<https://standards.iteh.ai/catalog/standards/sist/90239c05-d9be-487f-87bd-2f9db91271b0/iso-812-1968>

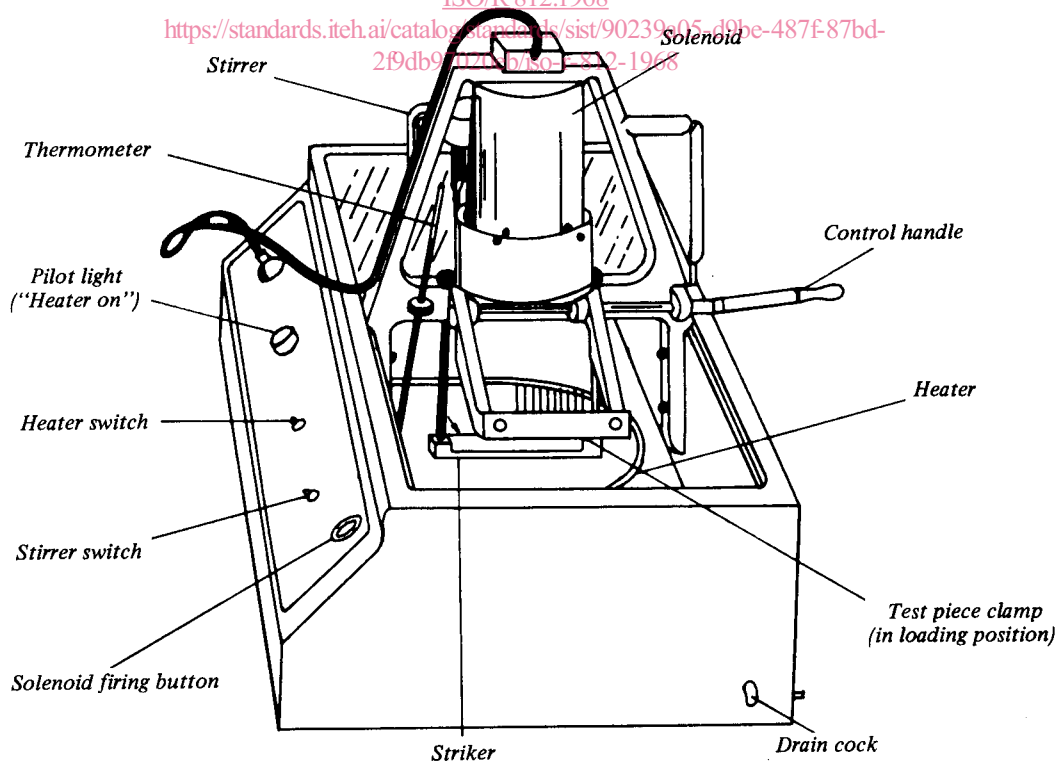

FIG. 4 - Solenoid-actuated brittleness temperature tester