



# SLOVENSKI STANDARD

## SIST EN 847-2:2002

01-januar-2002

---

### Tools for woodworking - Safety requirements - Part 2: Requirements for the shank of shank mounted milling tools

Tools for woodworking - Safety requirements - Part 2: Requirements for the shank of shank mounted milling tools

Maschinen-Werkzeuge für Holzbearbeitung - Sicherheitstechnische Anforderungen - Teil 2: Anforderungen für den Schaft von Fräswerkzeugen

Outils pour le travail du bois - Prescriptions de sécurité - Partie 2 : Prescriptions pour les queues des fraises a queue

[SIST EN 847-2:2002](https://standards.iteh.ai/catalog/standards/sist/873dbf5c-9482-466a-9b13-82651ce738c4/sist-en-847-2-2002)

[https://standards.iteh.ai/catalog/standards/sist/873dbf5c-9482-466a-9b13-](https://standards.iteh.ai/catalog/standards/sist/873dbf5c-9482-466a-9b13-82651ce738c4/sist-en-847-2-2002)

[82651ce738c4/sist-en-847-2-2002](https://standards.iteh.ai/catalog/standards/sist/873dbf5c-9482-466a-9b13-82651ce738c4/sist-en-847-2-2002)

**Ta slovenski standard je istoveten z: EN 847-2:2001**

---

#### **ICS:**

25.100.20	Orodja za frezanje	Milling tools
79.120.20	Lesnoobdelovalno orodje	Woodworking tools

**SIST EN 847-2:2002**

**en**

**iTeh STANDARD PREVIEW**  
**(standards.iteh.ai)**

SIST EN 847-2:2002

<https://standards.iteh.ai/catalog/standards/sist/873dbf5c-9482-466a-9b13-82651ce738c4/sist-en-847-2-2002>

EUROPEAN STANDARD

EN 847-2

NORME EUROPÉENNE

EUROPÄISCHE NORM

March 2001

ICS 79.120.10

English version

## Tools for woodworking - Safety requirements - Part 2: Requirements for the shank of shank mounted milling tools

Outils pour le travail du bois - Prescriptions de sécurité -  
Partie 2 : Prescriptions pour les queues des fraises à  
queue

Maschinen-Werkzeuge für Holzbearbeitung -  
Sicherheitstechnische Anforderungen - Teil 2:  
Anforderungen für den Schaft von Fräswerkzeugen

This European Standard was approved by CEN on 18 January 2001.

CEN members are bound to comply with the CEN/CENELEC Internal Regulations which stipulate the conditions for giving this European Standard the status of a national standard without any alteration. Up-to-date lists and bibliographical references concerning such national standards may be obtained on application to the Management Centre or to any CEN member.

This European Standard exists in three official versions (English, French, German). A version in any other language made by translation under the responsibility of a CEN member into its own language and notified to the Management Centre has the same status as the official versions.

CEN members are the national standards bodies of Austria, Belgium, Czech Republic, Denmark, Finland, France, Germany, Greece, Iceland, Ireland, Italy, Luxembourg, Netherlands, Norway, Portugal, Spain, Sweden, Switzerland and United Kingdom.

[SIST EN 847-2:2002](https://standards.iteh.ai/catalog/standards/sist/873dbf5c-9482-466a-9b13-82651ce738c4/sist-en-847-2-2002)

<https://standards.iteh.ai/catalog/standards/sist/873dbf5c-9482-466a-9b13-82651ce738c4/sist-en-847-2-2002>



EUROPEAN COMMITTEE FOR STANDARDIZATION  
COMITÉ EUROPÉEN DE NORMALISATION  
EUROPÄISCHES KOMITEE FÜR NORMUNG

Management Centre: rue de Stassart, 36 B-1050 Brussels

**iTeh STANDARD PREVIEW**  
**(standards.iteh.ai)**

[SIST EN 847-2:2002](#)

<https://standards.iteh.ai/catalog/standards/sist/873dbf5c-9482-466a-9b13-82651ce738c4/sist-en-847-2-2002>

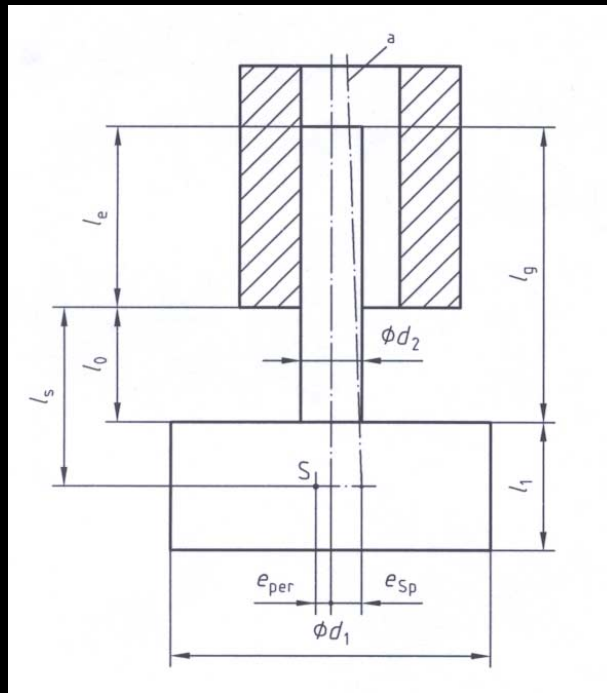

**iTeh STANDARD PREVIEW**  
**(standards.iteh.ai)**

SIST EN 847-2:2002

<https://standards.iteh.ai/catalog/standards/sist/873dbf5c-9482-466a-9b13-82651ce738c4/sist-en-847-2-2002>

**iTeh STANDARD PREVIEW**  
**(standards.iteh.ai)**

[SIST EN 847-2:2002](#)

<https://standards.iteh.ai/catalog/standards/sist/873dbf5c-9482-466a-9b13-82651ce738c4/sist-en-847-2-2002>

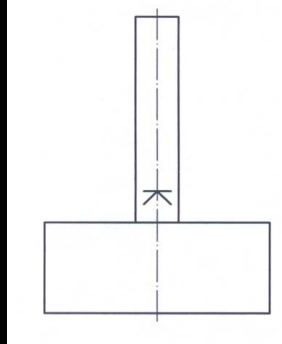

**iTeh STANDARD PREVIEW**  
**(standards.iteh.ai)**

SIST EN 847-2:2002

<https://standards.iteh.ai/catalog/standards/sist/873dbf5c-9482-466a-9b13-82651ce738c4/sist-en-847-2-2002>

**iTeh STANDARD PREVIEW**  
**(standards.iteh.ai)**

[SIST EN 847-2:2002](#)

<https://standards.iteh.ai/catalog/standards/sist/873dbf5c-9482-466a-9b13-82651ce738c4/sist-en-847-2-2002>



