

INTERNATIONAL STANDARD

ISO
812

First edition
1991-11-15

Rubber, vulcanized — Determination of low-temperature brittleness

iTeh STANDARD PREVIEW
*Caoutchouc vulcanisé — Détermination de la fragilité à basse
température*
(standards.iteh.ai)

ISO 812:1991

<https://standards.iteh.ai/catalog/standards/sist/1b2be3fb-634b-49d9-8705-96588c87acf7/iso-812-1991>



Reference number
ISO 812:1991(E)

Foreword

ISO (the International Organization for Standardization) is a worldwide federation of national standards bodies (ISO member bodies). The work of preparing International Standards is normally carried out through ISO technical committees. Each member body interested in a subject for which a technical committee has been established has the right to be represented on that committee. International organizations, governmental and non-governmental, in liaison with ISO, also take part in the work. ISO collaborates closely with the International Electrotechnical Commission (IEC) on all matters of electrotechnical standardization.

Draft International Standards adopted by the technical committees are circulated to the member bodies for voting. Publication as an International Standard requires approval by at least 75 % of the member bodies casting a vote.

International Standard ISO 812 was prepared by Technical Committee ISO/TC 45, *Rubber and rubber products*, Sub-Committee SC 2, *Physical and degradation tests*.

<https://standards.iteh.ai/catalog/standards/sist/1b2be3fb-634b-49d9-8705-998121968>

The first edition cancels and replaces ISO/R 812:1968, of which it constitutes a technical revision.

Annex A of this International Standard is for information only.

© ISO 1991

All rights reserved. No part of this publication may be reproduced or utilized in any form or by any means, electronic or mechanical, including photocopying and microfilm, without permission in writing from the publisher.

International Organization for Standardization
Case Postale 56 • CH-1211 Genève 20 • Switzerland

Printed in Switzerland

Rubber, vulcanized — Determination of low-temperature brittleness

1 Scope

1.1 This International Standard specifies a method for determining the lowest temperature at which rubber materials do not exhibit brittle failure when impacted under specified conditions.

Brittleness temperatures thus determined do not necessarily relate to the lowest temperatures at which the material may be used, since brittleness will be modified by the conditions of contact and especially by the rate of impact. Data obtained by this method should therefore be used to predict the behaviour of rubbers at low temperatures only in applications in which the conditions of deformation are similar to those specified in the test.

1.2 Two procedures are described: procedure A, in which the brittleness temperature is determined, and procedure B, in which the test piece is impacted at a specified temperature.

The latter procedure is used in the classification of rubber materials and for specification purposes.

NOTE 1 A similar test for rubber-coated fabrics is described in ISO 4646:1989, *Rubber- or plastics-coated fabrics — Low-temperature impact test*.

2 Normative references

The following standards contain provisions which, through reference in this text, constitute provisions of this International Standard. At the time of publication, the editions indicated were valid. All stan-

dards are subject to revision, and parties to agreements based on this International Standard are encouraged to investigate the possibility of applying the most recent editions of the standards indicated below. Members of IEC and ISO maintain registers of currently valid International Standards.

ISO 471:1983, *Rubber — Standard temperatures, humidities and times for the conditioning and testing of test pieces*.

ISO 4826:1981, *Rubber, vulcanized — Time-interval between vulcanization and testing — Specification*.

ISO 3383:1985, *Rubber — General directions for achieving elevated or subnormal temperatures for test purposes*.

ISO 4661-1:1986, *Rubber, vulcanized — Preparation of samples and test pieces — Part 1: Physical tests*.

3 Definitions

For the purposes of this International Standard, the following definitions apply.

3.1 brittleness temperature: The lowest temperature of non-failure, due to low-temperature embrittlement, of the appropriate number of test pieces tested under the specified conditions.

3.2 testing speed: The relative linear velocity at impact between the striking edge of the test apparatus and a clamped test piece.

4 Apparatus and materials

A number of different impact testers are available commercially.¹⁾ The apparatus used shall meet the requirements specified below for certain of the components.

4.1 Test piece clamp and striking arm (see figure 1).

4.1.1 The test piece clamp shall be rigid and designed to hold the test piece(s) as cantilever beam(s). Each individual test piece shall be held firmly and securely in the clamp without distortion.

4.1.2 The striking edge shall move relative to the test piece(s) along a path normal to the upper surface of the test piece(s) at a linear testing speed of $2,0 \text{ m/s} \pm 0,2 \text{ m/s}$ at impact. The speed shall be maintained within this range for at least 6 mm of travel following the impact.

In order to obtain a speed within the specified limits during and after impact, care shall be taken to ensure that the striking energy is sufficient. It has been found that a striking energy of at least 3,0 J per test piece is necessary. It may therefore be necessary to limit the number of test pieces impacted at one time.

NOTE 2 Commercial apparatus is available meeting the requirements of this International Standard in which the striking edge is driven by a motor, by a solenoid, by gravity or by a spring. A method for the speed calibration of a solenoid-actuated-type low-temperature impact tester is given in annex A.

4.1.3 The principal dimensions of the apparatus shall be as follows:

- the striking edge shall have a radius of $1,6 \text{ mm} \pm 0,1 \text{ mm}$;
- the clearance between the striking arm and the test piece clamp at impact shall be $6,4 \text{ mm} \pm 0,3 \text{ mm}$;
- the separation between the point of impact of the striking edge and the test piece clamp shall be $8 \text{ mm} \pm 0,3 \text{ mm}$;

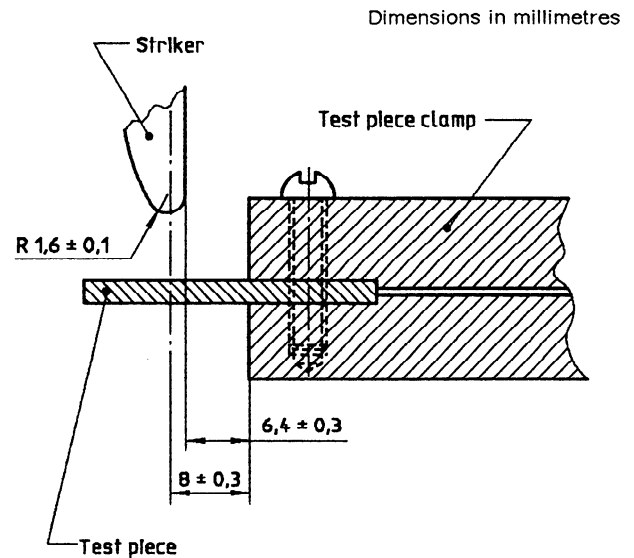

Figure 1 — Test piece clamp and striking arm

4.2 Temperature indicator, used with a thermocouple or other temperature sensing device, capable of covering the range being tested and accurate to within $\pm 0,5 \text{ }^\circ\text{C}$.

A thermocouple constructed of copper and constantan wires of diameter 0,2 mm to 0,5 mm, welded at their junction, has been found highly satisfactory.

The thermocouple junction or thermometer bulb shall be placed as near to the test pieces as possible.

4.3 Heat-transfer medium, liquid or gaseous, which remains fluid at the test temperature and which does not appreciably affect the material being tested.

The medium shall be maintained at the test temperature to within $\pm 0,5 \text{ }^\circ\text{C}$ (see ISO 3383).

1) Any impact tester may be used which is found to be suitable for performing the test. Impact testers which have been reported as suitable are obtainable in the UK from H.W. Wallace, 172 St. James's Road, Croydon CR9 2HR, and in the USA from Testing Machines Inc., 400 Bayview Avenue, Amityville L.I., NY 11701 and from Precision Scientific Co., 3737 W.Cortland St., Chicago, IL 60647.

This information is given for the convenience of users of this International Standard and does not constitute an endorsement by ISO of any of the products named.

NOTE 3 The following fluids can be used:

- for temperatures down to $-60\text{ }^{\circ}\text{C}$, silicone fluids of kinematic viscosity $5\text{ mm}^2/\text{s}$ at ambient temperature, owing to their chemical inertness towards rubbers, their non-flammability and their non-toxicity;
- for temperatures down to $-70\text{ }^{\circ}\text{C}$, methanol or ethanol;
- for temperatures down to $-120\text{ }^{\circ}\text{C}$, methylcyclohexane cooled by liquid nitrogen (found to be satisfactory with the use of suitable apparatus).

5 Test pieces

Test pieces shall be prepared in accordance with ISO 4661-1. They shall normally be punched from sheet using a suitable sharp die, and shall be either

type A: a strip 25 mm to 40 mm long, 6 mm \pm 1 mm wide and 2,0 mm \pm 0,2 mm thick,

OR

type B: a test piece 2,0 mm \pm 0,2 mm thick and of the shape and dimensions given in figure 2.

Alternatively, type A test pieces may be prepared using sharp, parallel double-bladed cutters, in a single stroke. The strip so formed is then cut to the correct length.

It is essential to use sharp cutters in the preparation of test pieces if reliable results are to be obtained.

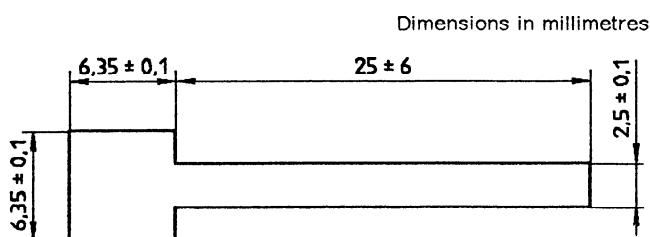

Figure 2 — Type B test piece

6 Time interval between manufacture and testing

Unless otherwise specified, the time interval between vulcanization and testing shall be in accordance with ISO 1826.

7 Procedure

7.1 Procedure A

7.1.1 Test with liquid heat-transfer medium

7.1.1.1 Before running a test, prepare a bath of the liquid and bring it to the starting temperature to be used. Place sufficient liquid in the bath to ensure approximately 25 mm of liquid covering the test piece(s).

7.1.1.2 Mount the test piece(s) in the apparatus and immerse for 5 min at the test temperature (see ISO 3383).

The free length of the test piece(s) shall be greater than 19 mm.

Use four type A test pieces per impact or ten type B test pieces, if the available striking energy has the minimum value specified in 4.1.2.

Proper tightening of the clamp is of the utmost importance. The clamp shall be tightened so that each test piece is held with approximately the same pressure.

7.1.1.3 After immersion for the specified time at the test temperature, record the temperature and deliver a single impact blow to the test piece(s).

7.1.1.4 Examine each test piece to determine whether or not it has failed. Failure is defined as any crack, fissure or hole visible to the naked eye, or complete separation into two or more pieces. Where a test piece has not completely separated, bend it to an angle of 90° in the same direction as the bend caused by the impact. Then examine it for cracks at the bend.

7.1.1.5 Use new test pieces for each impact.

7.1.1.6 In establishing the lowest temperature of non-failure of a material, it is recommended that the test be started at a temperature below the expected lowest temperature of non-failure and test pieces be tested at intervals of $10\text{ }^{\circ}\text{C}$, one set at each temperature, until no failure is obtained. Then decrease the bath temperature to the highest value at which a failure has been observed and make tests at successively increasing temperatures. Steps of $2\text{ }^{\circ}\text{C}$ are recommended. Make tests at each temperature until no failure at one temperature is observed. Record this temperature as the temperature limit of brittleness.

7.1.2 Test with gaseous heat-transfer medium

7.1.2.1 Before running a test, adjust the refrigerating unit and bring the test chamber, test apparatus and test pieces to thermal equilibrium at the desired temperature²⁾ (see ISO 3383).

7.1.2.2 Open the test chamber and test the test pieces in accordance with the procedure specified in 7.1.1.2 to 7.1.1.6, except that the test pieces shall remain at the test temperature for 10 min prior to being impacted. Conditioning periods longer than 1 h may be used for studying crystallization and time-dependent effects of plasticizers.

7.2 Procedure B

7.2.1 Bring the test piece(s) to equilibrium at the test temperature specified in the material specification or classification (see ISO 3383). Actuate the test apparatus to deliver a single impact to the test piece(s).

7.2.2 Remove the test piece(s) from the test chamber and allow to reach a standard temperature (see ISO 471). Examine the test piece(s) to determine whether or not failure has occurred as defined in 7.1.1.4.

7.2.3 Test at least four type A or ten type B test pieces. It is permissible to impact all four type A or ten type B at the same time provided that the speed at impact and after impact is within the apparatus requirements given in 4.1.2.

7.2.4 Report the material as satisfactory if no failure is observed in any one of the set of test pieces, or unsatisfactory should any failure be observed.

8 Test report

The test report shall include the following information:

- a) a reference to this International Standard;
- b) all details necessary for the complete identification of the material tested;
- c) the type of test piece used;
- d) the number of test pieces used, and the number impacted at each impact;
- e) the heat-transfer medium and type of test equipment used;
- f) whether procedure A or B was used;
- g) the temperature(s) of test;
- h) the brittleness temperature in the case of procedure A;
- i) whether or not the material was satisfactory in the case of procedure B.

2) A solenoid-actuated apparatus may be used in a gaseous medium if it can be shown that low temperatures will not affect the operation of the solenoid-actuated impact mechanism.

An alternative method with a solenoid-actuated apparatus is to remove the test chamber and to insert the striker and test piece clamp through the top of the refrigerating unit with the solenoid remaining outside the unit and insulated from the cold air.

Annex A (informative)

Speed calibration of a solenoid-actuated low-temperature impact tester³⁾

A.1 Speed calibration prior to testing

A.1.1 Principle

The height, h , to which a steel ball, suspended on the striker mechanism of the tester, rises after the striker has had its upward motion halted by contact with a mechanical stop is measured. The ball decelerates in such a manner that the law governing a body moving freely under the influence of gravity applies.

A.1.2 Procedure

A.1.2.1 Securing ball support

Remove either one of the nuts that fasten the striking bar guide rods to the solenoid armature yoke. Place the small hole in the ball support (see figure A.1) over the guide rod and replace and secure the nut.

A.1.2.2 Adjusting stroke or striker

Remove the metal guard from around the solenoid. Spread open the rubber bumper (see figure A.2) and insert it around the armature. Replace the solenoid guard. Insert a typical test piece into the specimen holder of the tester. Raise the striking mechanism by hand until the end of the stroke is reached. It is essential that, with the striking mechanism raised to its maximum height, the striker bar of the tester is in contact with the test piece but that the bar is not in the plane of the test piece. If the striker bar is not in contact with the test piece, the rubber bumper shall be removed and replaced by a thinner bumper. Conversely, if the striker bar moves into the plane of the test piece, the bumper shall be replaced by a thicker one.

A.1.2.3 Placement of ball and measuring tube

Place a 19 mm diameter steel ball on the ball holder. (In theory, the upward flight of the ball is independent of the mass of the ball. However, if the mass is too large, the motion of the striker bar may be impeded.) Clamp a glass or clear plastics tube with a minimum inside diameter of 25,4 mm in a

vertical position directly over the ball. The tube should contain a scale divided into 5 mm intervals. The zero position on the scale should be aligned with the top of the ball when the ball is at the top of the stroke of the striker mechanism.

A.1.2.4 Measurement and calculation

With the tester equipped as described above and devoid of test pieces and immersion medium, actuate the solenoid and read the ball height to the nearest 5 mm. Make at least five measurements. Average all results and convert the average to metres. Determine the striker speed, v , in metres per second, from the following equation:

$$v = \sqrt{2gh}$$

where

g

is the acceleration due to gravity, in metres per second squared ($= 9,8 \text{ m/s}^2$);

h

is the average ball height, in metres.

NOTE 4 Calibration measurements should be made with the tester supported on a non-resilient surface, such as a laboratory bench or concrete floor. Resilient mountings tend to absorb some of the striker energy causing low ball height values.

A.2 Speed calibration during testing

A.2.1 With the tester equipped with ball support, ball and measuring tube (see A.1), but without the rubber bumper (tested in normal operating condition) and devoid of test pieces and immersion medium, actuate the solenoid and read the ball height to the nearest 5 mm. Make ten measurements. From the lowest and highest ball height readings, determine the range in striker speed, using the equation in A.1.2.4. This range is termed "range of speed at the top of the stroke".

A.2.2 With the tester equipped as described in A.2.1, but also with test piece(s) and immersion medium, conduct the brittleness test as described in clause 7. Read the ball height each time the solenoid is actuated. Convert the ball height to speed as shown in A.1.2.4. If the speed lies within

3) Users should note that this annex applies only to certain types of impact tester.

the predetermined range of speed at the top of the stroke, the test should be considered valid. If the speed lies outside of the predetermined range, the test is invalid and should not be reported. Should successive tests be invalid, adjustments should be made to bring the speed at the top of the stroke within the acceptable, predetermined range. This may be accomplished by reducing the number of test pieces tested per impact.

A.2.3 The following example typifies the entire speed calibration procedure for solenoid-actuated testers.

- a) Using the procedure specified in A.1, the striker speed at the point of impact of a tester devoid of test pieces and immersion medium was found to be 1,9 m/s. This speed is within the specified limits of 4.1.2.
- b) Using the procedure in A.2.1, with the tester devoid of test pieces and immersion medium, the range of striker speeds at the top of the stroke was found to be 2,5 m/s to 2,7 m/s. This range becomes the acceptable range for this series of

tests. The acceptable range should be established each time the striker speed at the point of impact is determined (see A.1).

- c) Using the procedure of A.2.2, with the tester containing a test piece(s) and immersion medium, the speed at the top of the stroke during the first solenoid actuation was found to be 2,5 m/s. The speed is within the acceptable range and the test is valid.
- d) The speeds at the top of the stroke during the second and third solenoid actuations were found to be 2,4 m/s and 2,3 m/s respectively. These speeds are outside the acceptable range and both tests are invalid.
- e) Adjustments were made to increase the speed at the top of the stroke, using the procedures given in A.2.2.
- f) The speeds at the top of the stroke during the fourth and all subsequent solenoid actuations were found to lie between 2,5 m/s and 2,7 m/s. The results of all these tests are valid.

iTeh STANDARD PREVIEW
(standards.iteh.ai)

Dimensions in millimetres

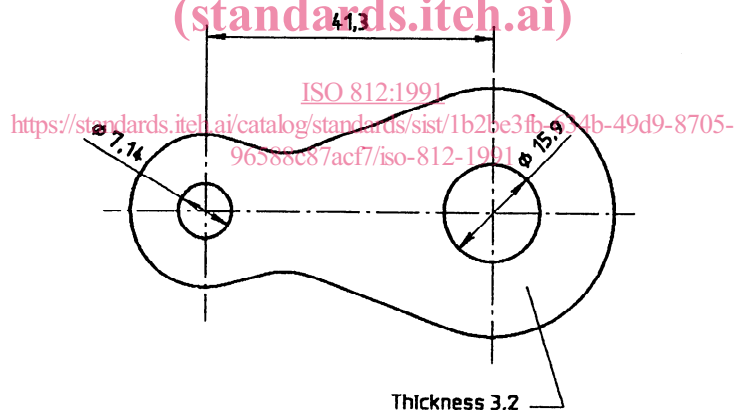

Figure A.1 — Ball support

Dimensions in millimetres

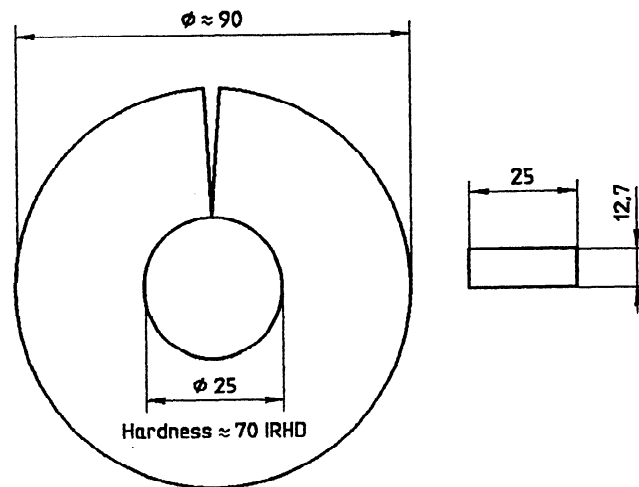

Figure A.2 — Rubber bumper

iTeh STANDARD PREVIEW
(standards.iteh.ai)

ISO 812:1991

<https://standards.iteh.ai/catalog/standards/sist/1b2be3fb-634b-49d9-8705-96588c87acf7/iso-812-1991>