**Thermal insulating products for building
equipment and industrial installations —
Determination of water vapour
transmission properties of preformed
pipe insulation**

*Produits isolants thermiques pour les équipements des bâtiments et les
installations industrielles — Détermination des propriétés de
transmission de la vapeur d'eau des coquilles isolantes préformées*

iTeh STANDARD PREVIEW
(standards.iteh.ai)

ISO 12629:2011

<https://standards.iteh.ai/catalog/standards/sist/5af57eef-6366-49d4-a35e-f3134d276dd9/iso-12629-2011>



PDF disclaimer

This PDF file may contain embedded typefaces. In accordance with Adobe's licensing policy, this file may be printed or viewed but shall not be edited unless the typefaces which are embedded are licensed to and installed on the computer performing the editing. In downloading this file, parties accept therein the responsibility of not infringing Adobe's licensing policy. The ISO Central Secretariat accepts no liability in this area.

Adobe is a trademark of Adobe Systems Incorporated.

Details of the software products used to create this PDF file can be found in the General Info relative to the file; the PDF-creation parameters were optimized for printing. Every care has been taken to ensure that the file is suitable for use by ISO member bodies. In the unlikely event that a problem relating to it is found, please inform the Central Secretariat at the address given below.

iTeh STANDARD PREVIEW
(standards.iteh.ai)

ISO 12629:2011

<https://standards.iteh.ai/catalog/standards/sist/5af57eef-6366-49d4-a35e-f3134d276dd9/iso-12629-2011>



COPYRIGHT PROTECTED DOCUMENT

© ISO 2011

All rights reserved. Unless otherwise specified, no part of this publication may be reproduced or utilized in any form or by any means, electronic or mechanical, including photocopying and microfilm, without permission in writing from either ISO at the address below or ISO's member body in the country of the requester.

ISO copyright office
Case postale 56 • CH-1211 Geneva 20
Tel. + 41 22 749 01 11
Fax + 41 22 749 09 47
E-mail copyright@iso.org
Web www.iso.org

Published in Switzerland

Contents

Page

Foreword	iv
1 Scope	1
2 Normative references	1
3 Terms and definitions	2
4 Principle	2
5 Apparatus	3
6 Test specimens	3
6.1 General	3
6.2 Dimensions of the test specimen	3
6.3 Number of test specimens	3
6.4 Conditioning of test specimens	4
7 Procedure	4
8 Calculation and expression of results	5
8.1 Water vapour flow rate	5
8.2 Water vapour transmission rate	6
8.3 Water vapour permeance	6
8.4 Water vapour resistance	6
8.5 Water vapour permeability	6
8.6 Water vapour diffusion resistance factor	7
9 Accuracy of measurement	9
10 Test report	9
Annex A (informative) Correction for air pressure variations during testing	11
Bibliography	12

Foreword

ISO (the International Organization for Standardization) is a worldwide federation of national standards bodies (ISO member bodies). The work of preparing International Standards is normally carried out through ISO technical committees. Each member body interested in a subject for which a technical committee has been established has the right to be represented on that committee. International organizations, governmental and non-governmental, in liaison with ISO, also take part in the work. ISO collaborates closely with the International Electrotechnical Commission (IEC) on all matters of electrotechnical standardization.

International Standards are drafted in accordance with the rules given in the ISO/IEC Directives, Part 2.

The main task of technical committees is to prepare International Standards. Draft International Standards adopted by the technical committees are circulated to the member bodies for voting. Publication as an International Standard requires approval by at least 75 % of the member bodies casting a vote.

Attention is drawn to the possibility that some of the elements of this document may be the subject of patent rights. ISO shall not be held responsible for identifying any or all such patent rights.

ISO 12629 was prepared by Technical Committee ISO/TC 163, *Thermal performance and energy use in the built environment*, Subcommittee SC 1, *Test and measurement methods*.

ISO 12629 includes the original EN 13469 prepared by Technical Committee CEN/TC 88 *Thermal insulating materials and products*. However,

iTeh STANDARD PREVIEW
(standards.iteh.ai)

- Subclause 6.4, “conditioning of test specimen”, [ISO 12629:2011](#)
- Clause 10, “test report” <https://standards.iteh.ai/catalog/standards/sist/5af57eef-6366-49d4-a35e-b3134d276dd9/iso-12629-2011>

have been modified to reflect conditions for tropical countries.

This International Standard is one of a series of standards which specify test methods for determining dimensions and properties of thermal insulating materials and products. The original EN 13469 supports a series of product standards for thermal insulating materials and products which derive from the Council Directive of 21 December 1988 on the approximation of laws, regulations and administrative provisions of the Member States relating to constructive products (Directive 89/106/EEC) through the consideration of the essential requirements.

This International Standard is one of a series of existing European Standards on test methods for products used to insulate building equipment and industrial installations which is comprised of the following group of International Standards:

ISO standard	Title	Respective EN standard
ISO 12623	<i>Thermal insulating products for building equipment and industrial installations — Determination of short-term water absorption by partial immersion of preformed pipe insulation</i>	EN 13472
ISO 12624	<i>Thermal insulation products — Determination of trace quantities of water soluble chloride, fluoride, silicate, sodium ions and pH</i>	EN 13468
ISO 12628	<i>Thermal insulating products for building equipment and industrial installations — Determination of dimensions, squareness and linearity of preformed pipe insulation</i>	EN 13467
ISO 12629	<i>Thermal insulating products for building equipment and industrial installations — Determination of water vapour transmission properties of preformed pipe insulation</i>	EN 13469

A further series of existing European Standards on test methods was adopted by ISO. This “package” of standards comprises the following group of interrelated standards:

ISO	Title	Respective EN standard
ISO 29465	<i>Thermal insulating products for building applications — Determination of length and width</i>	EN 822
ISO 29466	<i>Thermal insulating products for building applications — Determination of thickness</i>	EN 823
ISO 29467	<i>Thermal insulating products for building applications — Determination of squareness</i>	EN 824
ISO 29468	<i>Thermal insulating products for building applications — Determination of flatness</i>	EN 825
ISO 29469	<i>Thermal insulating products for building applications — Determination of compression behaviour</i>	EN 826
ISO 29470	<i>Thermal insulating products for building applications — Determination of the apparent density</i>	EN 1602
ISO 29471	<i>Thermal insulating products for building applications — Determination of dimensional stability under constant normal laboratory conditions (23 degrees C/50 % relative humidity)</i>	EN 1603
ISO 29472	<i>Thermal insulating products for building applications — Determination of dimensional stability under specified temperature and humidity conditions</i>	EN 1604
ISO 29764	<i>Thermal insulating products for building applications — Determination of deformation under specified compressive load and temperature conditions</i>	EN 1605
ISO 29765	<i>Thermal insulating products for building applications — Determination of tensile strength perpendicular to faces</i>	EN 1607
ISO 29766	<i>Thermal insulating products for building applications — Determination of tensile strength parallel to faces</i>	EN 1608
ISO 29767	<i>Thermal insulating products for building applications — Determination of short-term water absorption by partial immersion</i>	EN 1609

ISO 12629:2011(E)

ISO	Title	Respective EN standard
ISO 29768	<i>Thermal insulating products for building applications — Determination of linear dimensions of test specimens</i>	EN 12085
ISO 29769	<i>Thermal insulating products for building applications — Determination of behaviour under point load</i>	EN 12430
ISO 29770	<i>Thermal insulating products for building applications — Determination of thickness for floating-floor insulating products</i>	EN 12431
ISO 29771	<i>Thermal insulating materials for building applications — Determination of organic content</i>	EN 13820
ISO 29803	<i>Thermal insulation products for building applications — Determination of the resistance to impact of external thermal insulation composite systems (ETICS)</i>	EN 13497
ISO 29804	<i>Thermal insulation products for building applications — Determination of the tensile bond strength of the adhesive and of the base coat to the thermal insulation material</i>	EN 13494
ISO 29805	<i>Thermal insulation products for building applications — Determination of the mechanical properties of glass fibre meshes</i>	EN 13496

The Application of Agreement on technical cooperation between ISO and CEN (Vienna Agreement), Modes 1, 2, 4 and 5, was not approved by CEN/TC 88 and the necessity not seen by its stakeholders.

ITEH STANDARD PREVIEW
(standards.iteh.ai)

[ISO 12629:2011](https://standards.iteh.ai/catalog/standards/sist/5af57eef-6366-49d4-a35e-f3134d276dd9/iso-12629-2011)

<https://standards.iteh.ai/catalog/standards/sist/5af57eef-6366-49d4-a35e-f3134d276dd9/iso-12629-2011>

Thermal insulating products for building equipment and industrial installations — Determination of water vapour transmission properties of preformed pipe insulation

1 Scope

This International Standard specifies the equipment and procedure for determining the water vapour transmission properties in the steady state under specified test conditions for test specimens of preformed pipe insulation. It is applicable to thermal insulating products.

It is intended to be used for homogeneous materials (see Note below) and for products which may have integral skins or adhered facings of some different material.

NOTE A material is considered to be homogeneous in terms of mass distribution if its density is approximately the same throughout, i.e. if the measured density values are close to its mean density.

The water vapour transmission rate and permeance values are specific to the test specimen (i.e. the product) thickness tested. For homogeneous products, the water vapour permeability is a property of the material.

If the pipe insulation is cut from a flat product, then the water vapour transmission properties can be obtained from tests carried out on the flat product with similar properties in accordance with EN 12086.

<https://standards.iteh.ai/catalog/standards/sist/5af57eef-6366-49d4-a35e-b3134d276dd9/iso-12629-2011>

2 Normative references

The following referenced documents are indispensable for the application of this document. For dated references, only the edition cited applies. For undated references, the latest edition of the referenced document (including any amendments) applies.

ISO 12628, *Thermal insulating products for building equipment and industrial installations — Determination of dimensions, squareness and linearity of preformed pipe insulation*

ISO 29768, *Thermal insulating products for building applications — Determination of linear dimensions of test specimens*

EN 12086, *Thermal insulating products for building applications — Determination of water vapour transmission properties*

3 Terms and definitions

For the purposes of this document, the following terms and definitions apply.

- 3.1 water vapour flow rate**
G
quantity of water vapour transmitted through the surface of the test specimen in unit time
- 3.2 water vapour transmission rate**
g
quantity of water vapour transmitted through unit area in unit time under specified conditions of temperature, humidity and thickness
- 3.3 water vapour permeance**
W
quotient of water vapour transmission rate of the test specimen and the water vapour pressure difference between the test specimen faces during the test
- 3.4 water vapour resistance**
Z
inverse of water vapour permeance ($1/W$)
- 3.5 water vapour permeability**
δ
product of the permeance and the thickness of the test specimen ($δ = W \times d$)
- NOTE** The water vapour permeability of a homogeneous product is a property of the material. It is the quantity of water vapour transmitted per unit of time through a unit area of the product per unit of vapour pressure difference between its faces for a unit thickness.
- 3.6 water vapour diffusion resistance factor**
μ
quotient of the water vapour permeability of air and the water vapour permeability of the material or the homogeneous product concerned
- NOTE** It indicates the relative magnitude of the water vapour resistance of the product and that of an equally thick layer of stationary air at the same temperature.

4 Principle

A desiccant filled “dry-cup” made from a preformed pipe insulation test specimen is placed in a test atmosphere whose temperature and humidity are controlled. Because of the difference between the partial water vapour pressures in the test assembly and in the test atmosphere water vapour flows through the test specimen, periodic weighings of the assembly are made to determine the rate of water vapour transmission when the steady state is reached.

For products with a low water vapour transmission rate, special consideration has to be taken into account (see Annex A).

5 Apparatus

5.1 Chamber, capable of being maintained within a temperature of $(23 \pm 1) ^\circ\text{C}$ and an RH (relative humidity) of $(50 \pm 3) \%$.

NOTE In order to maintain the required conditions throughout the chamber, it can be necessary to use air circulation with an air speed between 0,02 m/s to 0,3 m/s.

5.2 Desiccant, anhydrous calcium chloride (CaCl_2) with particle size 2 mm to 15 mm (RH 0 %) or any other desiccant that gives the same results.

5.3 Analytical balance, capable of weighing the test assembly to an accuracy of ± 1 mg or better. If larger test assemblies are used, the weighing accuracy may be determined with respect to the total weight and the required accuracy of the test results.

5.4 Measuring instruments, capable of determining linear dimensions and thicknesses in accordance with the requirements of ISO 29768 or ISO 12628, whichever is relevant.

5.5 Aluminium foil, water vapour diffusion tight (at least 50 μm thick) protected with a polymer film on the face in contact with the calcium chloride (CaCl_2).

5.6 Adhesive, suitable to make a water-vapour-tight joint between the aluminium foil and the test specimen (see relevant product standard).

NOTE Any combination of foil or sealant and adhesive which provides comparable results can be used.

iTeh STANDARD PREVIEW

6 Test specimens (standards.iteh.ai)

6.1 General

ISO 12629:2011

[https://standards.iteh.ai/catalog/standards/sist/5af57eef-6366-49d4-a35e-](https://standards.iteh.ai/catalog/standards/sist/5af57eef-6366-49d4-a35e-31243276419/iso-12629-2011)

The test specimens shall be representative of the product and shall include any natural surface skins or adhered facings of different materials.

Pipe insulation pieces (half sections or segments) shall be placed together using an appropriate sealant or adhesive to form a full size pipe insulation test specimen.

NOTE For faced or coated products with a water vapour diffusion resistance factor $\mu \leq 3$, for the core material, the permeability can be determined from measurements made on the facing/coating itself, after separation from the product. For pipe insulations with large dimensions, test specimen of the facing or coating can be cut out and tested according to EN 12086.

6.2 Dimensions of the test specimen

Cut the test specimens to a minimum length of (100 ± 1) mm; for outside diameters greater than 100 mm the length shall be at least 150 mm. The cut surfaces shall be as flat as possible, equally formed and perpendicular to the vertical axis of the test specimen.

The thickness of the test specimen shall be the thickness of the product.

6.3 Number of test specimens

The number of test specimens shall be as specified in the relevant product standard. If the number is not specified, then at least five test specimens shall be used.

NOTE In the absence of a product standard or any other European technical specification, the method of selection of the test specimens can be agreed between parties.

6.4 Conditioning of test specimens

The test specimens shall be stored for at least 6 h at $(23 \pm 5) ^\circ\text{C}$. In case of dispute, they shall be stored at $(23 \pm 2) ^\circ\text{C}$ and $(50 \pm 5) \% \text{RH}$ for the time stated in the relevant product standard.

In tropical countries, different conditioning and testing conditions can be relevant. In this case, the conditions shall be $(27 \pm 5) ^\circ\text{C}$ and $(65 \pm 5) \% \text{RH}$, and shall be stated clearly in the test report.

7 Procedure

Bond the test specimen to the aluminium foil (see 5.5), at one end, to achieve a water-vapour-tight joint.

Place sufficient desiccant within the test specimen to maintain “zero” percent RH throughout the test.

The quantity of desiccant shall not be greater than 2/3 of the enclosed volume.

Close the open end of the test specimen as in the first paragraph.

Bubbles under the foil should be avoided, and the bond between the foil and the test specimen should be such that any attempt to separate the foil from the test specimen breaks the test specimen rather than the bond.

In case of products with a low water vapour transmission rate, the borderline between the foil and the test specimen may be sealed in addition with a sealant (e.g. wax) in such a way that the reduction in free surface is not significant.

Immerse the test specimens in the test chamber (see Figure 1) at $(23 \pm 1) ^\circ\text{C}$ and $(50 \pm 3) \% \text{RH}$. Avoid contact between the test specimens.

Condition the test specimens in the test chamber for a period between 1 h and 24 h.

Weigh the test specimens at regular intervals. The weighing shall be carried out under the same conditions that exist in the test chamber. If the weighing is made outside of the chamber, care shall be taken that the duration of time outside of the chamber does not affect the result.

In order to avoid contamination of the test specimen, gloves should be used while handling the test specimen.

Repeat the weighings until five successive determinations of “change in mass per unit time” are constant to within $\pm 5 \%$ of the mean value for the test specimen (see 8.1). Repeat the procedure for the remaining test specimens.

Plot a curve of change in mass against time to help recognize the condition of constant change (steady state).

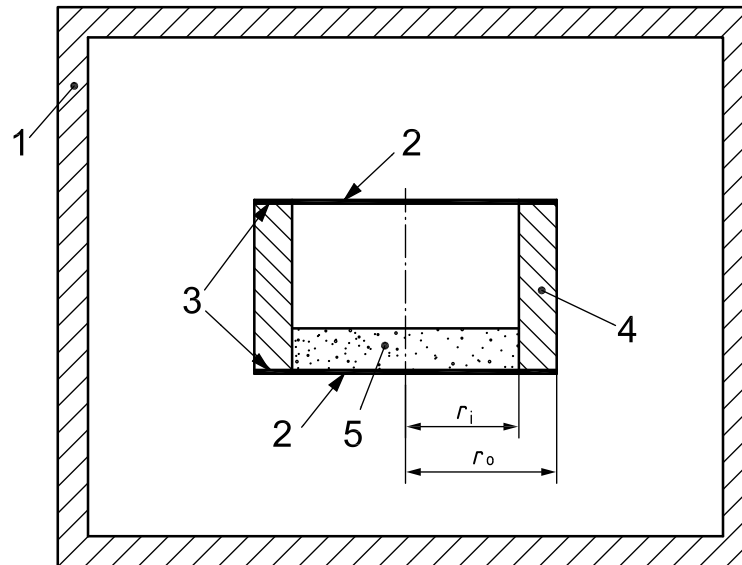
**Key**

- 1 test chamber
 - 2 aluminium foil
 - 3 adhesive
 - 4 test specimen
 - 5 desiccant
- r_i inside radius
 r_o outside radius

iTeh STANDARD PREVIEW
(standards.iteh.ai)

ISO 12629:2011
<https://standards.iteh.ai/catalog/standards/sist/435e-f3134d276dd9/iso-12629-2011>

Figure 1 — Example of test assembly

8 Calculation and expression of results

8.1 Water vapour flow rate

Calculate for each test specimen for the selected time interval, the water vapour flow rate, G_{12} , in milligrams per hour using the equation:

$$G_{12} = \frac{m_2 - m_1}{t_2 - t_1} \quad (1)$$

where

m_1 is the mass of the test assembly at time t_1 , in milligrams;

m_2 is the mass of the test assembly at time t_2 , in milligrams;

t_1 and t_2 are successive times of weighings, in hours.

Calculate G , the mean of five successive determinations of G_{12} , in milligrams per hour, for each test specimen.

The test stops when each of the five successive determinations of G_{12} is within $\pm 5\%$ of G .